

NFPA 70A

National Electrical Code[®]
Requirements for One- and
Two-Family Dwellings

2005 Edition



NFPA, 1 Batterymarch Park, Quincy, MA 02169-7471
An International Codes and Standards Organization

IMPORTANT NOTICES AND DISCLAIMERS CONCERNING NFPA DOCUMENTS

NOTICE AND DISCLAIMER OF LIABILITY CONCERNING THE USE OF NFPA DOCUMENTS

NFPA codes, standards, recommended practices, and guides, of which the document contained herein is one, are developed through a consensus standards development process approved by the American National Standards Institute. This process brings together volunteers representing varied viewpoints and interests to achieve consensus on fire and other safety issues. While the NFPA administers the process and establishes rules to promote fairness in the development of consensus, it does not independently test, evaluate, or verify the accuracy of any information or the soundness of any judgments contained in its codes and standards.

The NFPA disclaims liability for any personal injury, property or other damages of any nature whatsoever, whether special, indirect, consequential or compensatory, directly or indirectly resulting from the publication, use of, or reliance on this document. The NFPA also makes no guaranty or warranty as to the accuracy or completeness of any information published herein.

In issuing and making this document available, the NFPA is not undertaking to render professional or other services for or on behalf of any person or entity. Nor is the NFPA undertaking to perform any duty owed by any person or entity to someone else. Anyone using this document should rely on his or her own independent judgment or, as appropriate, seek the advice of a competent professional in determining the exercise of reasonable care in any given circumstances.

The NFPA has no power, nor does it undertake, to police or enforce compliance with the contents of this document. Nor does the NFPA list, certify, test or inspect products, designs, or installations for compliance with this document. Any certification or other statement of compliance with the requirements of this document shall not be attributable to the NFPA and is solely the responsibility of the certifier or maker of the statement.

ADDITIONAL NOTICES AND DISCLAIMERS

Updating of NFPA Documents

Users of NFPA codes, standards, recommended practices, and guides should be aware that these documents may be superseded at any time by the issuance of new editions or may be amended from time to time through the issuance of Tentative Interim Amendments. An official NFPA document at any point in time consists of the current edition of the document together with any Tentative Interim Amendments and any Errata then in effect. In order to determine whether a given document is the current edition and whether it has been amended through the issuance of Tentative Interim Amendments or corrected through the issuance of Errata, consult appropriate NFPA publications such as the National Fire Codes® Subscription Service, visit the NFPA website at www.nfpa.org, or contact the NFPA at the address listed below.

Interpretations of NFPA Documents

A statement, written or oral, that is not processed in accordance with Section 6 of the Regulations Governing Committee Projects shall not be considered the official position of NFPA or any of its Committees and shall not be considered to be, nor be relied upon as, a Formal Interpretation.

Patents

The NFPA does not take any position with respect to the validity of any patent rights asserted in connection with any items which are mentioned in or are the subject of NFPA codes, standards, recommended practices, and guides, and the NFPA disclaims liability for the infringement of any patent resulting from the use of or reliance on these documents. Users of these documents are expressly advised that determination of the validity of any such patent rights, and the risk of infringement of such rights, is entirely their own responsibility.

NFPA adheres to applicable policies of the American National Standards Institute with respect to patents. For further information contact the NFPA at the address listed below.

Law and Regulations

Users of these documents should consult applicable federal, state, and local laws and regulations. NFPA does not, by the publication of its codes, standards, recommended practices, and guides, intend to urge action that is not in compliance with applicable laws, and these documents may not be construed as doing so.

Copyrights

This document is copyrighted by the NFPA. It is made available for a wide variety of both public and private uses. These include both use, by reference, in laws and regulations, and use in private self-regulation, standardization, and the promotion of safe practices and methods. By making this document available for use and adoption by public authorities and private users, the NFPA does not waive any rights in copyright to this document.

Use of NFPA documents for regulatory purposes should be accomplished through adoption by reference. The term "adoption by reference" means the citing of title, edition, and publishing information only. Any deletions, additions, and changes desired by the adopting authority should be noted separately in the adopting instrument. In order to assist NFPA in following the uses made of its documents, adopting authorities are requested to notify the NFPA (Attention: Secretary, Standards Council) in writing of such use. For technical assistance and questions concerning adoption of NFPA documents, contact NFPA at the address below.

For Further Information

All questions or other communications relating to NFPA codes, standards, recommended practices, and guides and all requests for information on NFPA procedures governing its codes and standards development process, including information on the procedures for requesting Formal Interpretations, for proposing Tentative Interim Amendments, and for proposing revisions to NFPA documents during regular revision cycles, should be sent to NFPA headquarters, addressed to the attention of the Secretary, Standards Council, NFPA, 1 Batterymarch Park, P.O. Box 9101, Quincy, MA 02269-9101.

For more information about NFPA, visit the NFPA website at www.nfpa.org.

Copyright © 2005 NFPA, All Rights Reserved

NFPA 70A

National Electrical Code® Requirements for One- and Two-Family Dwellings

2005 Edition

Excerpted from the 2005 *National Electrical Code*® NFPA 70–2005

Preface

This 2005 edition of NFPA 70A is a compilation of electrical provisions for one- and two-family dwellings. The provisions assembled in this compilation have been extracted directly from the 2005 edition of NFPA 70, *National Electrical Code*® (*NEC*®), and have been editorially revised only where necessary to limit their application to one- and two-family dwellings. This compilation has been reviewed and approved by the National Electrical Code Committee through its Technical Correlating Committee. It is being provided for the convenience of inspectors, contractors, builders, and others who are primarily interested in only those *NEC* rules that apply to one- and two-family dwellings.

Only those wiring methods and materials commonly encountered in new construction at one- and two-family dwellings are included in NFPA 70A. In like manner, only current ratings up to and including 400 amperes (based on Table 310.15(B)(6)) and voltages up to and including 600 volts are covered in NFPA 70A. It is the intent that the rules covering wiring methods, any materials, or any type of equipment, such as motors, not specifically included in this document are to be covered by the applicable rules in the 2005 edition of the *National Electrical Code*.

Where a reference is made to an article or section not included in NFPA 70A, such as to Article 430 or 430.52, the reference is to that article or section as it appears in the 2005 edition of the *National Electrical Code*.

The numbering system for articles and sections of the 2005 edition of the *National Electrical Code* has been preserved in NFPA 70A, so that provisions in NFPA 70A bear the same numerical designation as they have in the *NEC*. The user of NFPA 70A should be aware, therefore, that there are gaps in the numerical sequence of provisions in NFPA 70A, and that these gaps are a natural consequence of the fact that NFPA 70A contains only selected provisions of the *NEC*.

This edition of NFPA 70A has been reviewed by the *NEC* Technical Correlating Committee, and the committee has determined, by way of an affirmative letter ballot, that the extracting and editorial revision of *NEC* text included in NFPA 70A has been achieved without altering the technical intent of the 2005 edition of the *National Electrical Code*.

As the 2005 edition of the *National Electrical Code* is the parent document for the extracted text contained in NFPA 70A, any request for a formal interpretation of any text in NFPA 70A will be processed in accordance with the NFPA Regulations Governing Committee Projects as a formal interpretation of the 2005 edition of the *National Electrical Code*.

Prior to this 2005 edition, the most recent previous edition of NFPA 70A was the 2002 edition.

NATIONAL ELECTRICAL CODE COMMITTEE

This list represents the membership at the time the Technical Correlating Committee was balloted on the final text of this edition. Since that time, changes in the membership may have occurred. A key to classifications is found at the back of this book.

Technical Correlating Committee

James W. Carpenter, *Chair* [E]

International Association of Electrical Inspectors, TX
Rep. International Association of Electrical Inspectors

Mark W. Earley, *Secretary*

National Fire Protection Association, MA
(nonvoting)

Jean A. O'Connor, *Recording Secretary*

National Fire Protection Association, MA
(nonvoting)

James E. Brunssen, Telcordia, NJ [UT]

Rep. Alliance for Telecommunications Industry Solutions

Michael I. Callanan, National Joint Apprentice & Training
Committee, MD [L]

Rep. International Brotherhood of Electrical Workers

William R. Drake, Marinco, CA [M]

John R. Kovacik, Underwriters Laboratories Incorporated, IL
[RT]

William M. Lewis, Eli Lilly & Company, IN [U]

Rep. American Chemistry Council

James T. Pauley, Square D Company, KY [M]

Rep. National Electrical Manufacturers Association

Michael D. Toman, MEGA Power Electrical Services,
Incorporated, MD [IM]

Rep. National Electrical Contractors Association

John W. Troglia, Edison Electric Institute, WI [UT]

Rep. Electric Light & Power Group/EEI

Alternates

Jeffrey Boksiner, Telcordia Technologies, Incorporated, NJ
[UT]

Rep. Alliance for Telecommunications Industry Solutions
(Alt. to J. E. Brunssen)

Philip H. Cox, Bigelow, AR [E]

Rep. International Association of Electrical Inspectors
(Alt. To J. W. Carpenter)

James M. Daly, General Cable, NJ [M]

Rep. National Electrical Manufacturers Association
(Alt. to J. T. Pauley)

Stanley J. Folz, Folz Electric, Incorporated, IL [IM]

Rep. National Electrical Contractors Association
(Alt. to M. D. Toman)

Palmer L. Hickman, National Joint Apprentice & Training
Committee, MD [L]

Rep. International Brotherhood of Electrical Workers
(Alt. to M. I. Callanan)

Neil F. LaBrake, Jr., Niagara Mohawk, a National Grid
Company, NY [UT]

Rep. Electric Light & Power Group/EEI
(Alt. to J. W. Troglia)

Danny P. Liggett, DuPont Co., TX [U]

Rep. American Chemistry Council
(Alt. to W. M. Lewis)

Mark C. Ode, Underwriters Laboratories, Incorporated, NC
[RT]

(Alt. to J. R. Kovacik)

Nonvoting

Richard G. Biermann, Biermann Electric Company,
Incorporated, IA [IM]

(Member Emeritus)

D. Harold Ware, Libra Electric Company, OK [IM]

(Member Emeritus)

Contents

<p>ARTICLE</p> <p>90 Introduction 70A–1</p> <p style="text-align: center;">Chapter 1 General</p> <p>100 Definitions 70A–5</p> <p style="padding-left: 20px;">I. General 70A–5</p> <p>110 Requirements for Electrical Installations 70A–10</p> <p style="padding-left: 20px;">I. General 70A–10</p> <p style="padding-left: 20px;">II. 600 Volts, Nominal, or Less. 70A–13</p> <p style="text-align: center;">Chapter 2 Wiring and Protection</p> <p>200 Use and Identification of Grounded Conductors 70A–15</p> <p>210 Branch Circuits 70A–16</p> <p style="padding-left: 20px;">I. General Provisions 70A–16</p> <p style="padding-left: 20px;">II. Branch-Circuit Ratings 70A–19</p> <p style="padding-left: 20px;">III. Required Outlets 70A–21</p> <p>215 Feeders 70A–25</p> <p>220 Branch-Circuit, Feeder, and Service Calculations 70A–26</p> <p style="padding-left: 20px;">I. General 70A–26</p> <p style="padding-left: 20px;">II. Branch Circuit Load Calculations 70A–26</p> <p style="padding-left: 20px;">III. Feeder and Service Load Calculations 70A–27</p> <p>225 Outside Branch Circuits and Feeders 70A–30</p> <p style="padding-left: 20px;">I. General 70A–31</p> <p style="padding-left: 20px;">II. More Than One Building or Other Structure 70A–33</p> <p>230 Services 70A–34</p> <p style="padding-left: 20px;">I. General 70A–34</p> <p style="padding-left: 20px;">II. Overhead Service-Drop Conductors 70A–35</p> <p style="padding-left: 20px;">III. Underground Service-Lateral Conductors 70A–36</p> <p style="padding-left: 20px;">IV. Service-Entrance Conductors 70A–37</p> <p style="padding-left: 20px;">V. Service Equipment—General 70A–39</p> <p style="padding-left: 20px;">VI. Service Equipment—Disconnecting Means 70A–39</p> <p style="padding-left: 20px;">VII. Service Equipment—Overcurrent Protection 70A–40</p> <p>240 Overcurrent Protection 70A–41</p> <p style="padding-left: 20px;">I. General 70A–41</p> <p style="padding-left: 20px;">II. Location 70A–42</p> <p style="padding-left: 20px;">III. Enclosures 70A–43</p> <p style="padding-left: 20px;">V. Plug Fuses, Fuseholders, and Adapters 70A–43</p> <p>250 Grounding and Bonding 70A–43</p> <p style="padding-left: 20px;">I. General 70A–43</p> <p style="padding-left: 20px;">II. System Grounding 70A–45</p> <p style="padding-left: 20px;">III. Grounding Electrode System and Grounding Electrode Conductor 70A–47</p>	<p>ARTICLE</p> <p>IV. Enclosure, Raceway, and Service Cable Grounding 70A–51</p> <p>V. Bonding 70A–52</p> <p>VI. Equipment Grounding and Equipment Grounding Conductors 70A–54</p> <p>VII. Methods of Equipment Grounding 70A–57</p> <p>280 Surge Arresters 70A–59</p> <p>285 Transient Voltage Surge Suppressors: TVSSs 70A–59</p> <p style="padding-left: 20px;">I. General 70A–59</p> <p style="padding-left: 20px;">II. Installation 70A–59</p> <p style="padding-left: 20px;">III. Connecting Transient Voltage Surge Suppressors 70A–59</p> <p style="text-align: center;">Chapter 3 Wiring Methods and Materials</p> <p>300 Wiring Methods 70A–61</p> <p style="padding-left: 20px;">I. General Requirements 70A–61</p> <p>310 Conductors for General Wiring 70A–68</p> <p>312 Cabinets, Cutout Boxes, and Meter Socket Enclosures 70A–73</p> <p style="padding-left: 20px;">I. Installation 70A–73</p> <p>314 Outlet, Device, Pull, and Junction Boxes; Conduit Bodies; Fittings; and Handhole Enclosures 70A–76</p> <p style="padding-left: 20px;">I. Scope and General 70A–76</p> <p style="padding-left: 20px;">II. Installation 70A–76</p> <p>320 Armored Cable: Type AC 70A–82</p> <p style="padding-left: 20px;">I. General 70A–82</p> <p style="padding-left: 20px;">II. Installation 70A–82</p> <p>330 Metal-Clad Cable: Type MC 70A–83</p> <p style="padding-left: 20px;">I. General 70A–83</p> <p style="padding-left: 20px;">II. Installation 70A–83</p> <p>334 Nonmetallic-Sheathed Cable: Types NM and NMC 70A–84</p> <p style="padding-left: 20px;">I. General 70A–84</p> <p style="padding-left: 20px;">II. Installation 70A–84</p> <p>338 Service-Entrance Cable: Types SE and USE 70A–86</p> <p style="padding-left: 20px;">I. General 70A–86</p> <p style="padding-left: 20px;">II. Installation 70A–86</p> <p>340 Underground Feeder and Branch-Circuit Cable: Type UF 70A–87</p> <p style="padding-left: 20px;">I. General 70A–87</p> <p style="padding-left: 20px;">II. Installation 70A–87</p> <p>342 Intermediate Metal Conduit: Type IMC 70A–87</p> <p style="padding-left: 20px;">I. General 70A–87</p> <p style="padding-left: 20px;">II. Installation 70A–88</p> <p>344 Rigid Metal Conduit: Type RMC 70A–89</p> <p style="padding-left: 20px;">I. General 70A–89</p> <p style="padding-left: 20px;">II. Installation 70A–89</p>
---	--

ARTICLE

348	Flexible Metal Conduit: Type FMC	70A–90
	I. General	70A–90
	II. Installation	70A–91
350	Liquidtight Flexible Metal Conduit: Type LFMC	70A–92
	I. General	70A–92
	II. Installation	70A–92
352	Rigid Nonmetallic Conduit: Type RNC	70A–93
	I. General	70A–93
	II. Installation	70A–93
356	Liquidtight Flexible Nonmetallic Conduit: Type LFNC	70A–95
	I. General	70A–95
	II. Installation	70A–96
358	Electrical Metallic Tubing: Type EMT	70A–97
	I. General	70A–97
	II. Installation	70A–97
362	Electrical Nonmetallic Tubing: Type ENT	70A–99
	I. General	70A–99
	II. Installation	70A–99
380	Multioutlet Assembly	70A–100

Chapter 4 Equipment for General Use

400	Flexible Cords and Cables	70A–101
	I. General	70A–101
404	Switches	70A–101
	I. Installation	70A–101
406	Receptacles, Cord Connectors, and Attachment Plugs (Caps)	70A–103
408	Switchboards and Panelboards	70A–105
	I. General	70A–105
	III. Panelboards	70A–106
410	Luminaires (Lighting Fixtures), Lampholders, and Lamps	70A–107
	I. General	70A–107
	II. Luminaire (Fixture) Locations	70A–107
	III. Provisions at Luminaire (Fixture) Outlet Boxes, Canopies, and Pans	70A–108
	IV. Luminaire (Fixture) Supports	70A–109
	V. Grounding	70A–109
	VI. Wiring of Luminaires (Fixtures)	70A–110
VIII.	Installation of Lampholders	70A–111
	XI. Special Provisions for Flush and Recessed Luminaires (Fixtures)	70A–111
XIII.	Special Provisions for Electric-Discharge Lighting Systems of 1000 Volts or Less	70A–111
XIV.	Special Provisions for Electric-Discharge Lighting Systems of More Than 1000 Volts	70A–112
XV.	Lighting Track	70A–112

ARTICLE

411	Lighting Systems Operating at 30 Volts or Less	70A–113
422	Appliances	70A–113
	I. General	70A–113
	II. Installation	70A–114
	III. Disconnecting Means	70A–116
	V. Marking	70A–116
424	Fixed Electric Space-Heating Equipment	70A–117
	I. General	70A–117
	II. Installation	70A–117
	III. Control and Protection of Fixed Electric Space-Heating Equipment	70A–118
	IV. Marking of Heating Equipment	70A–119
	V. Electric Space-Heating Cables	70A–120
	VI. Duct Heaters	70A–121
	VII. Resistance-Type Boilers	70A–122
	IX. Electric Radiant Heating Panels and Heating Panel Sets	70A–122
440	Air-Conditioning and Refrigerating Equipment	70A–124
	I. General	70A–124
	II. Disconnecting Means	70A–125
	III. Branch-Circuit Short-Circuit and Ground-Fault Protection	70A–126
	IV. Branch-Circuit Conductors	70A–127
	V. Controllers for Motor-Compressors	70A–127
	VI. Motor-Compressor and Branch-Circuit Overload Protection	70A–128
	VII. Provisions for Room Air Conditioners	70A–129
445	Generators	70A–129

Chapter 5 Special Occupancies

550	Mobile Homes, Manufactured Homes, and Mobile Home Parks	70A–131
	I. General	70A–131
	III. Services and Feeders	70A–131
590	Temporary Installations	70A–133

Chapter 6 Special Equipment

680	Swimming Pools, Fountains, and Similar Installations	70A–137
	I. General	70A–137
	II. Permanently Installed Pools	70A–139
	III. Storable Pools	70A–146
	IV. Spas and Hot Tubs	70A–147
	VII. Hydromassage Bathtubs	70A–148
690	Solar Photovoltaic Systems	70A–149
692	Fuel Cell Systems	70A–149

ARTICLE

Chapter 7 Special Conditions

702 Optional Standby Systems 70A–151
 I. General 70A–151
 II. Circuit Wiring 70A–151
 III. Grounding 70A–151

725 Class 1, Class 2, and Class 3 Remote-Control, Signaling, and Power-Limited Circuits 70A–152
 I. General 70A–152
 II. Class 1 Circuits 70A–153
 III. Class 2 and Class 3 Circuits 70A–153

760 Fire Alarm Systems 70A–155
 I. General 70A–155
 II. Non-Power-Limited Fire Alarm (NPLFA) Circuits 70A–156
 III. Power-Limited Fire Alarm (PLFA) Circuits 70A–156

Chapter 8 Communications Systems

800 Communications Circuits 70A–159
 I. General 70A–159
 II. Wires and Cables Outside and Entering Buildings 70A–159
 III. Protection 70A–160
 IV. Grounding Methods 70A–160
 V. Communications Wires and Cables Within Buildings 70A–161

820 Community Antenna Television and Radio Distribution Systems 70A–163
 I. General 70A–163

ARTICLE

II. Cables Outside and Entering Buildings . . . 70A–163
 III. Protection 70A–164
 IV. Grounding Methods 70A–164
 V. Cables Within Buildings 70A–165

830 Network-Powered Broadband Communications Systems 70A–167
 I. General 70A–167
 II. Cables Outside and Entering Buildings . . . 70A–168
 III. Protection 70A–169
 IV. Grounding Methods 70A–170
 V. Wiring Methods Within Buildings 70A–172

Chapter 9 Tables

TABLE

1 Percent of Cross Section of Conduit and Tubing for Conductors 70A–175
 2 Radius of Conduit and Tubing Bends 70A–175
 4 Dimensions and Percent Area of Conduit and Tubing (Areas of Conduit or Tubing for the Combinations of Wires Permitted in Table 1, Chapter 9) 70A–176
 5 Dimensions of Insulated Conductors 70A–180
 5A Compact Aluminum Building Wire Nominal Dimensions and Areas 70A–181
 8 Conductor Properties 70A–182

Annex C 70A–183
Annex D 70A–195
Index 70A–205

NFPA 70A

**National Electrical Code® Requirements
for One- and Two-Family Dwellings****2005 Edition**

IMPORTANT NOTE: This NFPA document is made available for use subject to important notices and legal disclaimers. These notices and disclaimers appear in all publications containing this document and may be found under the heading “Important Notices and Disclaimers Concerning NFPA Documents.” They can also be obtained on request from NFPA or viewed at www.nfpa.org/disclaimers.

Throughout this document the term “this Code” refers to the compilation of requirements for electrical installations in one- and two-family dwelling units contained therein that have been extracted from NFPA 70-2005, National Electrical Code® (NEC®).

ARTICLE 90 Introduction
--

90.1 Purpose.

(A) Practical Safeguarding. The purpose of the NEC is the practical safeguarding of persons and property from hazards arising from the use of electricity.

(B) Adequacy. This Code contains provisions that are considered necessary for safety. Compliance therewith and proper maintenance results in an installation that is essentially free from hazard but not necessarily efficient, convenient, or adequate for good service or future expansion of electrical use.

FPN: Hazards often occur because of overloading of wiring systems by methods or usage not in conformity with this Code. This occurs because initial wiring did not provide for increases in the use of electricity. An initial adequate installation and reasonable provisions for system changes provide for future increases in the use of electricity.

(C) Intention. This Code is not intended as a design specification or an instruction manual for untrained persons.

(D) Relation to Other International Standards. The requirements in this Code address the fundamental principles of protection for safety contained in Section 131 of International Electrotechnical Commission Standard 60364-1, Electrical Installations of Buildings.

FPN: IEC 60364-1, Section 131, contains fundamental principles of protection for safety that encompass protection against electric shock, protection against thermal effects,

protection against overcurrent, protection against fault currents, and protection against overvoltage. All of these potential hazards are addressed by the requirements in this Code.

90.2 Scope.

(A) Covered. This Code covers only those wiring methods and materials most commonly encountered in new construction at one- and two-family dwellings.

(B) Not Covered.

- (1) This Code does not contain all of the rules necessary to cover mobile homes and manufactured homes, recreational vehicles, park trailers, floating dwelling units, buildings containing more than two dwelling units or buildings used for other than dwelling purposes. For those installations, the 2005 National Electrical Code (NFPA 70-2005) shall apply.
- (5) This Code does not cover installations under the exclusive control of an electric utility where such installations
 - a. Consist of service drops or service laterals, and associated metering, or
 - b. Are located in legally established easements, rights-of-way, or by other agreements either designated by or recognized by public service commissions, utility commissions, or other regulatory agencies having jurisdiction for such installations, or
 - c. Are on property owned or leased by the electric utility for the purpose of communications, metering, generation, control, transformation, transmission, or distribution of electric energy.

FPN to (5): Examples of utilities may include those entities that are typically designated or recognized by governmental law or regulation by public service/utility commissions and that install, operate, and maintain electric supply (such as generation, transmission, or distribution systems) or communication systems (such as telephone, CATV, Internet, satellite, or data services). Utilities may be subject to compliance with codes and standards covering their regulated activities as adopted under governmental law or regulation. Additional information can be found through consultation with the appropriate governmental bodies, such as state regulatory commissions, Federal Energy Regulatory Commission, and Federal Communications Commission.

(C) Special Permission. The authority having jurisdiction for enforcing this Code may grant exception for the installation of conductors and equipment that are not under the exclusive control of the electric utilities and are used to connect the electric utility supply system to the service-entrance conductors of the premises served, provided such installations are outside a building or terminate immediately inside a building wall.

90.3 Code Arrangement. This Code is divided into the introduction and nine chapters, as shown in Figure 90.3.

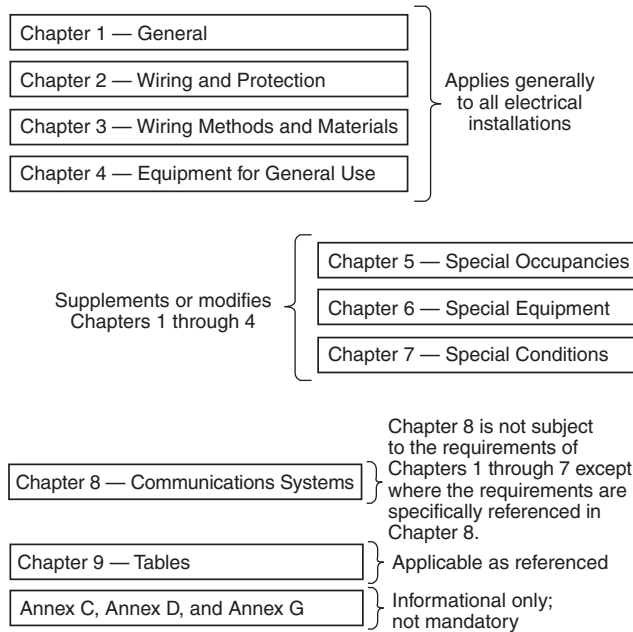

Figure 90.3 Code Arrangement.

Chapters 1, 2, 3, and 4 apply generally; Chapters 5, 6, and 7 apply to special occupancies, special equipment, or other special conditions. These latter chapters supplement or modify the general rules. Chapters 1 through 4 apply except as amended by Chapters 5, 6, and 7 for the particular conditions.

Chapter 8 covers communications systems and is not subject to the requirements of Chapters 1 through 7 except where the requirements are specifically referenced in Chapter 8.

Chapter 9 consists of tables.

Annexes are not part of the requirements of this *Code* but are included for informational purposes only.

90.4 Enforcement. This *Code* is intended to be suitable for mandatory application by governmental bodies that exercise legal jurisdiction over electrical installations, including signaling and communications systems, and for use by insurance inspectors. The authority having jurisdiction for enforcement of the *Code* has the responsibility for making interpretations of the rules, for deciding on the approval of equipment and materials, and for granting the special permission contemplated in a number of the rules.

By special permission, the authority having jurisdiction may waive specific requirements in this *Code* or permit alternative methods where it is assured that equivalent objectives can be achieved by establishing and maintaining effective safety.

This *Code* may require new products, constructions, or materials that may not yet be available at the time the *Code* is adopted. In such event, the authority having jurisdiction may permit the use of the products, constructions, or materi-

als that comply with the most recent previous edition of this *Code* adopted by the jurisdiction.

90.5 Mandatory Rules, Permissive Rules, and Explanatory Material.

(A) Mandatory Rules. Mandatory rules of this *Code* are those that identify actions that are specifically required or prohibited and are characterized by the use of the terms *shall* or *shall not*.

(B) Permissive Rules. Permissive rules of this *Code* are those that identify actions that are allowed but not required, are normally used to describe options or alternative methods, and are characterized by the use of the terms *shall be permitted* or *shall not be required*.

(C) Explanatory Material. Explanatory material, such as references to other standards, references to related sections of this *Code*, or information related to a *Code* rule, is included in this *Code* in the form of fine print notes (FPNs). Fine print notes are informational only and are not enforceable as requirements of this *Code*.

Brackets containing section references to another NFPA document are for informational purposes only and are provided as a guide to indicate the source of the extracted text. These bracketed references immediately follow the extracted text.

FPN: The format and language used in this *Code* follows guidelines established by NFPA and published in the *NEC Style Manual*. Copies of this manual can be obtained from NFPA.

(D) Application of the NEC. It is recognized that there may be portions of an installation in a one- or two-family dwelling that are not covered by this *Code*. In those installations, the requirements of the 2005 *National Electrical Code* (NFPA 70-2005) shall apply. If there is a technical difference between the requirements of this *Code* and the requirements contained in the 2005 *National Electrical Code* (NFPA 70-2005), the requirements of NFPA 70-2005 shall apply.

Other wiring methods, materials, and subject matter covered in the 2005 *National Electrical Code* (NFPA 70-2005) are also recognized by this *Code*.

90.6 Formal Interpretations. To promote uniformity of interpretation and application of the provisions of this *Code*, formal interpretation procedures have been established and are found in the NFPA Regulations Governing Committee Projects. The technical requirements of this *Code* are extracted from the 2005 *National Electrical Code* (NFPA 70-2005). Requests for formal interpretations of this *Code* shall be processed based on the requirements contained in the 2005 *National Electrical Code* (NFPA 70-2005).

90.7 Examination of Equipment for Safety. For specific items of equipment and materials referred to in this *Code*, examinations for safety made under standard conditions provide a basis for approval where the record is made generally available through promulgation by organizations properly equipped and qualified for experimental testing, inspections of the run of goods at factories, and service-value determination through field inspections. This avoids the necessity for repetition of examinations by different examiners, frequently with inadequate facilities for such work, and the confusion that would result from conflicting reports on the suitability of devices and materials examined for a given purpose.

It is the intent of this *Code* that factory-installed internal wiring or the construction of equipment need not be inspected at the time of installation of the equipment, except to detect alterations or damage, if the equipment has been listed by a qualified electrical testing laboratory that is recognized as having the facilities described in the preceding paragraph and that requires suitability for installation in accordance with this *Code*.

FPN No. 1: See requirements in 110.3.

FPN No. 2: *Listed* is defined in Article 100.

FPN No. 3: Annex A in the *NEC* contains an informative list of product safety standards for electrical equipment.

90.8 Wiring Planning.

(A) Future Expansion and Convenience. Plans and specifications that provide ample space in raceways, spare raceways, and additional spaces allow for future increases in electric power and communication circuits. Distribution centers located in readily accessible locations provide convenience and safety of operation.

(B) Number of Circuits in Enclosures. It is elsewhere provided in this *Code* that the number of wires and circuits confined in a single enclosure be varyingly restricted. Limiting the number of circuits in a single enclosure minimizes the effects from a short circuit or ground fault in one circuit.

90.9 Units of Measurement.

(A) Measurement System of Preference. For the purpose of this *Code*, metric units of measurement are in accordance

with the modernized metric system known as the International System of Units (SI).

(B) Dual System of Units. SI units shall appear first, and inch-pound units shall immediately follow in parentheses. Conversion from inch-pound units to SI units shall be based on hard conversion except as provided in 90.9(C).

(C) Permitted Uses of Soft Conversion. The cases given in 90.9(C)(1) through (C)(4) shall not be required to use hard conversion and shall be permitted to use soft conversion.

(1) Trade Sizes. Where the actual measured size of a product is not the same as the nominal size, trade size designators shall be used rather than dimensions. Trade practices shall be followed in all cases.

(2) Extracted Material. Where material is extracted from another standard, the context of the original material shall not be compromised or violated. Any editing of the extracted text shall be confined to making the style consistent with that of the *NEC*.

(3) Industry Practice. Where industry practice is to express units in inch-pound units, the inclusion of SI units shall not be required.

(4) Safety. Where a negative impact on safety would result, soft conversion shall be used.

(D) Compliance. Conversion from inch-pound units to SI units shall be permitted to be an approximate conversion. Compliance with the numbers shown in either the SI system or the inch-pound system shall constitute compliance with this *Code*.

FPN No. 1: Hard conversion is considered a change in dimensions or properties of an item into new sizes that might or might not be interchangeable with the sizes used in the original measurement. Soft conversion is considered a direct mathematical conversion and involves a change in the description of an existing measurement but not in the actual dimension.

FPN No. 2: SI conversions are based on IEEE/ASTM SI 10-1997, *Standard for the Use of the International System of Units (SI): The Modern Metric System*.

Chapter 1 General

ARTICLE 100 Definitions

Scope. This article contains only those definitions essential to the proper application of this *Code*. It is not intended to include commonly defined general terms or commonly defined technical terms from related codes and standards. In general, only those terms that are used in two or more articles are defined in Article 100. Other definitions are included in the article in which they are used but may be referenced in Article 100.

I. General

Accessible (as applied to equipment). Admitting close approach; not guarded by locked doors, elevation, or other effective means.

Accessible (as applied to wiring methods). Capable of being removed or exposed without damaging the building structure or finish or not permanently closed in by the structure or finish of the building.

Accessible, Readily (Readily Accessible). Capable of being reached quickly for operation, renewal, or inspections without requiring those to whom ready access is requisite to climb over or remove obstacles or to resort to portable ladders, and so forth.

Ampacity. The current, in amperes, that a conductor can carry continuously under the conditions of use without exceeding its temperature rating.

Appliance. Utilization equipment, generally other than industrial, that is normally built in standardized sizes or types and is installed or connected as a unit to perform one or more functions such as clothes washing, air conditioning, food mixing, deep frying, and so forth.

Approved. Acceptable to the authority having jurisdiction.

Attachment Plug (Plug Cap) (Plug). A device that, by insertion in a receptacle, establishes a connection between the conductors of the attached flexible cord and the conductors connected permanently to the receptacle.

Authority Having Jurisdiction (AHJ). The organization, office, or individual responsible for approving equipment, materials, an installation, or a procedure.

FPN: The phrase “authority having jurisdiction” is used in NFPA documents in a broad manner, since jurisdictions and

approval agencies vary, as do their responsibilities. Where public safety is primary, the AHJ may be a federal, state, local, or other regional department or individual such as a fire chief; fire marshal; chief of a fire prevention bureau, labor department, or health department; building official; electrical inspector; or others having statutory authority. For insurance purposes, an insurance inspection department, rating bureau, or other insurance company representative may be the AHJ. In many circumstances, the property owner or his or her designated agent assumes the role of the AHJ; at government installations, the commanding officer or departmental official may be the AHJ.

Automatic. Self-acting, operating by its own mechanism when actuated by some impersonal influence, as, for example, a change in current, pressure, temperature, or mechanical configuration.

Bathroom. An area including a basin with one or more of the following: a toilet, a tub, or a shower.

Bonding (Bonded). The permanent joining of metallic parts to form an electrically conductive path that ensures electrical continuity and the capacity to conduct safely any current likely to be imposed.

Bonding Jumper. A reliable conductor to ensure the required electrical conductivity between metal parts required to be electrically connected.

Bonding Jumper, Equipment. The connection between two or more portions of the equipment grounding conductor.

Bonding Jumper, Main. The connection between the grounded circuit conductor and the equipment grounding conductor at the service.

Branch Circuit. The circuit conductors between the final overcurrent device protecting the circuit and the outlet(s).

Branch Circuit, Appliance. A branch circuit that supplies energy to one or more outlets to which appliances are to be connected and that has no permanently connected luminaires (lighting fixtures) that are not a part of an appliance.

Branch Circuit, General-Purpose. A branch circuit that supplies two or more receptacles or outlets for lighting and appliances.

Branch Circuit, Individual. A branch circuit that supplies only one utilization equipment.

Branch Circuit, Multiwire. A branch circuit that consists of two or more ungrounded conductors that have a voltage between them, and a grounded conductor that has equal voltage between it and each ungrounded conductor of the circuit and that is connected to the neutral or grounded conductor of the system.

Building. A structure that stands alone or that is cut off from adjoining structures by fire walls with all openings therein protected by approved fire doors.

Cabinet. An enclosure that is designed for either surface mounting or flush mounting and is provided with a frame, mat, or trim in which a swinging door or doors are or can be hung.

Circuit Breaker. A device designed to open and close a circuit by nonautomatic means and to open the circuit automatically on a predetermined overcurrent without damage to itself when properly applied within its rating.

FPN: The automatic opening means can be integral, direct acting with the circuit breaker, or remote from the circuit breaker.

Adjustable (as applied to circuit breakers). A qualifying term indicating that the circuit breaker can be set to trip at various values of current, time, or both, within a predetermined range.

Instantaneous Trip (as applied to circuit breakers). A qualifying term indicating that no delay is purposely introduced in the tripping action of the circuit breaker.

Inverse Time (as applied to circuit breakers). A qualifying term indicating that there is purposely introduced a delay in the tripping action of the circuit breaker, which delay decreases as the magnitude of the current increases.

Nonadjustable (as applied to circuit breakers). A qualifying term indicating that the circuit breaker does not have any adjustment to alter the value of current at which it will trip or the time required for its operation.

Setting (of circuit breakers). The value of current, time, or both, at which an adjustable circuit breaker is set to trip.

Concealed. Rendered inaccessible by the structure or finish of the building. Wires in concealed raceways are considered concealed, even though they may become accessible by withdrawing them.

Conductor, Bare. A conductor having no covering or electrical insulation whatsoever.

Conductor, Covered. A conductor encased within material of composition or thickness that is not recognized by this Code as electrical insulation.

Conductor, Insulated. A conductor encased within material of composition and thickness that is recognized by this Code as electrical insulation.

Conduit Body. A separate portion of a conduit or tubing system that provides access through a removable cover(s) to the interior of the system at a junction of two or more sections of the system or at a terminal point of the system.

Boxes such as FS and FD or larger cast or sheet metal boxes are not classified as conduit bodies.

Connector, Pressure (Solderless). A device that establishes a connection between two or more conductors or between one or more conductors and a terminal by means of mechanical pressure and without the use of solder.

Continuous Load. A load where the maximum current is expected to continue for 3 hours or more.

Cooking Unit, Counter-Mounted. A cooking appliance designed for mounting in or on a counter and consisting of one or more heating elements, internal wiring, and built-in or mountable controls.

Copper-Clad Aluminum Conductors. Conductors drawn from a copper-clad aluminum rod with the copper metallurgically bonded to an aluminum core. The copper forms a minimum of 10 percent of the cross-sectional area of a solid conductor or each strand of a stranded conductor.

Cutout Box. An enclosure designed for surface mounting that has swinging doors or covers secured directly to and telescoping with the walls of the box proper.

Dead Front. Without live parts exposed to a person on the operating side of the equipment.

Demand Factor. The ratio of the maximum demand of a system, or part of a system, to the total connected load of a system or the part of the system under consideration.

Device. A unit of an electrical system that is intended to carry or control but not utilize electric energy.

Disconnecting Means. A device, or group of devices, or other means by which the conductors of a circuit can be disconnected from their source of supply.

Dusttight. Constructed so that dust will not enter the enclosing case under specified test conditions.

Duty, Continuous. Operation at a substantially constant load for an indefinitely long time.

Duty, Intermittent. Operation for alternate intervals of (1) load and no load; or (2) load and rest; or (3) load, no load, and rest.

Duty, Periodic. Intermittent operation in which the load conditions are regularly recurrent.

Duty, Short-Time. Operation at a substantially constant load for a short and definite, specified time.

Duty, Varying. Operation at loads, and for intervals of time, both of which may be subject to wide variation.

Dwelling Unit. A single unit, providing complete and independent living facilities for one or more persons, including

permanent provisions for living, sleeping, cooking, and sanitation.

Dwelling, One-Family. A building that consists solely of one dwelling unit.

Dwelling, Two-Family. A building that consists solely of two dwelling units.

Dwelling, Multifamily. A building that contains three or more dwelling units.

Electric Sign. A fixed, stationary, or portable self-contained, electrically illuminated utilization equipment with words or symbols designed to convey information or attract attention.

Enclosed. Surrounded by a case, housing, fence, or wall(s) that prevents persons from accidentally contacting energized parts.

Enclosure. The case or housing of apparatus, or the fence or walls surrounding an installation to prevent personnel from accidentally contacting energized parts or to protect the equipment from physical damage.

FPN: See Table 430.91 in the *NEC* for examples of enclosure types.

Energized. Electrically connected to, or is, a source of voltage.

Equipment. A general term including material, fittings, devices, appliances, luminaires (fixtures), apparatus, and the like used as a part of, or in connection with, an electrical installation.

Exposed (as applied to live parts). Capable of being inadvertently touched or approached nearer than a safe distance by a person. It is applied to parts that are not suitably guarded, isolated, or insulated.

Exposed (as applied to wiring methods). On or attached to the surface or behind panels designed to allow access.

Externally Operable. Capable of being operated without exposing the operator to contact with live parts.

Feeder. All circuit conductors between the service equipment, the source of a separately derived system, or other power supply source and the final branch-circuit overcurrent device.

Festoon Lighting. A string of outdoor lights that is suspended between two points.

Fitting. An accessory such as a locknut, bushing, or other part of a wiring system that is intended primarily to perform a mechanical rather than an electrical function.

Garage. A building or portion of a building in which one or more self-propelled vehicles can be kept for use, sale, storage, rental, repair, exhibition, or demonstration purposes.

FPN: For commercial garages, repair and storage, see Article 511 in the *NEC*.

Ground. A conducting connection, whether intentional or accidental, between an electrical circuit or equipment and the earth or to some conducting body that serves in place of the earth.

Grounded. Connected to earth or to some conducting body that serves in place of the earth.

Grounded, Effectively. Intentionally connected to earth through a ground connection or connections of sufficiently low impedance and having sufficient current-carrying capacity to prevent the buildup of voltages that may result in undue hazards to connected equipment or to persons.

Grounded, Solidly. Connected to ground without inserting any resistor or impedance device.

Grounded Conductor. A system or circuit conductor that is intentionally grounded.

Ground-Fault Circuit Interrupter (GFCI). A device intended for the protection of personnel that functions to de-energize a circuit or portion thereof within an established period of time when a current to ground exceeds the values established for a Class A device.

FPN: Class A ground-fault circuit interrupters trip when the current to ground has a value in the range of 4 mA to 6 mA. For further information, see UL 943, Standard for Ground-Fault Circuit Interrupters.

Ground-Fault Protection of Equipment. A system intended to provide protection of equipment from damaging line-to-ground fault currents by operating to cause a disconnecting means to open all ungrounded conductors of the faulted circuit. This protection is provided at current levels less than those required to protect conductors from damage through the operation of a supply circuit overcurrent device.

Grounding Conductor. A conductor used to connect equipment or the grounded circuit of a wiring system to a grounding electrode or electrodes.

Grounding Conductor, Equipment. The conductor used to connect the non-current-carrying metal parts of equipment, raceways, and other enclosures to the system grounded conductor, the grounding electrode conductor, or both, at the service equipment or at the source of a separately derived system.

Grounding Electrode. A device that establishes an electrical connection to the earth.

Grounding Electrode Conductor. The conductor used to connect the grounding electrode(s) to the equipment grounding conductor, to the grounded conductor, or to both, at the service, at each building or structure where supplied by a

feeder(s) or branch circuit(s), or at the source of a separately derived system.

Guarded. Covered, shielded, fenced, enclosed, or otherwise protected by means of suitable covers, casings, barriers, rails, screens, mats, or platforms to remove the likelihood of approach or contact by persons or objects to a point of danger.

Handhole Enclosure. An enclosure identified for use in underground systems, provided with an open or closed bottom, and sized to allow personnel to reach into, but not enter, for the purpose of installing, operating, or maintaining equipment or wiring or both.

Identified (as applied to equipment). Recognizable as suitable for the specific purpose, function, use, environment, application, and so forth, where described in a particular *Code* requirement.

FPN: Some examples of ways to determine suitability of equipment for a specific purpose, environment, or application include investigations by a qualified testing laboratory (listing and labeling), an inspection agency, or other organizations concerned with product evaluation.

In Sight From (Within Sight From, Within Sight). Where this *Code* specifies that one equipment shall be “in sight from,” “within sight from,” or “within sight,” and so forth, of another equipment, the specified equipment is to be visible and not more than 15 m (50 ft) distant from the other.

Interrupting Rating. The highest current at rated voltage that a device is intended to interrupt under standard test conditions.

FPN: Equipment intended to interrupt current at other than fault levels may have its interrupting rating implied in other ratings, such as horsepower or locked rotor current.

Isolated (as applied to location). Not readily accessible to persons unless special means for access are used.

Labeled. Equipment or materials to which has been attached a label, symbol, or other identifying mark of an organization that is acceptable to the authority having jurisdiction and concerned with product evaluation, that maintains periodic inspection of production of labeled equipment or materials, and by whose labeling the manufacturer indicates compliance with appropriate standards or performance in a specified manner.

Lighting Outlet. An outlet intended for the direct connection of a lampholder, a luminaire (lighting fixture), or a pendant cord terminating in a lampholder.

Listed. Equipment, materials, or services included in a list published by an organization that is acceptable to the authority having jurisdiction and concerned with evaluation of products or services, that maintains periodic inspection of

production of listed equipment or materials or periodic evaluation of services, and whose listing states that the equipment, material, or services either meets appropriate designated standards or has been tested and found suitable for a specified purpose.

FPN: The means for identifying listed equipment may vary for each organization concerned with product evaluation, some of which do not recognize equipment as listed unless it is also labeled. Use of the system employed by the listing organization allows the authority having jurisdiction to identify a listed product.

Live Parts. Energized conductive components.

Location, Damp. Locations protected from weather and not subject to saturation with water or other liquids but subject to moderate degrees of moisture. Examples of such locations include partially protected locations under canopies, marquees, roofed open porches, and like locations, and interior locations subject to moderate degrees of moisture, such as some basements, some barns, and some cold-storage warehouses.

Location, Dry. A location not normally subject to dampness or wetness. A location classified as dry may be temporarily subject to dampness or wetness, as in the case of a building under construction.

Location, Wet. Installations under ground or in concrete slabs or masonry in direct contact with the earth; in locations subject to saturation with water or other liquids, such as vehicle washing areas; and in unprotected locations exposed to weather.

Luminaire. A complete lighting unit consisting of a lamp or lamps together with the parts designed to distribute the light, to position and protect the lamps and ballast (where applicable), and to connect the lamps to the power supply.

Multioutlet Assembly. A type of surface, flush, or free-standing raceway designed to hold conductors and receptacles, assembled in the field or at the factory.

Outlet. A point on the wiring system at which current is taken to supply utilization equipment.

Overcurrent. Any current in excess of the rated current of equipment or the ampacity of a conductor. It may result from overload, short circuit, or ground fault.

FPN: A current in excess of rating may be accommodated by certain equipment and conductors for a given set of conditions. Therefore, the rules for overcurrent protection are specific for particular situations.

Overload. Operation of equipment in excess of normal, full-load rating, or of a conductor in excess of rated ampacity that, when it persists for a sufficient length of time, would cause damage or dangerous overheating. A fault, such as a short circuit or ground fault, is not an overload.

Panelboard. A single panel or group of panel units designed for assembly in the form of a single panel, including buses and automatic overcurrent devices, and equipped with or without switches for the control of light, heat, or power circuits; designed to be placed in a cabinet or cutout box placed in or against a wall, partition, or other support; and accessible only from the front.

Plenum. A compartment or chamber to which one or more air ducts are connected and that forms part of the air distribution system.

Power Outlet. An enclosed assembly that may include receptacles, circuit breakers, fuseholders, fused switches, buses, and watt-hour meter mounting means; intended to supply and control power to mobile homes, recreational vehicles, park trailers, or boats or to serve as a means for distributing power required to operate mobile or temporarily installed equipment.

Premises Wiring (System). That interior and exterior wiring, including power, lighting, control, and signal circuit wiring together with all their associated hardware, fittings, and wiring devices, both permanently and temporarily installed, that extends from the service point or source of power, such as a battery, a solar photovoltaic system, or a generator, transformer, or converter windings, to the outlet(s). Such wiring does not include wiring internal to appliances, luminaires (fixtures), motors, controllers, motor control centers, and similar equipment.

Qualified Person. One who has skills and knowledge related to the construction and operation of the electrical equipment and installations and has received safety training on the hazards involved.

FPN: Refer to NFPA 70E-2004, *Standard for Electrical Safety in the Workplace*, for electrical safety training requirements.

Raceway. An enclosed channel of metal or nonmetallic materials designed expressly for holding wires, cables, or busbars, with additional functions as permitted in this *Code*. Raceways include, but are not limited to, rigid metal conduit, rigid nonmetallic conduit, intermediate metal conduit, liquidtight flexible conduit, flexible metallic tubing, flexible metal conduit, electrical nonmetallic tubing, electrical metallic tubing, underfloor raceways, cellular concrete floor raceways, cellular metal floor raceways, surface raceways, wireways, and busways.

Rainproof. Constructed, protected, or treated so as to prevent rain from interfering with the successful operation of the apparatus under specified test conditions.

Raintight. Constructed or protected so that exposure to a beating rain will not result in the entrance of water under specified test conditions.

Receptacle. A receptacle is a contact device installed at the outlet for the connection of an attachment plug. A single receptacle is a single contact device with no other contact device on the same yoke. A multiple receptacle is two or more contact devices on the same yoke.

Receptacle Outlet. An outlet where one or more receptacles are installed.

Remote-Control Circuit. Any electric circuit that controls any other circuit through a relay or an equivalent device.

Service. The conductors and equipment for delivering electric energy from the serving utility to the wiring system of the premises served.

Service Cable. Service conductors made up in the form of a cable.

Service Conductors. The conductors from the service point to the service disconnecting means.

Service Drop. The overhead service conductors from the last pole or other aerial support to and including the splices, if any, connecting to the service-entrance conductors at the building or other structure.

Service-Entrance Conductors, Overhead System. The service conductors between the terminals of the service equipment and a point usually outside the building, clear of building walls, where joined by tap or splice to the service drop.

Service-Entrance Conductors, Underground System. The service conductors between the terminals of the service equipment and the point of connection to the service lateral.

FPN: Where service equipment is located outside the building walls, there may be no service-entrance conductors or they may be entirely outside the building.

Service Equipment. The necessary equipment, usually consisting of a circuit breaker(s) or switch(es) and fuse(s) and their accessories, connected to the load end of service conductors to a building or other structure, or an otherwise designated area, and intended to constitute the main control and cutoff of the supply.

Service Lateral. The underground service conductors between the street main, including any risers at a pole or other structure or from transformers, and the first point of connection to the service-entrance conductors in a terminal box or meter or other enclosure, inside or outside the building wall. Where there is no terminal box, meter, or other enclosure, the point of connection is considered to be the point of entrance of the service conductors into the building.

Service Point. The point of connection between the facilities of the serving utility and the premises wiring.

Signaling Circuit. Any electric circuit that energizes signaling equipment.

Solar Photovoltaic System. The total components and subsystems that, in combination, convert solar energy into electrical energy suitable for connection to a utilization load.

Special Permission. The written consent of the authority having jurisdiction.

Structure. That which is built or constructed.

Switch, General-Use. A switch intended for use in general distribution and branch circuits. It is rated in amperes, and it is capable of interrupting its rated current at its rated voltage.

Switch, General-Use Snap. A form of general-use switch constructed so that it can be installed in device boxes or on box covers, or otherwise used in conjunction with wiring systems recognized by this *Code*.

Switch, Motor-Circuit. A switch rated in horsepower that is capable of interrupting the maximum operating overload current of a motor of the same horsepower rating as the switch at the rated voltage.

Switch, Transfer. An automatic or nonautomatic device for transferring one or more load conductor connections from one power source to another.

Utilization Equipment. Equipment that utilizes electric energy for electronic, electromechanical, chemical, heating, lighting, or similar purposes.

Ventilated. Provided with a means to permit circulation of air sufficient to remove an excess of heat, fumes, or vapors.

Voltage (of a circuit). The greatest root-mean-square (rms) (effective) difference of potential between any two conductors of the circuit concerned.

FPN: Some systems, such as 3-phase 4-wire, single-phase 3-wire, and 3-wire direct current, may have various circuits of various voltages.

Voltage, Nominal. A nominal value assigned to a circuit or system for the purpose of conveniently designating its voltage class (e.g., 120/240 volts, 480Y/277 volts, 600 volts). The actual voltage at which a circuit operates can vary from the nominal within a range that permits satisfactory operation of equipment.

FPN: See ANSI C84.1-1995, *Voltage Ratings for Electric Power Systems and Equipment (60 Hz)*.

Voltage to Ground. For grounded circuits, the voltage between the given conductor and that point or conductor of the circuit that is grounded; for ungrounded circuits, the greatest voltage between the given conductor and any other conductor of the circuit.

Watertight. Constructed so that moisture will not enter the enclosure under specified test conditions.

Weatherproof. Constructed or protected so that exposure to the weather will not interfere with successful operation.

FPN: Rainproof, raintight, or watertight equipment can fulfill the requirements for weatherproof where varying weather conditions other than wetness, such as snow, ice, dust, or temperature extremes, are not a factor.

ARTICLE 110 Requirements for Electrical Installations

I. General

110.1 Scope. This article covers general requirements for the examination and approval, installation and use, access to and spaces about electrical conductors and equipment; enclosures intended for personnel entry; and tunnel installations.

110.2 Approval. The conductors and equipment required or permitted by this *Code* shall be acceptable only if approved.

FPN: See 90.7, Examination of Equipment for Safety, and 110.3, Examination, Identification, Installation, and Use of Equipment. See definitions of *Approved*, *Identified*, *Labeled*, and *Listed*.

110.3 Examination, Identification, Installation, and Use of Equipment.

(A) Examination. In judging equipment, considerations such as the following shall be evaluated:

- (1) Suitability for installation and use in conformity with the provisions of this *Code*

FPN: Suitability of equipment use may be identified by a description marked on or provided with a product to identify the suitability of the product for a specific purpose, environment, or application. Suitability of equipment may be evidenced by listing or labeling.

- (2) Mechanical strength and durability, including, for parts designed to enclose and protect other equipment, the adequacy of the protection thus provided
- (3) Wire-bending and connection space
- (4) Electrical insulation
- (5) Heating effects under normal conditions of use and also under abnormal conditions likely to arise in service
- (6) Arcing effects
- (7) Classification by type, size, voltage, current capacity, and specific use

(8) Other factors that contribute to the practical safeguarding of persons using or likely to come in contact with the equipment

(B) Installation and Use. Listed or labeled equipment shall be installed and used in accordance with any instructions included in the listing or labeling.

110.4 Voltages. Throughout this *Code*, the voltage considered shall be that at which the circuit operates. The voltage rating of electrical equipment shall not be less than the nominal voltage of a circuit to which it is connected.

110.5 Conductors. Conductors normally used to carry current shall be of copper unless otherwise provided in this *Code*. Where the conductor material is not specified, the material and the sizes given in this *Code* shall apply to copper conductors. Where other materials are used, the size shall be changed accordingly.

FPN: For aluminum and copper-clad aluminum conductors, see 310.15.

110.6 Conductor Sizes. Conductor sizes are expressed in American Wire Gage (AWG) or in circular mils.

110.7 Insulation Integrity. Completed wiring installations shall be free from short circuits and from grounds other than as required or permitted in Article 250.

110.8 Wiring Methods. Only wiring methods recognized as suitable are included in this *Code*. The recognized methods of wiring shall be permitted to be installed in any type of building or occupancy, except as otherwise provided in this *Code*.

110.9 Interrupting Rating. Equipment intended to interrupt current at fault levels shall have an interrupting rating sufficient for the nominal circuit voltage and the current that is available at the line terminals of the equipment.

Equipment intended to interrupt current at other than fault levels shall have an interrupting rating at nominal circuit voltage sufficient for the current that must be interrupted.

110.10 Circuit Impedance and Other Characteristics. The overcurrent protective devices, the total impedance, the component short-circuit current ratings, and other characteristics of the circuit to be protected shall be selected and coordinated to permit the circuit-protective devices used to clear a fault to do so without extensive damage to the electrical components of the circuit. This fault shall be assumed to be either between two or more of the circuit conductors or between any circuit conductor and the grounding conductor or enclosing metal raceway. Listed products applied in

accordance with their listing shall be considered to meet the requirements of this section.

110.11 Deteriorating Agents. Unless identified for use in the operating environment, no conductors or equipment shall be located in damp or wet locations; where exposed to gases, fumes, vapors, liquids, or other agents that have a deteriorating effect on the conductors or equipment; or where exposed to excessive temperatures.

FPN No. 1: See 300.6 for protection against corrosion.

FPN No. 2: Some cleaning and lubricating compounds can cause severe deterioration of many plastic materials used for insulating and structural applications in equipment.

Equipment identified only as “dry locations,” “Type 1,” or “indoor use only” shall be protected against permanent damage from the weather during building construction.

110.12 Mechanical Execution of Work. Electrical equipment shall be installed in a neat and workmanlike manner.

FPN: Accepted industry practices are described in ANSI/NECA 1-2000, *Standard Practices for Good Workmanship in Electrical Contracting*, and other ANSI-approved installation standards.

(A) Unused Openings. Unused cable or raceway openings in boxes, raceways, auxiliary gutters, cabinets, cutout boxes, meter socket enclosures, equipment cases, or housings shall be effectively closed to afford protection substantially equivalent to the wall of the equipment. Where metallic plugs or plates are used with nonmetallic enclosures, they shall be recessed at least 6 mm ($\frac{1}{8}$ in.) from the outer surface of the enclosure.

(B) Subsurface Enclosures. Conductors shall be racked to provide ready and safe access in underground and subsurface enclosures into which persons enter for installation and maintenance.

(C) Integrity of Electrical Equipment and Connections. Internal parts of electrical equipment, including busbars, wiring terminals, insulators, and other surfaces, shall not be damaged or contaminated by foreign materials such as paint, plaster, cleaners, abrasives, or corrosive residues. There shall be no damaged parts that may adversely affect safe operation or mechanical strength of the equipment such as parts that are broken; bent; cut; or deteriorated by corrosion, chemical action, or overheating.

110.13 Mounting and Cooling of Equipment.

(A) Mounting. Electrical equipment shall be firmly secured to the surface on which it is mounted. Wooden plugs driven into holes in masonry, concrete, plaster, or similar materials shall not be used.

(B) Cooling. Electrical equipment that depends on the natural circulation of air and convection principles for cooling of exposed surfaces shall be installed so that room airflow over such surfaces is not prevented by walls or by adjacent installed equipment. For equipment designed for floor mounting, clearance between top surfaces and adjacent surfaces shall be provided to dissipate rising warm air.

Electrical equipment provided with ventilating openings shall be installed so that walls or other obstructions do not prevent the free circulation of air through the equipment.

110.14 Electrical Connections. Because of different characteristics of dissimilar metals, devices such as pressure terminal or pressure splicing connectors and soldering lugs shall be identified for the material of the conductor and shall be properly installed and used. Conductors of dissimilar metals shall not be intermixed in a terminal or splicing connector where physical contact occurs between dissimilar conductors (such as copper and aluminum, copper and copper-clad aluminum, or aluminum and copper-clad aluminum), unless the device is identified for the purpose and conditions of use. Materials such as solder, fluxes, inhibitors, and compounds, where employed, shall be suitable for the use and shall be of a type that will not adversely affect the conductors, installation, or equipment.

FPN: Many terminations and equipment are marked with a tightening torque.

(A) Terminals. Connection of conductors to terminal parts shall ensure a thoroughly good connection without damaging the conductors and shall be made by means of pressure connectors (including set-screw type), solder lugs, or splices to flexible leads. Connection by means of wire-binding screws or studs and nuts that have upturned lugs or the equivalent shall be permitted for 10 AWG or smaller conductors.

Terminals for more than one conductor and terminals used to connect aluminum shall be so identified.

(B) Splices. Conductors shall be spliced or joined with splicing devices identified for the use or by brazing, welding, or soldering with a fusible metal or alloy. Soldered splices shall first be spliced or joined so as to be mechanically and electrically secure without solder and then be soldered. All splices and joints and the free ends of conductors shall be covered with an insulation equivalent to that of the conductors or with an insulating device identified for the purpose.

Wire connectors or splicing means installed on conductors for direct burial shall be listed for such use.

(C) Temperature Limitations. The temperature rating associated with the ampacity of a conductor shall be selected and coordinated so as not to exceed the lowest temperature rating of any connected termination, conductor, or device. Conductors with temperature ratings higher than specified

for terminations shall be permitted to be used for ampacity adjustment, correction, or both.

(1) Equipment Provisions. The determination of termination provisions of equipment shall be based on 110.14(C)(1)(a) or (C)(1)(b). Unless the equipment is listed and marked otherwise, conductor ampacities used in determining equipment termination provisions shall be based on Table 310.16 as appropriately modified by 310.15(B)(6).

(a) Termination provisions of equipment for circuits rated 100 amperes or less, or marked for 14 AWG through 1 AWG conductors, shall be used only for one of the following:

- (1) Conductors rated 60°C (140°F).
- (2) Conductors with higher temperature ratings, provided the ampacity of such conductors is determined based on the 60°C (140°F) ampacity of the conductor size used.
- (3) Conductors with higher temperature ratings if the equipment is listed and identified for use with such conductors.
- (4) For motors marked with design letters B, C, or D, conductors having an insulation rating of 75°C (167°F) or higher shall be permitted to be used, provided the ampacity of such conductors does not exceed the 75°C (167°F) ampacity.

(b) Termination provisions of equipment for circuits rated over 100 amperes, or marked for conductors larger than 1 AWG, shall be used only for one of the following:

- (1) Conductors rated 75°C (167°F)
- (2) Conductors with higher temperature ratings, provided the ampacity of such conductors does not exceed the 75°C (167°F) ampacity of the conductor size used, or up to their ampacity if the equipment is listed and identified for use with such conductors

(2) Separate Connector Provisions. Separately installed pressure connectors shall be used with conductors at the ampacities not exceeding the ampacity at the listed and identified temperature rating of the connector.

FPN: With respect to 110.14(C)(1) and (C)(2), equipment markings or listing information may additionally restrict the sizing and temperature ratings of connected conductors.

110.15 High-Leg Marking. On a 4-wire, delta-connected system where the midpoint of one phase winding is grounded, only the conductor or busbar having the higher phase voltage to ground shall be durably and permanently marked by an outer finish that is orange in color or by other effective means. Such identification shall be placed at each point on the system where a connection is made if the grounded conductor is also present.

110.18 Arcing Parts. Parts of electric equipment that in ordinary operation produce arcs, sparks, flames, or molten

metal shall be enclosed or separated and isolated from all combustible material.

110.19 Light and Power from Railway Conductors. Circuits for lighting and power shall not be connected to any system that contains trolley wires with a ground return.

Exception: Such circuit connections shall be permitted in car houses, power houses, or passenger and freight stations operated in connection with electric railways.

110.21 Marking. The manufacturer’s name, trademark, or other descriptive marking by which the organization responsible for the product can be identified shall be placed on all electric equipment. Other markings that indicate voltage, current, wattage, or other ratings shall be provided as specified elsewhere in this *Code*. The marking shall be of sufficient durability to withstand the environment involved.

110.22 Identification of Disconnecting Means. Each disconnecting means shall be legibly marked to indicate its purpose unless located and arranged so the purpose is evident. The marking shall be of sufficient durability to withstand the environment involved.

Where circuit breakers or fuses are applied in compliance with the series combination ratings marked on the equipment by the manufacturer, the equipment enclosure(s) shall be legibly marked in the field to indicate the equipment has been applied with a series combination rating. The marking shall be readily visible and state the following:

**CAUTION — SERIES COMBINATION
SYSTEM RATED _____ AMPERES. IDENTIFIED
REPLACEMENT
COMPONENTS REQUIRED.**

110.23 Current Transformers. Unused current transformers associated with potentially energized circuits shall be short-circuited.

II. 600 Volts, Nominal, or Less

110.26 Spaces About Electrical Equipment. Sufficient access and working space shall be provided and maintained about all electric equipment to permit ready and safe operation and maintenance of such equipment. Enclosures housing electrical apparatus that are controlled by a lock(s) shall be considered accessible to qualified persons.

(A) Working Space. Working space for equipment operating at 600 volts, nominal, or less to ground and likely to require examination, adjustment, servicing, or maintenance while energized shall comply with the dimensions of 110.26(A)(1), (A)(2), and (A)(3) or as required or permitted elsewhere in this *Code*.

(1) Depth of Working Space. The depth of the working space in the direction of live parts shall not be less than that

specified in Table 110.26(A)(1) unless the requirements of 110.26(A)(1)(a), (A)(1)(b), or (A)(1)(c) are met. Distances shall be measured from the exposed live parts or from the enclosure or opening if the live parts are enclosed.

Table 110.26(A)(1) Working Spaces

Nominal Voltage to Ground	Minimum Clear Distance		
	Condition 1	Condition 2	Condition 3
0–150	900 mm (3 ft)	900 mm (3 ft)	900 mm (3 ft)
151–600	900 mm (3 ft)	1.1 m (3½ ft)	1.2 m (4 ft)

Note: Where the conditions are as follows:
 Condition 1—Exposed live parts on one side of the working space and no live or grounded parts on the other side of the working space, or exposed live parts on both sides of the working space that are effectively guarded by insulating materials.
 Condition 2—Exposed live parts on one side of the working space and grounded parts on the other side of the working space. Concrete, brick, or tile walls shall be considered as grounded.
 Condition 3—Exposed live parts on both sides of the working space.

(a) **Dead-Front Assemblies.** Working space shall not be required in the back or sides of assemblies, such as dead-front switchboards or motor control centers, where all connections and all renewable or adjustable parts, such as fuses or switches, are accessible from locations other than the back or sides. Where rear access is required to work on nonelectrical parts on the back of enclosed equipment, a minimum horizontal working space of 762 mm (30 in.) shall be provided.

(b) **Low Voltage.** By special permission, smaller working spaces shall be permitted where all exposed live parts operate at not greater than 30 volts rms, 42 volts peak, or 60 volts dc.

(c) **Existing Buildings.** In existing buildings where electrical equipment is being replaced, Condition 2 working clearance shall be permitted between dead-front switchboards, panelboards, or motor control centers located across the aisle from each other where conditions of maintenance and supervision ensure that written procedures have been adopted to prohibit equipment on both sides of the aisle from being open at the same time and qualified persons who are authorized will service the installation.

(2) Width of Working Space. The width of the working space in front of the electric equipment shall be the width of the equipment or 750 mm (30 in.), whichever is greater. In all cases, the work space shall permit at least a 90 degree opening of equipment doors or hinged panels.

(3) Height of Working Space. The work space shall be clear and extend from the grade, floor, or platform to the height required by 110.26(E). Within the height requirements of this section, other equipment that is associated with the electrical installation and is located above or below the electrical equipment shall be permitted to extend not more than 150 mm (6 in.) beyond the front of the electrical equipment.

(B) Clear Spaces. Working space required by this section shall not be used for storage. When normally enclosed live parts are exposed for inspection or servicing, the working space, if in a passageway or general open space, shall be suitably guarded.

(C) Entrance to Working Space.

(1) Minimum Required. At least one entrance of sufficient area shall be provided to give access to working space about electrical equipment.

(2) Large Equipment. For equipment rated 1200 amperes or more that contains overcurrent devices, switching devices, or control devices, there shall be one entrance to the required working space not less than 610 mm (24 in.) wide and 2.0 m (6½ ft) high at each end of the working space. Where the entrance has a personnel door(s), the door(s) shall open in the direction of egress and be equipped with panic bars, pressure plates, or other devices that are normally latched but open under simple pressure.

A single entrance to the required working space shall be permitted where either of the conditions in 110.26(C)(2)(a) or (C)(2)(b) is met.

(a) Unobstructed Exit. Where the location permits a continuous and unobstructed way of exit travel, a single entrance to the working space shall be permitted.

(b) Extra Working Space. Where the depth of the working space is twice that required by 110.26(A)(1), a single entrance shall be permitted. It shall be located so that the distance from the equipment to the nearest edge of the entrance is not less than the minimum clear distance specified in Table 110.26(A)(1) for equipment operating at that voltage and in that condition.

(D) Illumination. Illumination shall be provided for all working spaces about service equipment, switchboards, panelboards, or motor control centers installed indoors. Additional lighting outlets shall not be required where the work space is illuminated by an adjacent light source or as permitted by 210.70(A)(1), Exception No. 1, for switched receptacles. In electrical equipment rooms, the illumination shall not be controlled by automatic means only.

(E) Headroom. The minimum headroom of working spaces about service equipment, switchboards, panelboards, or motor control centers shall be 2.0 m (6½ ft). Where the

electrical equipment exceeds 2.0 m (6½ ft) in height, the minimum headroom shall not be less than the height of the equipment.

Exception: In existing dwelling units, service equipment or panelboards that do not exceed 200 amperes shall be permitted in spaces where the headroom is less than 2.0 m (6½ ft).

(F) Dedicated Equipment Space. All switchboards, panelboards, distribution boards, and motor control centers shall be located in dedicated spaces and protected from damage.

Exception: Control equipment that by its very nature or because of other rules of the Code must be adjacent to or within sight of its operating machinery shall be permitted in those locations.

(1) Indoor. Indoor installations shall comply with 110.26(F)(1)(a) through (F)(1)(d).

(a) Dedicated Electrical Space. The space equal to the width and depth of the equipment and extending from the floor to a height of 1.8 m (6 ft) above the equipment or to the structural ceiling, whichever is lower, shall be dedicated to the electrical installation. No piping, ducts, leak protection apparatus, or other equipment foreign to the electrical installation shall be located in this zone.

Exception: Suspended ceilings with removable panels shall be permitted within the 1.8 m (6 ft) zone.

(b) Foreign Systems. The area above the dedicated space required by 110.26(F)(1)(a) shall be permitted to contain foreign systems, provided protection is installed to avoid damage to the electrical equipment from condensation, leaks, or breaks in such foreign systems.

(c) Sprinkler Protection. Sprinkler protection shall be permitted for the dedicated space where the piping complies with this section.

(d) Suspended Ceilings. A dropped, suspended, or similar ceiling that does not add strength to the building structure shall not be considered a structural ceiling.

(2) Outdoor. Outdoor electrical equipment shall be installed in suitable enclosures and shall be protected from accidental contact by unauthorized personnel, or by vehicular traffic, or by accidental spillage or leakage from piping systems. The working clearance space shall include the zone described in 110.26(A). No architectural appurtenance or other equipment shall be located in this zone.

110.27 Guarding of Live Parts.

(A) Live Parts Guarded Against Accidental Contact. Except as elsewhere required or permitted by this Code, live parts of electrical equipment operating at 50 volts or more shall be guarded against accidental contact by approved enclosures.

Chapter 2 Wiring and Protection

ARTICLE 200 Use and Identification of Grounded Conductors

200.1 Scope. This article provides requirements for the following:

- (1) Identification of terminals
- (2) Grounded conductors in premises wiring systems
- (3) Identification of grounded conductors

FPN: See Article 100 for definitions of *Grounded Conductor* and *Grounding Conductor*.

200.2 General. All premises wiring systems, other than circuits and systems exempted or prohibited by 210.10, 215.7, 250.21 in the *NEC* and 250.22 in the *NEC*, shall have a grounded conductor that is identified in accordance with 200.6.

The grounded conductor, where insulated, shall have insulation that is (1) suitable, other than color, for any ungrounded conductor of the same circuit on circuits of less than 1000 volts.

200.3 Connection to Grounded System. Premises wiring shall not be electrically connected to a supply system unless the latter contains, for any grounded conductor of the interior system, a corresponding conductor that is grounded. For the purpose of this section, electrically connected shall mean connected so as to be capable of carrying current, as distinguished from connection through electromagnetic induction.

200.6 Means of Identifying Grounded Conductors.

(A) Sizes 6 AWG or Smaller. An insulated grounded conductor of 6 AWG or smaller shall be identified by a continuous white or gray outer finish or by three continuous white stripes on other than green insulation along its entire length. Wires that have their outer covering finished to show a white or gray color but have colored tracer threads in the braid identifying the source of manufacture shall be considered as meeting the provisions of this section. Insulated grounded conductors shall also be permitted to be identified as follows:

- (1) The grounded conductor of a mineral-insulated, metal-sheathed cable shall be identified at the time of installation by distinctive marking at its terminations.
- (2) A single-conductor, sunlight-resistant, outdoor-rated cable used as a grounded conductor in photovoltaic

power systems as permitted by 690.31 in the *NEC* shall be identified at the time of installation by distinctive white marking at all terminations.

- (3) Fixture wire shall comply with the requirements for grounded conductor identification as specified in 402.8 in the *NEC*.
- (4) For aerial cable, the identification shall be as above, or by means of a ridge located on the exterior of the cable so as to identify it.

(B) Sizes Larger Than 6 AWG. An insulated grounded conductor larger than 6 AWG shall be identified by one of the following means:

- (1) By a continuous white or gray outer finish.
- (2) By three continuous white stripes along its entire length on other than green insulation.
- (3) At the time of installation, by a distinctive white or gray marking at its terminations. This marking shall encircle the conductor or insulation.

(C) Flexible Cords. An insulated conductor that is intended for use as a grounded conductor, where contained within a flexible cord, shall be identified by a white or gray outer finish or by methods permitted by 400.22 in the *NEC*.

FPN: The color gray may have been used in the past as an ungrounded conductor. Care should be taken when working on existing systems.

200.7 Use of Insulation of a White or Gray Color or with Three Continuous White Stripes.

(A) General. The following shall be used only for the grounded circuit conductor, unless otherwise permitted in 200.7(B) and 200.7(C):

- (1) A conductor with continuous white or gray covering
- (2) A conductor with three continuous white stripes on other than green insulation
- (3) A marking of white or gray color at the termination

(B) Circuits of Less Than 50 Volts. A conductor with white or gray color insulation or three continuous white stripes or having a marking of white or gray at the termination for circuits of less than 50 volts shall be required to be grounded only as required by 250.20(A).

(C) Circuits of 50 Volts or More. The use of insulation that is white or gray or that has three continuous white stripes for other than a grounded conductor for circuits of 50 volts or more shall be permitted only as in (1) through (3).

- (1) If part of a cable assembly and where the insulation is permanently re-identified to indicate its use as an ungrounded conductor, by painting or other effective means at its termination, and at each location where the conductor is visible and accessible. Identification shall encircle the insulation and shall be a color other than white, gray, or green.
- (2) Where a cable assembly contains an insulated conductor for single-pole, 3-way or 4-way switch loops and the conductor with white or gray insulation or a marking of three continuous white stripes is used for the supply to the switch but not as a return conductor from the switch to the switched outlet. In these applications, the conductor with white or gray insulation or with three continuous white stripes shall be permanently re-identified to indicate its use by painting or other effective means at its terminations and at each location where the conductor is visible and accessible.
- (3) Where a flexible cord, having one conductor identified by a white or gray outer finish or three continuous white stripes or by any other means permitted by 400.22 in the *NEC*, is used for connecting an appliance or equipment permitted by 400.7. This shall apply to flexible cords connected to outlets whether or not the outlet is supplied by a circuit that has a grounded conductor.

FPN: The color gray may have been used in the past as an ungrounded conductor. Care should be taken when working on existing systems.

200.9 Means of Identification of Terminals. The identification of terminals to which a grounded conductor is to be connected shall be substantially white in color. The identification of other terminals shall be of a readily distinguishable different color.

Exception: Where the conditions of maintenance and supervision ensure that only qualified persons service the installations, terminals for grounded conductors shall be permitted to be permanently identified at the time of installation by a distinctive white marking or other equally effective means.

200.10 Identification of Terminals.

(A) Device Terminals. All devices, excluding panelboards, provided with terminals for the attachment of conductors and intended for connection to more than one side of the circuit shall have terminals properly marked for identification, unless the electrical connection of the terminal intended to be connected to the grounded conductor is clearly evident.

Exception: Terminal identification shall not be required for devices that have a normal current rating of over 30 amperes, other than polarized attachment plugs and polarized receptacles for attachment plugs as required in 200.10(B).

(B) Receptacles, Plugs, and Connectors. Receptacles, polarized attachment plugs, and cord connectors for plugs and polarized plugs shall have the terminal intended for connection to the grounded conductor identified as follows:

- (1) Identification shall be by a metal or metal coating that is substantially white in color or by the word *white* or the letter *W* located adjacent to the identified terminal.
- (2) If the terminal is not visible, the conductor entrance hole for the connection shall be colored white or marked with the word *white* or the letter *W*.

FPN: See 250.126 for identification of wiring device equipment grounding conductor terminals.

(C) Screw Shells. For devices with screw shells, the terminal for the grounded conductor shall be the one connected to the screw shell.

(D) Screw Shell Devices with Leads. For screw shell devices with attached leads, the conductor attached to the screw shell shall have a white or gray finish. The outer finish of the other conductor shall be of a solid color that will not be confused with the white or gray finish used to identify the grounded conductor.

FPN: The color gray may have been used in the past as an ungrounded conductor. Care should be taken when working on existing systems.

(E) Appliances. Appliances that have a single-pole switch or a single-pole overcurrent device in the line or any line-connected screw shell lampholders, and that are to be connected by (1) a permanent wiring method or (2) field-installed attachment plugs and cords with three or more wires (including the equipment grounding conductor), shall have means to identify the terminal for the grounded circuit conductor (if any).

200.11 Polarity of Connections. No grounded conductor shall be attached to any terminal or lead so as to reverse the designated polarity.

ARTICLE 210 Branch Circuits

I. General Provisions

210.1 Scope. This article covers branch circuits except for branch circuits that supply only motor loads, which are covered in Article 430 in the *NEC*. Provisions of this article and Article 430 in the *NEC* apply to branch circuits with combination loads.

210.2 Other Articles for Specific-Purpose Branch Circuits. Branch circuits shall comply with this article and also with the applicable provisions of other articles of this *Code*. The provisions for branch circuits supplying equipment listed in Table 210.2 amend or supplement the provisions in this article and shall apply to branch circuits referred to therein.

Table 210.2 Specific-Purpose Branch Circuits

Equipment	Article	Section
Air-conditioning and refrigerating equipment		440.6, 440.31, 440.32
Central heating equipment other than fixed electric space-heating equipment		422.12
Class 1, Class 2, and Class 3 remote-control, signaling, and power-limited circuits	725	
Fire alarm systems	760	
Fixed electric space-heating equipment	424.3	

210.3 Rating. Branch circuits recognized by this article shall be rated in accordance with the maximum permitted ampere rating or setting of the overcurrent device. The rating for other than individual branch circuits shall be 15, 20, 30, 40, and 50 amperes. Where conductors of higher ampacity are used for any reason, the ampere rating or setting of the specified overcurrent device shall determine the circuit rating.

210.4 Multiwire Branch Circuits.

(A) General. Branch circuits recognized by this article shall be permitted as multiwire circuits. A multiwire circuit shall be permitted to be considered as multiple circuits. All conductors shall originate from the same panelboard or similar distribution equipment.

FPN: A 3-phase, 4-wire, wye-connected power system used to supply power to nonlinear loads may necessitate that the power system design allow for the possibility of high harmonic neutral currents.

(B) Devices or Equipment. Where a multiwire branch circuit supplies more than one device or equipment on the same yoke, a means shall be provided to disconnect simultaneously all ungrounded conductors supplying those devices or equipment at the point where the branch circuit originates.

(C) Line-to-Neutral Loads. Multiwire branch circuits shall supply only line-to-neutral loads.

Exception No. 1: A multiwire branch circuit that supplies only one utilization equipment.

Exception No. 2: Where all ungrounded conductors of the multiwire branch circuit are opened simultaneously by the branch-circuit overcurrent device.

FPN: See 300.13(B) for continuity of grounded conductor on multiwire circuits.

210.5 Identification for Branch Circuits.

(A) Grounded Conductor. The grounded conductor of a branch circuit shall be identified in accordance with 200.6.

(B) Equipment Grounding Conductor. The equipment grounding conductor shall be identified in accordance with 250.119.

210.6 Branch-Circuit Voltage Limitations. The nominal voltage of branch circuits shall not exceed the values permitted by 210.6(A) through 210.6(C).

(A) Occupancy Limitation. In dwelling units and guest rooms or guest suites of hotels, motels, and similar occupancies, the voltage shall not exceed 120 volts, nominal, between conductors that supply the terminals of the following:

- (1) Luminaires (lighting fixtures)
- (2) Cord-and-plug-connected loads 1440 volt-amperes, nominal, or less or less than ¼ hp

(B) 120 Volts Between Conductors. Circuits not exceeding 120 volts, nominal, between conductors shall be permitted to supply the following:

- (1) The terminals of lampholders applied within their voltage ratings
- (2) Auxiliary equipment of electric-discharge lamps
- (3) Cord-and-plug-connected or permanently connected utilization equipment

(C) 277 Volts to Ground. Circuits exceeding 120 volts, nominal, between conductors and not exceeding 277 volts, nominal, to ground shall be permitted to supply the following:

- (1) Listed electric-discharge luminaires (lighting fixtures)
- (2) Listed incandescent luminaires (lighting fixtures), where supplied at 120 volts or less from the output of a stepdown autotransformer that is an integral component of the luminaire (fixture) and the outer shell terminal is electrically connected to a grounded conductor of the branch circuit
- (3) Luminaires (lighting fixtures) equipped with mogul-base screw shell lampholders
- (4) Lampholders, other than the screw shell type, applied within their voltage ratings
- (5) Auxiliary equipment of electric-discharge lamps

- (6) Cord-and-plug-connected or permanently connected utilization equipment

210.7 Branch Circuit Receptacle Requirements.

(A) Receptacle Outlet Location. Receptacle outlets shall be located in branch circuits in accordance with Part III of Article 210.

(B) Multiple Branch Circuits. Where two or more branch circuits supply devices or equipment on the same yoke, a means to simultaneously disconnect the ungrounded conductors supplying those devices shall be provided at the point at which the branch circuits originate.

210.8 Ground-Fault Circuit-Interrupter Protection for Personnel.

FPN: See 215.9 for ground-fault circuit-interrupter protection for personnel on feeders.

(A) Dwelling Units. All 125-volt, single-phase, 15- and 20-ampere receptacles installed in the locations specified in (1) through (8) shall have ground-fault circuit-interrupter protection for personnel.

- (1) Bathrooms
- (2) Garages, and also accessory buildings that have a floor located at or below grade level not intended as habitable rooms and limited to storage areas, work areas, and areas of similar use

Exception No. 1 to (2): Receptacles that are not readily accessible.

Exception No. 2 to (2): A single receptacle or a duplex receptacle for two appliances located within dedicated space for each appliance that, in normal use, is not easily moved from one place to another and that is cord-and-plug connected in accordance with 400.7(A)(6), (A)(7), or (A)(8).

Receptacles installed under the exceptions to 210.8(A)(2) shall not be considered as meeting the requirements of 210.52(G)

- (3) Outdoors

Exception to (3): Receptacles that are not readily accessible and are supplied by a dedicated branch circuit for electric snow-melting or deicing equipment shall be permitted to be installed in accordance with 426.28 in the NEC.

- (4) Crawl spaces — at or below grade level
- (5) Unfinished basements — for purposes of this section, unfinished basements are defined as portions or areas of the basement not intended as habitable rooms and limited to storage areas, work areas, and the like

Exception No. 1 to (5): Receptacles that are not readily accessible.

Exception No. 2 to (5): A single receptacle or a duplex receptacle for two appliances located within dedicated space for each appliance that, in normal use, is not easily moved from one place to another and that is cord-and-plug connected in accordance with 400.7(A)(6), (A)(7), or (A)(8).

Exception No. 3 to (5): A receptacle supplying only a permanently installed fire alarm or burglar alarm system shall not be required to have ground-fault circuit-interrupter protection.

Receptacles installed under the exceptions to 210.8(A)(5) shall not be considered as meeting the requirements of 210.52(G).

- (6) Kitchens — where the receptacles are installed to serve the countertop surfaces
- (7) Laundry, utility, and wet bar sinks — where the receptacles are installed within 1.8 m (6 ft) of the outside edge of the sink
- (8) Boathouses

(C) Boat Hoists. Ground-fault circuit-interrupter protection for personnel shall be provided for outlets that supply boat hoists installed in dwelling unit locations and supplied by 125-volt, 15- and 20-ampere branch circuits.

210.10 Ungrounded Conductors Tapped from Grounded Systems.

Two-wire dc circuits and ac circuits of two or more ungrounded conductors shall be permitted to be tapped from the ungrounded conductors of circuits that have a grounded neutral conductor. Switching devices in each tapped circuit shall have a pole in each ungrounded conductor. All poles of multipole switching devices shall manually switch together where such switching devices also serve as a disconnecting means as required by the following:

- (1) 410.48 for double-pole switched lampholders
- (2) 422.31(B) for an appliance
- (3) 424.20 for a fixed electric space-heating unit
- (4) 426.51 in the *NEC* for electric deicing and snow-melting equipment
- (5) 430.85 in the *NEC* for a motor controller
- (6) 430.103 in the *NEC* for a motor

210.11 Branch Circuits Required. Branch circuits for lighting and for appliances, including motor-operated appliances, shall be provided to supply the loads calculated in accordance with 220.10. In addition, branch circuits shall be provided for specific loads not covered by 220.10 where required elsewhere in this *Code* and for dwelling unit loads as specified in 210.11(C).

(A) Number of Branch Circuits. The minimum number of branch circuits shall be determined from the total calculated load and the size or rating of the circuits used. In all installations, the number of circuits shall be sufficient to supply the load served. In no case shall the load on any circuit exceed the maximum specified by 220.18.

(B) Load Evenly Proportioned Among Branch Circuits. Where the load is calculated on the basis of volt-amperes per square meter or per square foot, the wiring system up to and including the branch-circuit panelboard(s) shall be provided to serve not less than the calculated load. This load shall be evenly proportioned among multioutlet branch circuits within the panelboard(s). Branch-circuit overcurrent devices and circuits shall only be required to be installed to serve the connected load.

(C) Dwelling Units.

(1) Small-Appliance Branch Circuits. In addition to the number of branch circuits required by other parts of this section, two or more 20-ampere small-appliance branch circuits shall be provided for all receptacle outlets specified by 210.52(B).

(2) Laundry Branch Circuits. In addition to the number of branch circuits required by other parts of this section, at least one additional 20-ampere branch circuit shall be provided to supply the laundry receptacle outlet(s) required by 210.52(F). This circuit shall have no other outlets.

(3) Bathroom Branch Circuits. In addition to the number of branch circuits required by other parts of this section, at least one 20-ampere branch circuit shall be provided to supply bathroom receptacle outlet(s). Such circuits shall have no other outlets.

Exception: Where the 20-ampere circuit supplies a single bathroom, outlets for other equipment within the same bathroom shall be permitted to be supplied in accordance with 210.23(A)(1) and (A)(2).

FPN: See Examples D1(a), D1(b), and D2(b), in Annex D.

210.12 Arc-Fault Circuit-Interrupter Protection.

(A) Definition: Arc-Fault Circuit Interrupter. An arc-fault circuit interrupter is a device intended to provide protection from the effects of arc faults by recognizing characteristics unique to arcing and by functioning to de-energize the circuit when an arc fault is detected.

(B) Dwelling Unit Bedrooms. All 120-volt, single phase, 15- and 20-ampere branch circuits supplying outlets installed in dwelling unit bedrooms shall be protected by a listed arc-fault circuit interrupter, combination type installed to provide protection of the branch circuit.

Branch/feeder AFCIs shall be permitted to be used to meet the requirements of 210.12(B) until January 1, 2008.

FPN: For information on types of arc-fault circuit interrupters, see UL 1699-1999, *Standard for Arc-Fault Circuit Interrupters*.

Exception: The location of the arc-fault circuit interrupter shall be permitted to be at other than the origination of the branch circuit in compliance with (a) and (b):

- (a) *The arc-fault circuit interrupter installed within 1.8 m (6 ft) of the branch circuit overcurrent device as measured along the branch circuit conductors.*
- (b) *The circuit conductors between the branch circuit overcurrent device and the arc-fault circuit interrupter shall be installed in a metal raceway or a cable with a metallic sheath.*

II. Branch-Circuit Ratings

210.19 Conductors — Minimum Ampacity and Size.

(A) Branch Circuits Not More Than 600 Volts.

(1) General. Branch-circuit conductors shall have an ampacity not less than the maximum load to be served. Where a branch circuit supplies continuous loads or any combination of continuous and noncontinuous loads, the minimum branch-circuit conductor size, before the application of any adjustment or correction factors, shall have an allowable ampacity not less than the noncontinuous load plus 125 percent of the continuous load.

Exception: Where the assembly, including the overcurrent devices protecting the branch circuit(s), is listed for operation at 100 percent of its rating, the allowable ampacity of the branch circuit conductors shall be permitted to be not less than the sum of the continuous load plus the noncontinuous load.

FPN No. 1: See 310.15 for ampacity ratings of conductors.

FPN No. 2: See Part II of Article 430 in the *NEC* for minimum rating of motor branch-circuit conductors.

FPN No. 3: See 310.10 for temperature limitation of conductors.

FPN No. 4: Conductors for branch circuits as defined in Article 100, sized to prevent a voltage drop exceeding 3 percent at the farthest outlet of power, heating, and lighting loads, or combinations of such loads, and where the maximum total voltage drop on both feeders and branch circuits to the farthest outlet does not exceed 5 percent, provide reasonable efficiency of operation. See FPN No. 2 of 215.2(A)(3) for voltage drop on feeder conductors.

(2) Multioutlet Branch Circuits. Conductors of branch circuits supplying more than one receptacle for cord-and-

plug-connected portable loads shall have an ampacity of not less than the rating of the branch circuit.

(3) Household Ranges and Cooking Appliances. Branch-circuit conductors supplying household ranges, wall-mounted ovens, counter-mounted cooking units, and other household cooking appliances shall have an ampacity not less than the rating of the branch circuit and not less than the maximum load to be served. For ranges of 8¾ kW or more rating, the minimum branch-circuit rating shall be 40 amperes.

Exception No. 1: Tap conductors supplying electric ranges, wall-mounted electric ovens, and counter-mounted electric cooking units from a 50-ampere branch circuit shall have an ampacity of not less than 20 and shall be sufficient for the load to be served. These tap conductors include any conductors that are a part of the leads supplied with the appliance that are smaller than the branch circuit conductors. The taps shall not be longer than necessary for servicing the appliance.

Exception No. 2: The neutral conductor of a 3-wire branch circuit supplying a household electric range, a wall-mounted oven, or a counter-mounted cooking unit shall be permitted to be smaller than the ungrounded conductors where the maximum demand of a range of 8¾ kW or more rating has been calculated according to Column C of Table 220.55, but such conductor shall have an ampacity of not less than 70 percent of the branch-circuit rating and shall not be smaller than 10 AWG.

(4) Other Loads. Branch-circuit conductors that supply loads other than those specified in 210.2 and other than cooking appliances as covered in 210.19(A)(3) shall have an ampacity sufficient for the loads served and shall not be smaller than 14 AWG.

Exception No. 1: Tap conductors shall have an ampacity sufficient for the load served. In addition, they shall have an ampacity of not less than 15 for circuits rated less than 40 amperes and not less than 20 for circuits rated at 40 or 50 amperes and only where these tap conductors supply any of the following loads:

- (a) Individual lampholders or luminaires (fixtures) with taps extending not longer than 450 mm (18 in.) beyond any portion of the lampholder or luminaire (fixture).
- (b) A fixture having tap conductors as provided in 410.67.
- (c) Individual outlets, other than receptacle outlets, with taps not over 450 mm (18 in.) long.
- (d) Infrared lamp industrial heating appliances.
- (e) Nonheating leads of deicing and snow-melting cables and mats.

Exception No. 2: Fixture wires and flexible cords shall be permitted to be smaller than 14 AWG as permitted by 240.5 in the NEC.

210.20 Overcurrent Protection. Branch-circuit conductors and equipment shall be protected by overcurrent protective devices that have a rating or setting that complies with 210.20(A) through (D).

(A) Continuous and Noncontinuous Loads. Where a branch circuit supplies continuous loads or any combination of continuous and noncontinuous loads, the rating of the overcurrent device shall not be less than the noncontinuous load plus 125 percent of the continuous load.

Exception: Where the assembly, including the overcurrent devices protecting the branch circuit(s), is listed for operation at 100 percent of its rating, the ampere rating of the overcurrent device shall be permitted to be not less than the sum of the continuous load plus the noncontinuous load.

(B) Conductor Protection. Conductors shall be protected in accordance with 240.4. Flexible cords and fixture wires shall be protected in accordance with 240.5 in the NEC.

(C) Equipment. The rating or setting of the overcurrent protective device shall not exceed that specified in the applicable articles referenced in Table 240.3 for equipment.

(D) Outlet Devices. The rating or setting shall not exceed that specified in 210.21 for outlet devices.

210.21 Outlet Devices. Outlet devices shall have an ampere rating that is not less than the load to be served and shall comply with 210.21(A) and (B).

(A) Lampholders. Where connected to a branch circuit having a rating in excess of 20 amperes, lampholders shall be of the heavy-duty type. A heavy-duty lampholder shall have a rating of not less than 660 watts if of the admedium type, or not less than 750 watts if of any other type.

(B) Receptacles.

(1) Single Receptacle on an Individual Branch Circuit. A single receptacle installed on an individual branch circuit shall have an ampere rating not less than that of the branch circuit.

Exception No. 1: A receptacle installed in accordance with 430.81(B) in the NEC.

FPN: See the definition of *receptacle* in Article 100.

(2) Total Cord-and-Plug-Connected Load. Where connected to a branch circuit supplying two or more receptacles or outlets, a receptacle shall not supply a total cord-and-

plug-connected load in excess of the maximum specified in Table 210.21(B)(2).

Table 210.21(B)(2) Maximum Cord-and-Plug-Connected Load to Receptacle

Circuit Rating (Amperes)	Receptacle Rating (Amperes)	Maximum Load (Amperes)
15 or 20	15	12
20	20	16
30	30	24

(3) Receptacle Ratings. Where connected to a branch circuit supplying two or more receptacles or outlets, receptacle ratings shall conform to the values listed in Table 210.21(B)(3), or where larger than 50 amperes, the receptacle rating shall not be less than the branch-circuit rating.

Exception No. 2: The ampere rating of a receptacle installed for electric discharge lighting shall be permitted to be based on 410.30(C).

Table 210.21(B)(3) Receptacle Ratings for Various Size Circuits

Circuit Rating (Amperes)	Receptacle Rating (Amperes)
15	Not over 15
20	15 or 20
30	30
40	40 or 50
50	50

(4) Range Receptacle Rating. The ampere rating of a range receptacle shall be permitted to be based on a single range demand load as specified in Table 220.55.

210.23 Permissible Loads. In no case shall the load exceed the branch-circuit ampere rating. An individual branch circuit shall be permitted to supply any load for which it is rated. A branch circuit supplying two or more outlets or receptacles shall supply only the loads specified according to its size as specified in 210.23(A) through (D) and as summarized in 210.24 and Table 210.24.

(A) 15- and 20-Ampere Branch Circuits. A 15- or 20-ampere branch circuit shall be permitted to supply lighting units or other utilization equipment, or a combination of both, and shall comply with 210.23(A)(1) and (A)(2).

Exception: The small appliance branch circuits, laundry branch circuits, and bathroom branch circuits required in a dwelling unit(s) by 210.11(C)(1), (C)(2), and (C)(3) shall supply only the receptacle outlets specified in that section.

(1) Cord-and-Plug-Connected Equipment Not Fastened in Place. The rating of any one cord-and-plug-connected utilization equipment not fastened in place shall not exceed 80 percent of the branch-circuit ampere rating.

(2) Utilization Equipment Fastened in Place. The total rating of utilization equipment fastened in place, other than luminaires (lighting fixtures), shall not exceed 50 percent of the branch-circuit ampere rating where lighting units, cord-and-plug-connected utilization equipment not fastened in place, or both, are also supplied.

(B) 30-Ampere Branch Circuits. A 30-ampere branch circuit shall be permitted to supply fixed lighting units with heavy-duty lampholders in other than a dwelling unit(s) or utilization equipment in any occupancy. A rating of any one cord-and-plug-connected utilization equipment shall not exceed 80 percent of the branch-circuit ampere rating.

(C) 40- and 50-Ampere Branch Circuits. A 40- or 50-ampere branch circuit shall be permitted to supply cooking appliances that are fastened in place in any occupancy. In other than dwelling units, such circuits shall be permitted to supply fixed lighting units with heavy-duty lampholders, infrared heating units, or other utilization equipment.

(D) Branch Circuits Larger Than 50 Amperes. Branch circuits larger than 50 amperes shall supply only nonlighting outlet loads.

210.24 Branch-Circuit Requirements — Summary. The requirements for circuits that have two or more outlets or receptacles, other than the receptacle circuits of 210.11(C)(1) and (C)(2), are summarized in Table 210.24. This table provides only a summary of minimum requirements. See 210.19, 210.20, and 210.21 for the specific requirements applying to branch circuits.

210.25 Common Area Branch Circuits. Branch circuits in dwelling units shall supply only loads within that dwelling unit or loads associated only with that dwelling unit. Branch circuits required for the purpose of lighting, central alarm, signal, communications, or other needs for public or common areas of a two-family or multifamily dwelling shall not be supplied from equipment that supplies an individual dwelling unit.

III. Required Outlets

210.50 General. Receptacle outlets shall be installed as specified in 210.52 and 210.63.

(A) Cord Pendants. A cord connector that is supplied by a permanently connected cord pendant shall be considered a receptacle outlet.

Table 210.24 Summary of Branch-Circuit Requirements

Circuit Rating	15 A	20 A	30 A	40 A	50 A
Conductors (min. size):					
Circuit wires ¹	14	12	10	8	6
Taps	14	14	14	12	12
Fixture wires and cords — see 240.5					
Overcurrent Protection	15 A	20 A	30 A	40 A	50 A
Outlet devices:					
Lampholders permitted	Any type	Any type	Heavy duty	Heavy duty	Heavy duty
Receptacle rating ²	15 max. A	15 or 20 A	30 A	40 or 50 A	50 A
Maximum Load	15 A	20 A	30 A	40 A	50 A
Permissible load	See 210.23(A)	See 210.23(A)	See 210.23(B)	See 210.23(C)	See 210.23(C)

¹These gauges are for copper conductors.

²For receptacle rating of cord-connected electric-discharge luminaires (lighting fixtures), see 410.30(C).

(B) Cord Connections. A receptacle outlet shall be installed wherever flexible cords with attachment plugs are used. Where flexible cords are permitted to be permanently connected, receptacles shall be permitted to be omitted for such cords.

(C) Appliance Outlets. Appliance receptacle outlets installed in a dwelling unit for specific appliances, such as laundry equipment, shall be installed within 1.8 m (6 ft) of the intended location of the appliance.

210.52 Dwelling Unit Receptacle Outlets. This section provides requirements for 125-volt, 15- and 20-ampere receptacle outlets. Receptacle outlets required by this section shall be in addition to any receptacle that is part of a luminaire (lighting fixture) or appliance, located within cabinets or cupboards, or located more than 1.7 m (5½ ft) above the floor.

Permanently installed electric baseboard heaters equipped with factory-installed receptacle outlets or outlets provided as a separate assembly by the manufacturer shall be permitted as the required outlet or outlets for the wall space utilized by such permanently installed heaters. Such receptacle outlets shall not be connected to the heater circuits.

FPN: Listed baseboard heaters include instructions that may not permit their installation below receptacle outlets.

(A) General Provisions. In every kitchen, family room, dining room, living room, parlor, library, den, sunroom, bedroom, recreation room, or similar room or area of dwelling units, receptacle outlets shall be installed in accordance with the general provisions specified in 210.52(A)(1) through (A)(3).

(1) Spacing. Receptacles shall be installed so that no point measured horizontally along the floor line in any wall space is more than 1.8 m (6 ft) from a receptacle outlet.

(2) Wall Space. As used in this section, a wall space shall include the following:

- (1) Any space 600 mm (2 ft) or more in width (including space measured around corners) and unbroken along the floor line by doorways, fireplaces, and similar openings
- (2) The space occupied by fixed panels in exterior walls, excluding sliding panels
- (3) The space afforded by fixed room dividers such as freestanding bar-type counters or railings

(3) Floor Receptacles. Receptacle outlets in floors shall not be counted as part of the required number of receptacle outlets unless located within 450 mm (18 in.) of the wall.

(B) Small Appliances.

(1) Receptacle Outlets Served. In the kitchen, pantry, breakfast room, dining room, or similar area of a dwelling unit, the two or more 20-ampere small-appliance branch circuits required by 210.11(C)(1) shall serve all wall and floor receptacle outlets covered by 210.52(A), all countertop outlets covered by 210.52(C), and receptacle outlets for refrigeration equipment.

Exception No. 1: In addition to the required receptacles specified by 210.52, switched receptacles supplied from a general-purpose branch circuit as defined in 210.70(A)(1), Exception No. 1, shall be permitted.

Exception No. 2: The receptacle outlet for refrigeration equipment shall be permitted to be supplied from an individual branch circuit rated 15 amperes or greater.

(2) No Other Outlets. The two or more small-appliance branch circuits specified in 210.52(B)(1) shall have no other outlets.

Exception No. 1: A receptacle installed solely for the electrical supply to and support of an electric clock in any of the rooms specified in 210.52(B)(1).

Exception No. 2: Receptacles installed to provide power for supplemental equipment and lighting on gas-fired ranges, ovens, or counter-mounted cooking units.

(3) Kitchen Receptacle Requirements. Receptacles installed in a kitchen to serve countertop surfaces shall be supplied by not fewer than two small-appliance branch circuits, either or both of which shall also be permitted to supply receptacle outlets in the same kitchen and in other rooms specified in 210.52(B)(1). Additional small-appliance branch circuits shall be permitted to supply receptacle outlets in the kitchen and other rooms specified in 210.52(B)(1). No small-appliance branch circuit shall serve more than one kitchen.

(C) Countertops. In kitchens and dining rooms of dwelling units, receptacle outlets for counter spaces shall be installed in accordance with 210.52(C)(1) through (C)(5).

(1) Wall Counter Spaces. A receptacle outlet shall be installed at each wall counter space that is 300 mm (12 in.) or wider. Receptacle outlets shall be installed so that no point along the wall line is more than 600 mm (24 in.) measured horizontally from a receptacle outlet in that space.

Exception: Receptacle outlets shall not be required on a wall directly behind a range or sink in the installation described in Figure 210.52.

(2) Island Counter Spaces. At least one receptacle shall be installed at each island counter space with a long dimension of 600 mm (24 in.) or greater and a short dimension of 300 mm (12 in.) or greater. Where a rangetop or sink is installed in an island counter and the width of the counter behind the rangetop or sink is less than 300 mm (12 in.), the rangetop or sink is considered to divide the island into two separate countertop spaces as defined in 210.52(C)(4).

(3) Peninsular Counter Spaces. At least one receptacle outlet shall be installed at each peninsular counter space with a long dimension of 600 mm (24 in.) or greater and a short dimension of 300 mm (12 in.) or greater. A peninsular countertop is measured from the connecting edge.

(4) Separate Spaces. Countertop spaces separated by rangetops, refrigerators, or sinks shall be considered as separate

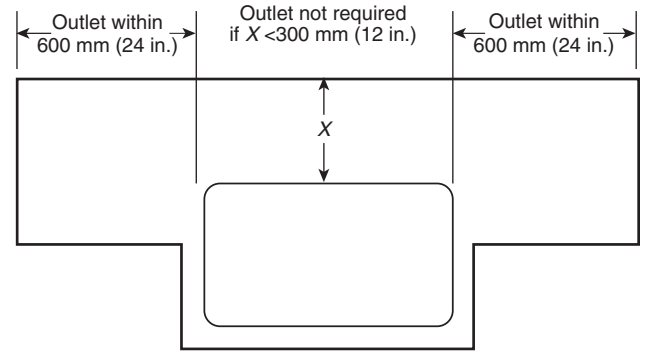

Sink or range extending from face of counter

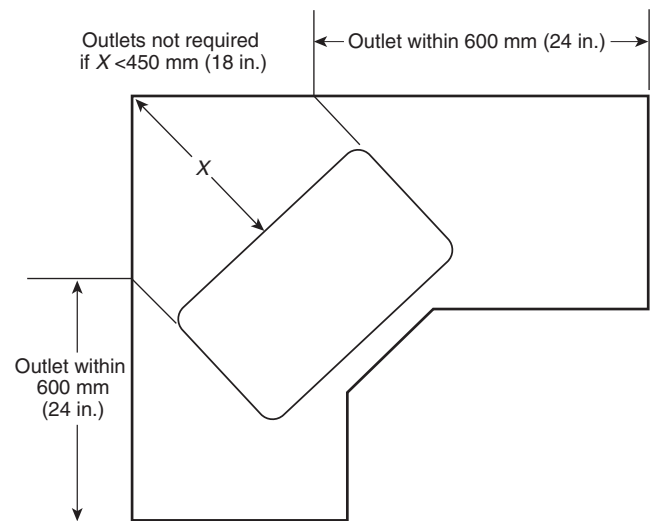

Sink or range mounted in corner

Figure 210.52 Determination of Area Behind Sink or Range.

rate countertop spaces in applying the requirements of 210.52(C)(1), (C)(2), and (C)(3).

(5) Receptacle Outlet Location. Receptacle outlets shall be located above, but not more than 500 mm (20 in.) above, the countertop. Receptacle outlets rendered not readily accessible by appliances fastened in place, appliance garages, sinks, or rangetops as covered in 210.52(C)(1), Exception, or appliances occupying dedicated space shall not be considered as these required outlets.

Exception to (5): To comply with the conditions specified in (1) or (2), receptacle outlets shall be permitted to be mounted not more than 300 mm (12 in.) below the countertop. Receptacles mounted below a countertop in accordance with this exception shall not be located where the countertop extends more than 150 mm (6 in.) beyond its support base.

- (1) *Construction for the physically impaired*
- (2) *On island and peninsular countertops where the countertop is flat across its entire surface (no backsplashes, dividers, etc.) and there are no means to mount a receptacle within 500 mm (20 in.) above the countertop, such as an overhead cabinet*

(D) Bathrooms. In dwelling units, at least one receptacle outlet shall be installed in bathrooms within 900 mm (3 ft) of the outside edge of each basin. The receptacle outlet shall be located on a wall or partition that is adjacent to the basin or basin countertop.

Exception: The receptacle shall not be required to be mounted in the wall or partition where it is installed on the side or face of the basin cabinet not more than 300 mm (12 in.) below the countertop.

(E) Outdoor Outlets. For a one-family dwelling and each unit of a two-family dwelling that is at grade level, at least one receptacle outlet accessible at grade level and not more than 2.0 m (6½ ft) above grade shall be installed at the front and back of the dwelling.

For each dwelling unit of a multifamily dwelling where the dwelling unit is located at grade level and provided with individual exterior entrance/egress, at least one receptacle outlet accessible from grade level and not more than 2.0 m (6½ ft) above grade shall be installed. See 210.8(A)(3).

(F) Laundry Areas. In dwelling units, at least one receptacle outlet shall be installed for the laundry.

Exception No. 1: In a dwelling unit that is an apartment or living area in a multifamily building where laundry facilities are provided on the premises and are available to all building occupants, a laundry receptacle shall not be required.

Exception No. 2: In other than one-family dwellings where laundry facilities are not to be installed or permitted, a laundry receptacle shall not be required.

(G) Basements and Garages. For a one-family dwelling, at least one receptacle outlet, in addition to any provided for laundry equipment, shall be installed in each basement and in each attached garage, and in each detached garage with electric power. See 210.8(A)(2) and (A)(5). Where a portion of the basement is finished into one or more habitable rooms, each separate unfinished portion shall have a receptacle outlet installed in accordance with this section.

(H) Hallways. In dwelling units, hallways of 3.0 m (10 ft) or more in length shall have at least one receptacle outlet.

As used in this subsection, the hall length shall be considered the length along the centerline of the hall without passing through a doorway.

210.63 Heating, Air-Conditioning, and Refrigeration Equipment Outlet. A 125-volt, single-phase, 15- or 20-ampere-rated receptacle outlet shall be installed at an accessible location for the servicing of heating, air-conditioning, and refrigeration equipment. The receptacle shall be located on the same level and within 7.5 m (25 ft) of the heating, air-conditioning, and refrigeration equipment. The receptacle outlet shall not be connected to the load side of the equipment disconnecting means.

Exception: A receptacle outlet shall not be required at one- and two-family dwellings for the service of evaporative coolers.

FPN: See 210.8 for ground-fault circuit-interrupter requirements.

210.70 Lighting Outlets Required. Lighting outlets shall be installed where specified in 210.70(A).

(A) Dwelling Units. In dwelling units, lighting outlets shall be installed in accordance with 210.70(A)(1), (A)(2), and (A)(3).

(1) Habitable Rooms. At least one wall switch-controlled lighting outlet shall be installed in every habitable room and bathroom.

Exception No. 1: In other than kitchens and bathrooms, one or more receptacles controlled by a wall switch shall be permitted in lieu of lighting outlets.

Exception No. 2: Lighting outlets shall be permitted to be controlled by occupancy sensors that are (1) in addition to wall switches or (2) located at a customary wall switch location and equipped with a manual override that will allow the sensor to function as a wall switch.

(2) Additional Locations. Additional lighting outlets shall be installed in accordance with (A)(2)(a), (A)(2)(b), and (A)(2)(c).

(a) At least one wall switch-controlled lighting outlet shall be installed in hallways, stairways, attached garages, and detached garages with electric power.

(b) For dwelling units, attached garages, and detached garages with electric power, at least one wall switch-controlled lighting outlet shall be installed to provide illumination on the exterior side of outdoor entrances or exits with grade level access. A vehicle door in a garage shall not be considered as an outdoor entrance or exit.

(c) Where one or more lighting outlet(s) are installed for interior stairways, there shall be a wall switch at each floor level, and landing level that includes an entryway, to control the lighting outlet(s) where the stairway between floor levels has six risers or more.

Exception to (A)(2)(a), (A)(2)(b), and (A)(2)(c): In hallways, stairways, and at outdoor entrances, remote, central, or automatic control of lighting shall be permitted.

(3) Storage or Equipment Spaces. For attics, underfloor spaces, utility rooms, and basements, at least one lighting outlet containing a switch or controlled by a wall switch shall be installed where these spaces are used for storage or contain equipment requiring servicing. At least one point of control shall be at the usual point of entry to these spaces. The lighting outlet shall be provided at or near the equipment requiring servicing.

ARTICLE 215 Feeders

215.1 Scope. This article covers the installation requirements, overcurrent protection requirements, minimum size, and ampacity of conductors for feeders supplying branch-circuit loads.

215.2 Minimum Rating and Size.

(A) Feeders Not More Than 600 Volts.

(1) General. Feeder conductors shall have an ampacity not less than required to supply the load as calculated in Parts III and IV of Article 220. The minimum feeder-circuit conductor size, before the application of any adjustment or correction factors, shall have an allowable ampacity not less than the noncontinuous load plus 125 percent of the continuous load.

Exception: Where the assembly, including the overcurrent devices protecting the feeder(s), is listed for operation at 100 percent of its rating, the allowable ampacity of the feeder conductors shall be permitted to be not less than the sum of the continuous load plus the noncontinuous load.

The size of the feeder circuit grounded conductor shall not be smaller than that required by 250.122, except that 250.122(F) shall not apply where grounded conductors are run in parallel.

Additional minimum sizes shall be as specified in 215.2(A)(2) and (A)(3) under the conditions stipulated.

(2) Ampacity Relative to Service Conductors. The feeder conductor ampacity shall not be less than that of the service conductors where the feeder conductors carry the total load supplied by service conductors with an ampacity of 55 amperes or less.

(3) Individual Dwelling Unit or Mobile Home Conductors. Feeder conductors for individual dwelling units or

mobile homes need not be larger than service conductors. Paragraph 310.15(B)(6) shall be permitted to be used for conductor size.

FPN No. 1: See Examples D1(a), D1(b), D2(a), D2(b), and D2(c) 0 in Annex D.

FPN No. 2: Conductors for feeders as defined in Article 100, sized to prevent a voltage drop exceeding 3 percent at the farthest outlet of power, heating, and lighting loads, or combinations of such loads, and where the maximum total voltage drop on both feeders and branch circuits to the farthest outlet does not exceed 5 percent, will provide reasonable efficiency of operation.

FPN No. 3: See 210.19(A), FPN No. 4, for voltage drop for branch circuits.

215.3 Overcurrent Protection. Feeders shall be protected against overcurrent in accordance with the provisions of Part I of Article 240. Where a feeder supplies continuous loads or any combination of continuous and noncontinuous loads, the rating of the overcurrent device shall not be less than the noncontinuous load plus 125 percent of the continuous load.

Exception No. 1: Where the assembly, including the overcurrent devices protecting the feeder(s), is listed for operation at 100 percent of its rating, the ampere rating of the overcurrent device shall be permitted to be not less than the sum of the continuous load plus the noncontinuous load.

215.5 Diagrams of Feeders. If required by the authority having jurisdiction, a diagram showing feeder details shall be provided prior to the installation of the feeders. Such a diagram shall show the area in square feet of the building or other structure supplied by each feeder, the total calculated load before applying demand factors, the demand factors used, the calculated load after applying demand factors, and the size and type of conductors to be used.

215.6 Feeder Conductor Grounding Means. Where a feeder supplies branch circuits in which equipment grounding conductors are required, the feeder shall include or provide a grounding means, in accordance with the provisions of 250.134, to which the equipment grounding conductors of the branch circuits shall be connected.

215.7 Ungrounded Conductors Tapped from Grounded Systems. Two-wire dc circuits and ac circuits of two or more ungrounded conductors shall be permitted to be tapped from the ungrounded conductors of circuits having a grounded neutral conductor. Switching devices in each tapped circuit shall have a pole in each ungrounded conductor.

215.9 Ground-Fault Circuit-Interrupter Protection for Personnel. Feeders supplying 15- and 20-ampere receptacle

branch circuits shall be permitted to be protected by a ground-fault circuit interrupter in lieu of the provisions for such interrupters as specified in 210.8 and 590.6(A).

215.12 Identification for Feeders.

(A) Grounded Conductor. The grounded conductor of a feeder shall be identified in accordance with 200.6.

(B) Equipment Grounding Conductor. The equipment grounding conductor shall be identified in accordance with 250.119.

**ARTICLE 220
Branch-Circuit, Feeder,
and Service Calculations**

I. General

220.1 Scope. This article provides requirements for calculating branch-circuit, feeder, and service loads. Part I provides for general requirements for calculation methods. Part II provides calculation methods for branch circuit loads. Parts III and IV provide calculation methods for feeders and services.

FPN: See Figure 220.1 for information on the organization of Article 220.

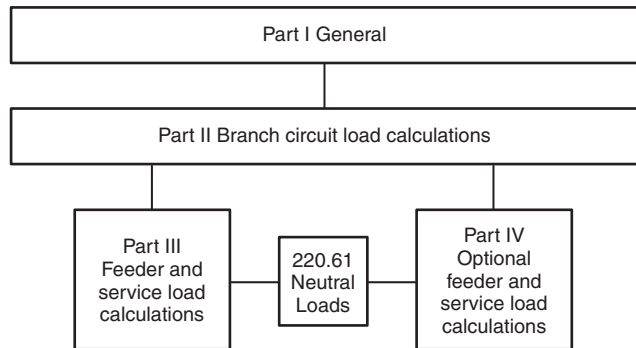

Figure 220.1 Branch-Circuit, Feeder, and Service Calculation Methods.

220.3 Application of Other Articles. In other articles applying to the calculation of loads in specialized applications, there are requirements provided in Table 220.3 that are in addition to, or modifications of, those within this article.

220.5 Calculations.

(A) Voltages. Unless other voltages are specified, for purposes of calculating branch-circuit and feeder loads, nominal

Table 220.3 Additional Load Calculation References

Calculation	Article	Section (or Part)
Air-Conditioning and Refrigerating Equipment, Branch-Circuit Conductor Sizing	440	Part IV
Fixed Electric Space Heating Equipment, Branch-Circuit Sizing	424	424.3
Storage-Type Water Heaters	422	422.11(E)

system voltages of 120, 120/240, 208Y/120, 240, 347, 480Y/277, 480, 600Y/347, and 600 volts shall be used.

(B) Fractions of an Ampere. Where calculations result in a fraction of an ampere that is less than 0.5, such fractions shall be permitted to be dropped.

II. Branch Circuit Load Calculations

220.10 General. Branch-circuit loads shall be calculated as shown in 220.12, 220.14, and 220.16.

220.12 Lighting Load for Specified Occupancies. A unit load of not less than that specified in Table 220.12 for occupancies specified therein shall constitute the minimum lighting load. The floor area for each floor shall be calculated from the outside dimensions of the building, dwelling unit, or other area involved. For dwelling units, the calculated floor area shall not include open porches, garages, or unused or unfinished spaces not adaptable for future use.

Table 220.12 General Lighting Loads by Occupancy

Type of Occupancy	Unit Load	
	Volt-Amperes per Square Meter	Volt-Amperes per Square Foot
Dwelling units ^a	33	3

^aSee 220.14(J).

FPN: The unit values herein are based on minimum load conditions and 100 percent power factor and may not provide sufficient capacity for the installation contemplated.

220.14 Other Loads — All Occupancies. In all occupancies, the minimum load for each outlet for general-use receptacles and outlets not used for general illumination shall not be less than that calculated in 220.14(A) through (E), (I), and (J), the loads shown being based on nominal branch-circuit voltages.

(A) Specific Appliances or Loads. An outlet for a specific appliance or other load not covered in 220.14(B) through

(E), (I), and (J) shall be calculated based on the ampere rating of the appliance or load served.

(B) Electric Dryers and Household Electric Cooking Appliances. Load calculations shall be permitted as specified in 220.54 for electric dryers and in 220.55 for electric ranges and other cooking appliances.

(C) Motor Loads. Outlets for motor loads shall be calculated in accordance with the requirements in 430.22 in the *NEC*, 430.24 in the *NEC*, and 440.6.

(D) Luminaires (Lighting Fixtures). An outlet supplying luminaire(s) [lighting fixture(s)] shall be calculated based on the maximum volt-ampere rating of the equipment and lamps for which the luminaire(s) [fixture(s)] is rated.

(E) Heavy-Duty Lampholders. Outlets for heavy-duty lampholders shall be calculated at a minimum of 600 volt-amperes.

(I) Receptacle Outlets. Except as covered in 220.14(J), receptacle outlets shall be calculated at not less than 180 volt-amperes for each single or for each multiple receptacle on one yoke. A single piece of equipment consisting of a multiple receptacle comprised of four or more receptacles shall be calculated at not less than 90 volt-amperes per receptacle. This provision shall not be applicable to the receptacle outlets specified in 210.11(C)(1) and (C)(2).

(J) Dwelling Occupancies. In one-family, two-family, and multifamily dwellings and in guest rooms or guest suites of hotels and motels, the outlets specified in (J)(1), (J)(2), and (J)(3) are included in the general lighting load calculations of 220.12. No additional load calculations shall be required for such outlets.

- (1) All general-use receptacle outlets of 20-ampere rating or less, including receptacles connected to the circuits in 210.11(C)(3)
- (2) The receptacle outlets specified in 210.52(E) and (G)
- (3) The lighting outlets specified in 210.70(A)

220.16 Loads for Additions to Existing Installations.

(A) Dwelling Units. Loads added to an existing dwelling unit(s) shall comply with the following as applicable:

- (1) Loads for structural additions to an existing dwelling unit or for a previously unwired portion of an existing dwelling unit, either of which exceeds 46.5 m² (500 ft²), shall be calculated in accordance with 220.12 and 220.14.
- (2) Loads for new circuits or extended circuits in previously wired dwelling units shall be calculated in accordance with either 220.12 or 220.14, as applicable.

220.18 Maximum Loads. The total load shall not exceed the rating of the branch circuit, and it shall not exceed the maximum loads specified in 220.18(A) through (C) under the conditions specified therein.

(A) Motor-Operated and Combination Loads. Where a circuit supplies only motor-operated loads, Article 430 in the *NEC* shall apply. Where a circuit supplies only air-conditioning equipment, refrigerating equipment, or both, Article 440 shall apply. For circuits supplying loads consisting of motor-operated utilization equipment that is fastened in place and has a motor larger than 1/8 hp in combination with other loads, the total calculated load shall be based on 125 percent of the largest motor load plus the sum of the other loads.

(B) Inductive Lighting Loads. For circuits supplying lighting units that have ballasts, transformers, or autotransformers, the calculated load shall be based on the total ampere ratings of such units and not on the total watts of the lamps.

(C) Range Loads. It shall be permissible to apply demand factors for range loads in accordance with Table 220.55, including Note 4.

III. Feeder and Service Load Calculations

220.40 General. The calculated load of a feeder or service shall not be less than the sum of the loads on the branch circuits supplied, as determined by Part II of this article, after any applicable demand factors permitted by Parts III or IV have been applied.

FPN: See Examples D1(a), D1(b), D2(a), D2(b), and D2(c) in Annex D. See 220.18(B) for the maximum load in amperes permitted for lighting units operating at less than 100 percent power factor.

220.42 General Lighting. The demand factors specified in Table 220.42 shall apply to that portion of the total branch-circuit load calculated for general illumination. They shall not be applied in determining the number of branch circuits for general illumination.

Table 220.42 Lighting Load Demand Factors

Type of Occupancy	Portion of Lighting Load to Which Demand Factor Applies (Volt-Amperes)	Demand Factor (Percent)
Dwelling units	First 3000 or less at	100
	From 3001 to 120,000 at	35
	Remainder over 120,000 at	25

220.50 Motors. Motor loads shall be calculated in accordance with 430.24, 430.25, and 430.26 in the *NEC* and with 440.6 for hermetic refrigerant motor compressors.

220.51 Fixed Electric Space Heating. Fixed electric space heating loads shall be calculated at 100 percent of the total connected load. However, in no case shall a feeder or service load current rating be less than the rating of the largest branch circuit supplied.

Exception: Where reduced loading of the conductors results from units operating on duty-cycle, intermittently, or from all units not operating at the same time, the authority having jurisdiction may grant permission for feeder and service conductors to have an ampacity less than 100 percent, provided the conductors have an ampacity for the load so determined.

220.52 Small Appliance and Laundry Loads — Dwelling Unit.

(A) Small Appliance Circuit Load. In each dwelling unit, the load shall be calculated at 1500 volt-amperes for each 2-wire small-appliance branch circuit required by 210.11(C)(1). Where the load is subdivided through two or more feeders, the calculated load for each shall include not less than 1500 volt-amperes for each 2-wire small-appliance branch circuit. These loads shall be permitted to be included with the general lighting load and subjected to the demand factors provided in Table 220.42.

Exception: The individual branch circuit permitted by 210.52(B)(1), Exception No. 2, shall be permitted to be excluded from the calculation required by 220.52.

(B) Laundry Circuit Load. A load of not less than 1500 volt-amperes shall be included for each 2-wire laundry branch circuit installed as required by 210.11(C)(2). This load shall be permitted to be included with the general lighting load and subjected to the demand factors provided in Table 220.42.

220.53 Appliance Load — Dwelling Unit(s). It shall be permissible to apply a demand factor of 75 percent to the nameplate rating load of four or more appliances fastened in place, other than electric ranges, clothes dryers, space-heating equipment, or air-conditioning equipment, that are served by the same feeder or service in a one-family, two-family, or multifamily dwelling.

220.54 Electric Clothes Dryers — Dwelling Unit(s). The load for household electric clothes dryers in a dwelling unit(s) shall be either 5000 watts (volt-amperes) or the nameplate rating, whichever is larger, for each dryer served.

220.55 Electric Ranges and Other Cooking Appliances — Dwelling Unit(s). The load for household electric ranges, wall-mounted ovens, counter-mounted cooking units, and other household cooking appliances individually rated in excess of 1¾ kW shall be permitted to be calculated in accordance with Table 220.55. Kilovolt-amperes (kVA) shall be considered equivalent to kilowatts (kW) for loads calculated under this section.

Where two or more single-phase ranges are supplied by a 3-phase, 4-wire feeder or service, the total load shall be calculated on the basis of twice the maximum number connected between any two phases.

FPN No. 1: See Example D5(a) in Annex D in the *NEC*.

FPN No. 3: See examples D1(a), D1(b), D2(a), D2(b), and D2(c) in Annex D.

220.60 Noncoincident Loads. Where it is unlikely that two or more noncoincident loads will be in use simultaneously, it shall be permissible to use only the largest load(s) that will be used at one time for calculating the total load of a feeder or service.

220.61 Feeder or Service Neutral Load.

(A) Basic Calculation. The feeder or service neutral load shall be the maximum unbalance of the load determined by this article. The maximum unbalanced load shall be the maximum net calculated load between the neutral and any one ungrounded conductor.

Exception: For 3-wire, 2-phase or 5-wire, 2-phase systems, the maximum unbalanced load shall be the maximum net calculated load between the neutral and any one ungrounded conductor multiplied by 140 percent.

(B) Permitted Reductions. A service or feeder supplying the following loads shall be permitted to have an additional demand factor of 70 percent applied to the amount in 220.61(B)(1) or portion of the amount in 220.61(B)(2) determined by the basic calculation:

- (1) A feeder or service supplying household electric ranges, wall-mounted ovens, counter-mounted cooking units, and electric dryers, where the maximum unbalanced load has been determined in accordance with Table 220.55 for ranges and 220.54 for dryers
- (2) That portion of the unbalanced load in excess of 200 amperes where the feeder or service is supplied from a 3-wire dc or single-phase ac system, or a 4-wire, 3-phase; 3-wire, 2-phase system, or a 5-wire, 2-phase system

(C) Prohibited Reductions. There shall be no reduction of the neutral or grounded conductor capacity applied to the

Table 220.55 Demand Factors and Loads for Household Electric Ranges, Wall-Mounted Ovens, Counter-Mounted Cooking Units, and Other Household Cooking Appliances over 1¾ kW Rating (Column C to be used in all cases except as otherwise permitted in Note 3.)

Number of Appliances	Demand Factor (Percent) (See Notes)		Column C Maximum Demand (kW) (See Notes) (Not over 12 kW Rating)
	Column A (Less than 3½ kW Rating)	Column B (3½ kW to 8¾ kW Rating)	
1	80	80	8
2	75	65	11
3	70	55	14
4	66	50	17
5	62	45	20
6	59	43	21

- Over 12 kW through 27 kW ranges all of same rating. For ranges individually rated more than 12 kW but not more than 27 kW, the maximum demand in Column C shall be increased 5 percent for each additional kilowatt of rating or major fraction thereof by which the rating of individual ranges exceeds 12 kW.
- Over 8¾ kW through 27 kW ranges of unequal ratings. For ranges individually rated more than 8¾ kW and of different ratings, but none exceeding 27 kW, an average value of rating shall be calculated by adding together the ratings of all ranges to obtain the total connected load (using 12 kW for any range rated less than 12 kW) and dividing by the total number of ranges. Then the maximum demand in Column C shall be increased 5 percent for each kilowatt or major fraction thereof by which this average value exceeds 12 kW.
- Over 1¾ kW through 8¾ kW. In lieu of the method provided in Column C, it shall be permissible to add the nameplate ratings of all household cooking appliances rated more than 1¾ kW but not more than 8¾ kW and multiply the sum by the demand factors specified in Column A or B for the given number of appliances. Where the rating of cooking appliances falls under both Column A and Column B, the demand factors for each column shall be applied to the appliances for that column, and the results added together.
- Branch-Circuit Load. It shall be permissible to calculate the branch-circuit load for one range in accordance with Table 220.55. The branch-circuit load for one wall-mounted oven or one counter-mounted cooking unit shall be the nameplate rating of the appliance. The branch-circuit load for a counter-mounted cooking unit and not more than two wall-mounted ovens, all supplied from a single branch circuit and located in the same room, shall be calculated by adding the nameplate rating of the individual appliances and treating this total as equivalent to one range.

amount in 220.61(C)(1), or portion of the amount in (C)(2), from that determined by the basic calculation:

- Any portion of a 3-wire circuit consisting of 2-phase wires and the neutral of a 4-wire, 3-phase, wye-connected system
- That portion consisting of nonlinear loads supplied from a 4-wire, wye-connected, 3-phase system

FPN No. 1: See Examples D1(a), D1(b), and D2(b) in Annex D.

IV. Optional Feeder and Service Load Calculations

220.80 General. Optional feeder and service load calculations shall be permitted in accordance with Part IV.

220.82 Dwelling Unit.

(A) Feeder and Service Load. This section applies to a dwelling unit having the total connected load served by a

single 120/240-volt or 208Y/120-volt set of 3-wire service or feeder conductors with an ampacity of 100 or greater. It shall be permissible to calculate the feeder and service loads in accordance with this section instead of the method specified in Part III of this article. The calculated load shall be the result of adding the loads from 220.82(B) and (C). Feeder and service-entrance conductors whose calculated load is determined by this optional calculation shall be permitted to have the neutral load determined by 220.61.

(B) General Loads. The general calculated load shall be not less than 100 percent of the first 10 kVA plus 40 percent of the remainder of the following loads:

- 33 volt-amperes/m² or 3 volt-amperes/ft² for general lighting and general-use receptacles. The floor area for each floor shall be calculated from the outside dimensions of the dwelling unit. The calculated floor area shall not include open porches, garages, or unused or unfinished spaces not adaptable for future use.

- (2) 1500 volt-amperes for each 2-wire, 20-ampere small-appliance branch circuit and each laundry branch circuit specified in 220.52.
- (3) The nameplate rating of all appliances that are fastened in place, permanently connected, or located to be on a specific circuit, ranges, wall-mounted ovens, counter-mounted cooking units, clothes dryers, and water heaters.
- (4) The nameplate ampere or kVA rating of all motors and of all low-power-factor loads.

(C) Heating and Air-Conditioning Load. The largest of the following six selections (load in kVA) shall be included:

- (1) 100 percent of the nameplate rating(s) of the air conditioning and cooling.
- (2) 100 percent of the nameplate rating(s) of the heating when a heat pump is used without any supplemental electric heating.
- (3) 100 percent of the nameplate ratings of electric thermal storage and other heating systems where the usual load is expected to be continuous at the full nameplate value. Systems qualifying under this selection shall not be calculated under any other selection in 220.82(C).
- (4) 100 percent of the nameplate rating(s) of the heat pump compressor and 65 percent of the supplemental electric heating for central electric space heating systems. If the heat pump compressor is prevented from operating at the same time as the supplementary heat, it does not need to be added to the supplementary heat for the total central space heating load.
- (5) 65 percent of the nameplate rating(s) of electric space heating if less than four separately controlled units.
- (6) 40 percent of the nameplate rating(s) of electric space heating if four or more separately controlled units.

220.83 Existing Dwelling Unit. This section shall be permitted to be used to determine if the existing service or feeder is of sufficient capacity to serve additional loads. Where the dwelling unit is served by a 120/240-volt or 208Y/120-volt, 3-wire service, it shall be permissible to calculate the total load in accordance with 220.83(A) or (B).

(A) Where Additional Air-Conditioning Equipment or Electric Space-Heating Equipment Is Not to Be Installed. The following formula shall be used for existing and additional new loads.

Load (kVA)	Percent of Load
First 8 kVA of load at	100
Remainder of load at	40

Load calculations shall include the following:

- (1) General lighting and general-use receptacles at 33 volt-amperes/m² or 3 volt-amperes/ft² as determined by 220.12

- (2) 1500 volt-amperes for each 2-wire, 20-ampere small-appliance branch circuit and each laundry branch circuit specified in 220.52
- (3) Household range(s), wall-mounted oven(s), and counter-mounted cooking unit(s)
- (4) All other appliances that are permanently connected, fastened in place, or connected to a dedicated circuit, at nameplate rating

(B) Where Additional Air-Conditioning Equipment or Electric Space-Heating Equipment Is to Be Installed.

The following formula shall be used for existing and additional new loads. The larger connected load of air-conditioning or space-heating, but not both, shall be used.

Load	Percent of Load
Air-conditioning equipment	100
Central electric space heating	100
Less than four separately controlled space-heating units	100
First 8 kVA of all other loads	100
Remainder of all other loads	40

Other loads shall include the following:

- (1) General lighting and general-use receptacles at 33 volt-amperes/m² or 3 volt-amperes/ft² as determined by 220.12
- (2) 1500 volt-amperes for each 2-wire, 20-ampere small-appliance branch circuit and each laundry branch circuit specified in 220.52
- (3) Household range(s), wall-mounted oven(s), and counter-mounted cooking unit(s)
- (4) All other appliances that are permanently connected, fastened in place, or connected to a dedicated circuit, including four or more separately controlled space-heating units, at nameplate rating

ARTICLE 225
Outside Branch Circuits and Feeders

225.1 Scope. This article covers requirements for outside branch circuits and feeders run on or between buildings, structures, or poles on the premises; and electric equipment and wiring for the supply of utilization equipment that is located on or attached to the outside of buildings, structures, or poles.

225.2 Other Articles. Application of other articles, including additional requirements to specific cases of equipment and conductors, is shown in Table 225.2.

Table 225.2 Other Articles

Equipment/Conductors	Article
Branch circuits	210
Class 1, Class 2, and Class 3 remote-control, signaling, and power-limited circuits	725
Communications circuits	800
Community antenna television and radio distribution systems	820
Conductors for general wiring	310
Feeders	215
Fire alarm systems	760
Fixed outdoor electric deicing and snow-melting equipment	426*
Floating buildings	553*
Grounding	250
Messenger supported wiring	396*
Mobile homes, manufactured homes, and mobile home parks	550
Open wiring on insulators	398*
Overcurrent protection	240
Services	230
Solar photovoltaic systems	690*
Swimming pools, fountains, and similar installations	680
Use and identification of grounded conductors	200

* Article is in the *NEC*.

I. General

225.3 Calculation of Loads 600 Volts, Nominal, or Less.

(A) Branch Circuits. The load on outdoor branch circuits shall be as determined by 220.10.

(B) Feeders. The load on outdoor feeders shall be as determined by Part III of Article 220.

225.4 Conductor Covering. Where within 3.0 m (10 ft) of any building or structure other than supporting poles or towers, open individual (aerial) overhead conductors shall be insulated or covered. Conductors in cables or raceways, except Type MI cable, shall be of the rubber-covered type or thermoplastic type and, in wet locations, shall comply with 310.8. Conductors for festoon lighting shall be of the rubber-covered or thermoplastic type.

Exception: Equipment grounding conductors and grounded circuit conductors shall be permitted to be bare or covered as specifically permitted elsewhere in this Code.

225.5 Size of Conductors 600 Volts, Nominal, or Less.

The ampacity of outdoor branch-circuit and feeder conductors shall be in accordance with 310.15 based on loads as determined under 220.10 and Part III of Article 220.

225.6 Conductor Size and Support.

(A) Overhead Spans. Open individual conductors shall not be smaller than the following:

- (1) For 600 volts, nominal, or less, 10 AWG copper or 8 AWG aluminum for spans up to 15 m (50 ft) in length, and 8 AWG copper or 6 AWG aluminum for a longer span unless supported by a messenger wire

(B) Festoon Lighting. Overhead conductors for festoon lighting shall not be smaller than 12 AWG unless the conductors are supported by messenger wires. In all spans exceeding 12 m (40 ft), the conductors shall be supported by messenger wire. The messenger wire shall be supported by strain insulators. Conductors or messenger wires shall not be attached to any fire escape, downspout, or plumbing equipment.

225.7 Lighting Equipment Installed Outdoors.

(A) General. For the supply of lighting equipment installed outdoors, the branch circuits shall comply with Article 210, 225.7(B), and 225.7(C) and (D) in the *NEC*.

(B) Common Neutral. The ampacity of the neutral conductor shall not be less than the maximum net computed load current between the neutral and all ungrounded conductors connected to any one phase of the circuit.

225.10 Wiring on Buildings. The installation of outside wiring on surfaces of buildings shall be permitted for circuits of not over 600 volts, nominal, as open wiring on insulators, as multiconductor cable, as Type MC cable, as Type MI cable, as messenger supported wiring, in rigid metal conduit, in intermediate metal conduit, in rigid nonmetallic conduit, in cable trays, as cablebus, in wireways, in auxiliary gutters, in electrical metallic tubing, in flexible metal conduit, in liquidtight flexible metal conduit, in liquidtight flexible non-metallic conduit, and in busways.

225.11 Circuit Exits and Entrances. Where outside branch and feeder circuits leave or enter a building, the requirements of 230.52 in the *NEC* and 230.54 shall apply.

225.12 Open-Conductor Supports. Open conductors shall be supported on glass or porcelain knobs, racks, brackets, or strain insulators.

225.14 Open-Conductor Spacings.

(A) 600 Volts, Nominal, or Less. Conductors of 600 volts, nominal, or less, shall comply with the spacings provided in Table 230.51(C) in the *NEC*.

(C) Separation from Other Circuits. Open conductors shall be separated from open conductors of other circuits or systems by not less than 100 mm (4 in.).

225.15 Supports over Buildings. Supports over a building shall be in accordance with 230.29.

225.16 Attachment to Buildings.

(A) Point of Attachment. The point of attachment to a building shall be in accordance with 230.26.

(B) Means of Attachment. The means of attachment to a building shall be in accordance with 230.27.

225.17 Masts as Supports. Where a mast is used for the support of final spans of feeders or branch circuits, it shall be of adequate strength or be supported by braces or guys to withstand safely the strain imposed by the overhead drop. Where raceway-type masts are used, all raceway fittings shall be identified for use with masts. Only the feeder or branch circuit conductors specified within this section shall be permitted to be attached to the feeder and/or branch circuit mast.

225.18 Clearance from Ground. Overhead spans of open conductors and open multiconductor cables of not over 600 volts, nominal, shall have a clearance of not less than the following:

- (1) 3.0 m (10 ft) — above finished grade, sidewalks, or from any platform or projection from which they might be reached where the voltage does not exceed 150 volts to ground and accessible to pedestrians only
- (2) 3.7 m (12 ft) — over residential property and driveways, and those commercial areas not subject to truck traffic where the voltage does not exceed 300 volts to ground
- (3) 4.5 m (15 ft) — for those areas listed in the 3.7 m (12 ft) classification where the voltage exceeds 300 volts to ground
- (4) 5.5 m (18 ft) — over public streets, alleys, roads, parking areas subject to truck traffic, driveways on other than residential property, and other land traversed by vehicles, such as cultivated, grazing, forest, and orchard

225.19 Clearances from Buildings for Conductors of Not Over 600 Volts, Nominal.

(A) Above Roofs. Overhead spans of open conductors and open multiconductor cables shall have a vertical clearance of not less than 2.5 m (8 ft) above the roof surface. The vertical clearance above the roof level shall be maintained for a distance not less than 900 mm (3 ft) in all directions from the edge of the roof.

Exception No. 1: The area above a roof surface subject to pedestrian or vehicular traffic shall have a vertical clearance from the roof surface in accordance with the clearance requirements of 225.18.

Exception No. 2: Where the voltage between conductors does not exceed 300, and the roof has a slope of 100 mm in 300 mm (4 in. in 12 in.) or greater, a reduction in clearance to 900 mm (3 ft) shall be permitted.

Exception No. 3: Where the voltage between conductors does not exceed 300, a reduction in clearance above only the overhanging portion of the roof to not less than 450 mm (18 in.) shall be permitted if (1) not more than 1.8 m (6 ft) of the conductors, 1.2 m (4 ft) horizontally, pass above the roof overhang and (2) they are terminated at a through-the-roof raceway or approved support.

Exception No. 4: The requirement for maintaining the vertical clearance 900 mm (3 ft) from the edge of the roof shall not apply to the final conductor span where the conductors are attached to the side of a building.

(B) From Nonbuilding or Nonbridge Structures. From signs, chimneys, radio and television antennas, tanks, and other nonbuilding or nonbridge structures, clearances — vertical, diagonal, and horizontal — shall not be less than 900 mm (3 ft).

(C) Horizontal Clearances. Clearances shall not be less than 900 mm (3 ft).

(D) Final Spans. Final spans of feeders or branch circuits shall comply with 225.19(D)(1), (D)(2), and (D)(3).

(1) Clearance from Windows. Final spans to the building they supply, or from which they are fed, shall be permitted to be attached to the building, but they shall be kept not less than 900 mm (3 ft) from windows that are designed to be opened, and from doors, porches, balconies, ladders, stairs, fire escapes, or similar locations.

Exception: Conductors run above the top level of a window shall be permitted to be less than the 900-mm (3-ft) requirement.

(2) Vertical Clearance. The vertical clearance of final spans above, or within 900 mm (3 ft) measured horizontally of, platforms, projections, or surfaces from which they might be reached shall be maintained in accordance with 225.18.

(3) Building Openings. The overhead branch-circuit and feeder conductors shall not be installed beneath openings through which materials may be moved, such as openings in farm and commercial buildings, and shall not be installed where they obstruct entrance to these buildings' openings.

225.20 Mechanical Protection of Conductors. Mechanical protection of conductors on buildings, structures, or poles shall be as provided for services in 230.50.

225.21 Multiconductor Cables on Exterior Surfaces of Buildings. Supports for multiconductor cables on exterior surfaces of buildings shall be as provided in 230.51.

225.22 Raceways on Exterior Surfaces of Buildings or Other Structures. Raceways on exteriors of buildings or other structures shall be arranged to drain and shall be rain-tight in wet locations.

Exception: Flexible metal conduit, where permitted in 348.12(1), shall not be required to be raintight.

225.24 Outdoor Lampholders. Where outdoor lampholders are attached as pendants, the connections to the circuit wires shall be staggered. Where such lampholders have terminals of a type that puncture the insulation and make contact with the conductors, they shall be attached only to conductors of the stranded type.

225.25 Location of Outdoor Lamps. Locations of lamps for outdoor lighting shall be below all energized conductors, transformers, or other electric utilization equipment, unless either of the following apply:

- (1) Clearances or other safeguards are provided for relamping operations.
- (2) Equipment is controlled by a disconnecting means that can be locked in the open position.

225.26 Vegetation as Support. Vegetation such as trees shall not be used for support of overhead conductor spans.

II. More Than One Building or Other Structure

225.30 Number of Supplies. Where more than one building or other structure is on the same property and under single management, each additional building or other structure that is served by a branch circuit or feeder on the load side of the service disconnecting means shall be supplied by only one feeder or branch circuit unless permitted in 225.30(A) or (D). For the purpose of this section, a multiwire branch circuit shall be considered a single circuit.

(A) Special Conditions. Additional feeders or branch circuits shall be permitted to supply the following:

- (4) Optional standby systems
- (5) Parallel power production systems

(D) Different Characteristics. Additional feeders or branch circuits shall be permitted for different voltages, frequencies, or phases or for different uses, such as control of outside lighting from multiple locations.

225.31 Disconnecting Means. Means shall be provided for disconnecting all ungrounded conductors that supply or pass through the building or structure.

225.32 Location. The disconnecting means shall be installed either inside or outside of the building or structure served or where the conductors pass through the building or structure. The disconnecting means shall be at a readily accessible location nearest the point of entrance of the conductors. For the purposes of this section, the requirements in 230.6 shall be utilized.

225.33 Maximum Number of Disconnects.

(A) General. The disconnecting means for each supply permitted by 225.30 shall consist of not more than six switches or six circuit breakers mounted in a single enclosure, in a group of separate enclosures, or in or on a switchboard. There shall be no more than six disconnects per supply grouped in any one location.

(B) Single-Pole Units. Two or three single-pole switches or breakers capable of individual operation shall be permitted on multiwire circuits, one pole for each ungrounded conductor, as one multipole disconnect, provided they are equipped with handle ties or a master handle to disconnect all ungrounded conductors with no more than six operations of the hand.

225.34 Grouping of Disconnects.

(A) General. The two to six disconnects as permitted in 225.33 shall be grouped. Each disconnect shall be marked to indicate the load served.

Exception: One of the two to six disconnecting means permitted in 225.33, where used only for a water pump also intended to provide fire protection, shall be permitted to be located remote from the other disconnecting means.

(B) Additional Disconnecting Means. The one or more additional disconnecting means for fire pumps or for emergency, legally required standby or optional standby system permitted by 225.30 shall be installed sufficiently remote from the one to six disconnecting means for normal supply to minimize the possibility of simultaneous interruption of supply.

225.35 Access to Occupants. In a multiple-occupancy building, each occupant shall have access to the occupant's supply disconnecting means.

225.36 Suitable for Service Equipment. The disconnecting means specified in 225.31 shall be suitable for use as service equipment.

Exception: For garages and outbuildings on residential property, a snap switch or a set of 3-way or 4-way snap switches shall be permitted as the disconnecting means.

225.37 Identification. Where a building or structure has any combination of feeders, branch circuits, or services passing through it or supplying it, a permanent plaque or directory shall be installed at each feeder and branch-circuit disconnect location denoting all other services, feeders, or branch circuits supplying that building or structure or passing through that building or structure and the area served by each.

Exception No. 2: This identification shall not be required for branch circuits installed from a dwelling unit to a second building or structure.

225.38 Disconnect Construction. Disconnecting means shall meet the requirements of 225.38(A) through (D).

Exception: For garages and outbuildings on residential property, snap switches or sets of 3-way or 4-way snap switches shall be permitted as the disconnecting means.

(A) Manually or Power Operable. The disconnecting means shall consist of either (1) a manually operable switch or a circuit breaker equipped with a handle or other suitable operating means or (2) a power-operable switch or circuit breaker, provided the switch or circuit breaker can be opened by hand in the event of a power failure.

(B) Simultaneous Opening of Poles. Each building or structure disconnecting means shall simultaneously disconnect all ungrounded supply conductors that it controls from the building or structure wiring system.

(C) Disconnection of Grounded Conductor. Where the building or structure disconnecting means does not disconnect the grounded conductor from the grounded conductors in the building or structure wiring, other means shall be provided for this purpose at the location of disconnecting means. A terminal or bus to which all grounded conductors can be attached by means of pressure connectors shall be permitted for this purpose.

(D) Indicating. The building or structure disconnecting means shall plainly indicate whether it is in the open or closed position.

225.39 Rating of Disconnect. The feeder or branch-circuit disconnecting means shall have a rating of not less than the load to be supplied, determined in accordance with Parts I and II of Article 220 for branch circuits, Parts III or IV of Article 220 for feeders. In no case shall the rating be lower than specified in 225.39(A), (B), (C), or (D).

(A) One-Circuit Installation. For installations to supply only limited loads of a single branch circuit, the branch

circuit disconnecting means shall have a rating of not less than 15 amperes.

(B) Two-Circuit Installations. For installations consisting of not more than two 2-wire branch circuits, the feeder or branch-circuit disconnecting means shall have a rating of not less than 30 amperes.

(C) One-Family Dwelling. For a one-family dwelling, the feeder disconnecting means shall have a rating of not less than 100 amperes, 3-wire.

(D) All Others. For all other installations, the feeder or branch-circuit disconnecting means shall have a rating of not less than 60 amperes.

ARTICLE 230 Services

230.1 Scope. This article covers service conductors and equipment for control and protection of services and their installation requirements.

FPN: See Figure 230.1.

I. General

230.2 Number of Services. A building or other structure served shall be supplied by only one service unless permitted in 230.2 (D). For the purpose of 230.40, Exception No. 2 only, underground sets of conductors, 1/0 AWG and larger, running to the same location and connected together at their supply end but not connected together at their load end shall be considered to be supplying one service.

(D) Different Characteristics. Additional services shall be permitted for different voltages, frequencies, or phases, or for different uses, such as for different rate schedules.

(E) Identification. Where a building or structure is supplied by more than one service, or any combination of branch circuits, feeders, and services, a permanent plaque or directory shall be installed at each service disconnect location denoting all other services, feeders, and branch circuits supplying that building or structure and the area served by each. See 225.37.

230.3 One Building or Other Structure Not to Be Supplied Through Another. Service conductors supplying a building or other structure shall not pass through the interior of another building or other structure.

230.6 Conductors Considered Outside the Building. Conductors shall be considered outside of a building or other structure under any of the following conditions:

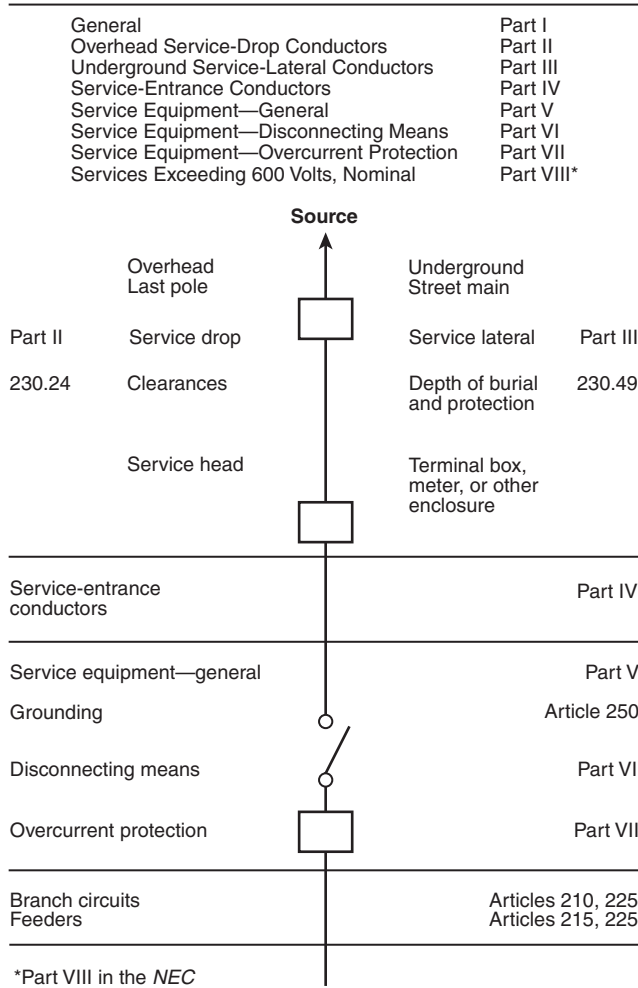

Figure 230.1 Services.

- (1) Where installed under not less than 50 mm (2 in.) of concrete beneath a building or other structure
- (2) Where installed within a building or other structure in a raceway that is encased in concrete or brick not less than 50 mm (2 in.) thick
- (3) Where installed in any vault that meets the construction requirements of Article 450, Part III in the NEC
- (4) Where installed in conduit and under not less than 450 mm (18 in.) of earth beneath a building or other structure

230.7 Other Conductors in Raceway or Cable. Conductors other than service conductors shall not be installed in the same service raceway or service cable.

Exception No. 1: Grounding conductors and bonding jumpers.

Exception No. 2: Load management control conductors having overcurrent protection.

230.8 Raceway Seal. Where a service raceway enters a building or structure from an underground distribution system, it shall be sealed in accordance with 300.5(G). Spare or unused raceways shall also be sealed. Sealants shall be identified for use with the cable insulation, shield, or other components.

230.9 Clearances on Buildings. Service conductors and final spans shall comply with 230.9(A) and (B).

(A) Clearances. Service conductors installed as open conductors or multiconductor cable without an overall outer jacket shall have a clearance of not less than 900 mm (3 ft) from windows that are designed to be opened, doors, porches, balconies, ladders, stairs, fire escapes, or similar locations.

Exception: Conductors run above the top level of a window shall be permitted to be less than the 900-mm (3-ft) requirement.

(B) Vertical Clearance. The vertical clearance of final spans above, or within 900 mm (3 ft) measured horizontally of, platforms, projections, or surfaces from which they might be reached shall be maintained in accordance with 230.24(B).

230.10 Vegetation as Support. Vegetation such as trees shall not be used for support of overhead service conductors.

II. Overhead Service-Drop Conductors

230.22 Insulation or Covering. Individual conductors shall be insulated or covered.

Exception: The grounded conductor of a multiconductor cable shall be permitted to be bare.

230.23 Size and Rating.

(A) General. Conductors shall have sufficient ampacity to carry the current for the load as calculated in accordance with Article 220 and shall have adequate mechanical strength.

(B) Minimum Size. The conductors shall not be smaller than 8 AWG copper or 6 AWG aluminum or copper-clad aluminum.

Exception: Conductors supplying only limited loads of a single branch circuit — such as small polyphase power, controlled water heaters, and similar loads — shall not be smaller than 12 AWG hard-drawn copper or equivalent.

(C) Grounded Conductors. The grounded conductor shall not be less than the minimum size as required by 250.24(C).

230.24 Clearances. Service-drop conductors shall not be readily accessible and shall comply with 230.24(A) through (D) for services not over 600 volts, nominal.

(A) Above Roofs. Conductors shall have a vertical clearance of not less than 2.5 m (8 ft) above the roof surface. The vertical clearance above the roof level shall be maintained for a distance of not less than 900 mm (3 ft) in all directions from the edge of the roof.

Exception No. 1: The area above a roof surface subject to pedestrian or vehicular traffic shall have a vertical clearance from the roof surface in accordance with the clearance requirements of 230.24(B).

Exception No. 2: Where the voltage between conductors does not exceed 300 and the roof has a slope of 100 mm in 300 mm (4 in. in 12 in.) or greater, a reduction in clearance to 900 mm (3 ft) shall be permitted.

Exception No. 3: Where the voltage between conductors does not exceed 300, a reduction in clearance above only the overhanging portion of the roof to not less than 450 mm (18 in.) shall be permitted if (1) not more than 1.8 m (6 ft) of service-drop conductors, 1.2 m (4 ft) horizontally, pass above the roof overhang, and (2) they are terminated at a through-the-roof raceway or approved support.

FPN: See 230.28 for mast supports.

Exception No. 4: The requirement for maintaining the vertical clearance 900 mm (3 ft) from the edge of the roof shall not apply to the final conductor span where the service drop is attached to the side of a building.

(B) Vertical Clearance from Ground. Service-drop conductors, where not in excess of 600 volts, nominal, shall have the following minimum clearance from final grade:

- (1) 3.0 m (10 ft) — at the electric service entrance to buildings, also at the lowest point of the drip loop of the building electric entrance, and above areas or sidewalks accessible only to pedestrians, measured from final grade or other accessible surface only for service-drop cables supported on and cabled together with a grounded bare messenger where the voltage does not exceed 150 volts to ground
- (2) 3.7 m (12 ft) — over residential property and driveways, and those commercial areas not subject to truck traffic where the voltage does not exceed 300 volts to ground
- (3) 4.5 m (15 ft) — for those areas listed in the 3.7-m (12-ft) classification where the voltage exceeds 300 volts to ground
- (4) 5.5 m (18 ft) — over public streets, alleys, roads, parking areas subject to truck traffic, driveways on other than residential property, and other land such as cultivated, grazing, forest, and orchard

(C) Clearance from Building Openings. See 230.9.

(D) Clearance from Swimming Pools. See 680.8.

230.26 Point of Attachment. The point of attachment of the service-drop conductors to a building or other structure shall provide the minimum clearances as specified in 230.9 and 230.24. In no case shall this point of attachment be less than 3.0 m (10 ft) above finished grade.

230.27 Means of Attachment. Multiconductor cables used for service drops shall be attached to buildings or other structures by fittings identified for use with service conductors. Open conductors shall be attached to fittings identified for use with service conductors or to noncombustible, nonabsorbent insulators securely attached to the building or other structure.

230.28 Service Masts as Supports. Where a service mast is used for the support of service-drop conductors, it shall be of adequate strength or be supported by braces or guys to withstand safely the strain imposed by the service drop. Where raceway-type service masts are used, all raceway fittings shall be identified for use with service masts. Only power service-drop conductors shall be permitted to be attached to a service mast.

230.29 Supports over Buildings. Service-drop conductors passing over a roof shall be securely supported by substantial structures. Where practicable, such supports shall be independent of the building.

III. Underground Service-Lateral Conductors

230.30 Insulation. Service-lateral conductors shall be insulated for the applied voltage.

Exception: A grounded conductor shall be permitted to be uninsulated as follows:

- (1) Bare copper used in a raceway.
- (2) Bare copper for direct burial where bare copper is judged to be suitable for the soil conditions.
- (3) Bare copper for direct burial without regard to soil conditions where part of a cable assembly identified for underground use.
- (4) Aluminum or copper-clad aluminum without individual insulation or covering where part of a cable assembly identified for underground use in a raceway or for direct burial.

230.31 Size and Rating.

(A) General. Service-lateral conductors shall have sufficient ampacity to carry the current for the load as calculated

in accordance with Article 220 and shall have adequate mechanical strength.

(B) Minimum Size. The conductors shall not be smaller than 8 AWG copper or 6 AWG aluminum or copper-clad aluminum.

Exception: Conductors supplying only limited loads of a single branch circuit — such as small polyphase power, controlled water heaters, and similar loads — shall not be smaller than 12 AWG copper or 10 AWG aluminum or copper-clad aluminum.

(C) Grounded Conductors. The grounded conductor shall not be less than the minimum size required by 250.24(C).

230.32 Protection Against Damage. Underground service-lateral conductors shall be protected against damage in accordance with 300.5. Service-lateral conductors entering a building shall be installed in accordance with 230.6 or protected by a raceway wiring method identified in 230.43.

230.33 Spliced Conductors. Service-lateral conductors shall be permitted to be spliced or tapped in accordance with 110.14, 300.5(E), 300.13, and 300.15.

IV. Service-Entrance Conductors

230.40 Number of Service-Entrance Conductor Sets. Each service drop or lateral shall supply only one set of service-entrance conductors.

Exception No. 1: A building shall be permitted to have one set of service-entrance conductors for each service, as defined in 230.2, run to each occupancy or group of occupancies.

Exception No. 2: Where two to six service disconnecting means in separate enclosures are grouped at one location and supply separate loads from one service drop or lateral, one set of service-entrance conductors shall be permitted to supply each or several such service equipment enclosures.

Exception No. 3: A single-family dwelling unit and a separate structure shall be permitted to have one set of service-entrance conductors run to each from a single service drop or lateral.

Exception No. 4: A two-family dwelling or a multifamily dwelling shall be permitted to have one set of service-entrance conductors installed to supply the circuits covered in 210.25.

Exception No. 5: One set of service-entrance conductors connected to the supply side of the normal service disconnecting means shall be permitted to supply each or several systems covered by 230.82(5) or 230.82(6).

230.41 Insulation of Service-Entrance Conductors. Service-entrance conductors entering or on the exterior of buildings or other structures shall be insulated.

Exception: A grounded conductor shall be permitted to be uninsulated as follows:

- (1) Bare copper used in a raceway or part of a service cable assembly.
- (2) Bare copper for direct burial where bare copper is judged to be suitable for the soil conditions.
- (3) Bare copper for direct burial without regard to soil conditions where part of a cable assembly identified for underground use.
- (4) Aluminum or copper-clad aluminum without individual insulation or covering where part of a cable assembly or identified for underground use in a raceway, or for direct burial.
- (5) Bare conductors used in an auxiliary gutter.

230.42 Minimum Size and Rating.

(A) General. The ampacity of the service-entrance conductors before the application of any adjustment or correction factors shall not be less than either (A)(1) or (A)(2). Loads shall be determined in accordance with Article 220. Ampacity shall be determined from 310.15. The maximum allowable current of busways shall be that value for which the busway has been listed or labeled.

- (1) The sum of the noncontinuous loads plus 125 percent of continuous loads
- (2) The sum of the noncontinuous load plus the continuous load if the service-entrance conductors terminate in an overcurrent device where both the overcurrent device and its assembly are listed for operation at 100 percent of their rating

(B) Specific Installations. In addition to the requirements of 230.42(A), the minimum ampacity for ungrounded conductors for specific installations shall not be less than the rating of the service disconnecting means specified in 230.79(C) and (D).

(C) Grounded Conductors. The grounded conductor shall not be less than the minimum size as required by 250.24(C).

230.43 Wiring Methods for 600 Volts, Nominal, or Less. Service-entrance conductors shall be installed in accordance with the applicable requirements of this Code covering the type of wiring method used and shall be limited to the following methods:

- (1) Open wiring on insulators
- (2) Type IGS cable
- (3) Rigid metal conduit

- (4) Intermediate metal conduit
- (5) Electrical metallic tubing
- (6) Electrical nonmetallic tubing (ENT)
- (7) Service-entrance cables
- (8) Wireways
- (9) Busways
- (10) Auxiliary gutters
- (11) Rigid nonmetallic conduit
- (12) Cablebus
- (13) Type MC cable
- (14) Mineral-insulated, metal-sheathed cable
- (15) Flexible metal conduit not over 1.8 m (6 ft) long or liquidtight flexible metal conduit not over 1.8 m (6 ft) long between raceways, or between raceway and service equipment, with equipment bonding jumper routed with the flexible metal conduit or the liquidtight flexible metal conduit according to the provisions of 250.102(A), (B), (C), and (E)
- (16) Liquidtight flexible nonmetallic conduit

230.46 Spliced Conductors. Service-entrance conductors shall be permitted to be spliced or tapped in accordance with 110.14, 300.5(E), 300.13, and 300.15.

230.49 Protection Against Physical Damage — Underground. Underground service-entrance conductors shall be protected against physical damage in accordance with 300.5.

230.50 Protection of Open Conductors and Cables Against Damage — Above Ground. Service-entrance conductors installed above ground shall be protected against physical damage as specified in 230.50(A) or (B).

(A) Service Cables. Service cables, where subject to physical damage, shall be protected by any of the following:

- (1) Rigid metal conduit
- (2) Intermediate metal conduit
- (3) Schedule 80 rigid nonmetallic conduit
- (4) Electrical metallic tubing
- (5) Other approved means

(B) Other Than Service Cable. Individual open conductors and cables other than service cables shall not be installed within 3.0 m (10 ft) of grade level or where exposed to physical damage.

Exception: Type MI and Type MC cable shall be permitted within 3.0 m (10 ft) of grade level where not exposed to physical damage or where protected in accordance with 300.5(D).

230.51 Mounting Supports. Cables or individual open service conductors shall be supported as specified in 230.51(A) or (B).

(A) Service Cables. Service cables shall be supported by straps or other approved means within 300 mm (12 in.) of every service head, gooseneck, or connection to a raceway or enclosure and at intervals not exceeding 750 mm (30 in.).

(B) Other Cables. Cables that are not approved for mounting in contact with a building or other structure shall be mounted on insulating supports installed at intervals not exceeding 4.5 m (15 ft) and in a manner that maintains a clearance of not less than 50 mm (2 in.) from the surface over which they pass.

230.53 Raceways to Drain. Where exposed to the weather, raceways enclosing service-entrance conductors shall be raintight and arranged to drain. Where embedded in masonry, raceways shall be arranged to drain.

Exception: As permitted in 348.12(1).

230.54 Overhead Service Locations.

(A) Raintight Service Head. Service raceways shall be equipped with a raintight service head at the point of connection to service-drop conductors.

(B) Service Cable Equipped with Raintight Service Head or Gooseneck. Service cables shall be equipped with a raintight service head.

Exception: Type SE cable shall be permitted to be formed in a gooseneck and taped with a self-sealing weather-resistant thermoplastic.

(C) Service Heads and Goosenecks Above Service-Drop Attachment. Service heads and goosenecks in service-entrance cables shall be located above the point of attachment of the service-drop conductors to the building or other structure.

Exception: Where it is impracticable to locate the service head or gooseneck above the point of attachment, the service head or gooseneck location shall be permitted not farther than 600 mm (24 in.) from the point of attachment.

(D) Secured. Service cables shall be held securely in place.

(E) Separately Bushed Openings. Service heads shall have conductors of different potential brought out through separately bushed openings.

Exception: For jacketed multiconductor service cable without splice.

(F) Drip Loops. Drip loops shall be formed on individual conductors. To prevent the entrance of moisture, service-entrance conductors shall be connected to the service-drop conductors either (1) below the level of the service head or

(2) below the level of the termination of the service-entrance cable sheath.

(G) Arranged That Water Will Not Enter Service Raceway or Equipment. Service-drop conductors and service-entrance conductors shall be arranged so that water will not enter service raceway or equipment.

V. Service Equipment — General

230.62 Service Equipment — Enclosed or Guarded. Energized parts of service equipment shall be enclosed as specified in 230.62(A) or guarded as specified in 230.62(B).

(A) Enclosed. Energized parts shall be enclosed so that they will not be exposed to accidental contact or shall be guarded as in 230.62(B).

(B) Guarded. Energized parts that are not enclosed shall be installed on a switchboard, panelboard, or control board and guarded in accordance with 110.18 and 110.27. Where energized parts are guarded as provided in 110.27(A)(1) and (A)(2), a means for locking or sealing doors providing access to energized parts shall be provided.

230.66 Marking. Service equipment rated at 600 volts or less shall be marked to identify it as being suitable for use as service equipment. Individual meter socket enclosures shall not be considered service equipment.

VI. Service Equipment — Disconnecting Means

230.70 General. Means shall be provided to disconnect all conductors in a building or other structure from the service-entrance conductors.

(A) Location. The service disconnecting means shall be installed in accordance with 230.70(A)(1), (A)(2), and (A)(3).

(1) Readily Accessible Location. The service disconnecting means shall be installed at a readily accessible location either outside of a building or structure or inside nearest the point of entrance of the service conductors.

(2) Bathrooms. Service disconnecting means shall not be installed in bathrooms.

(3) Remote Control. Where a remote control device(s) is used to actuate the service disconnecting means, the service disconnecting means shall be located in accordance with 230.70(A)(1).

(B) Marking. Each service disconnect shall be permanently marked to identify it as a service disconnect.

(C) Suitable for Use. Each service disconnecting means shall be suitable for the prevailing conditions.

230.71 Maximum Number of Disconnects.

(A) General. The service disconnecting means for each service permitted by 230.2, or for each set of service-entrance conductors permitted by 230.40, Exception Nos. 1, 3, 4, or 5, shall consist of not more than six switches or sets of circuit breakers, or a combination of not more than six switches and sets of circuit breakers, mounted in a single enclosure, in a group of separate enclosures, or in or on a switchboard. There shall be not more than six sets of disconnects per service grouped in any one location. For the purpose of this section, disconnecting means used solely for power monitoring equipment, transient voltage surge suppressors, or the control circuit of the ground-fault protection system or power-operable service disconnecting means, installed as part of the listed equipment, shall not be considered a service disconnecting means.

(B) Single-Pole Units. Two or three single-pole switches or breakers, capable of individual operation, shall be permitted on multiwire circuits, one pole for each ungrounded conductor, as one multipole disconnect, provided they are equipped with handle ties or a master handle to disconnect all conductors of the service with no more than six operations of the hand.

FPN: See 408.36(A) for service equipment in panelboards.

230.72 Grouping of Disconnects.

(A) General. The two to six disconnects as permitted in 230.71 shall be grouped. Each disconnect shall be marked to indicate the load served.

Exception: One of the two to six service disconnecting means permitted in 230.71, where used only for a water pump also intended to provide fire protection, shall be permitted to be located remote from the other disconnecting means.

(B) Additional Service Disconnecting Means. The one or more additional service disconnecting means for fire pumps, emergency systems, legally required standby, or optional standby services permitted by 230.2 shall be installed remote from the one to six service disconnecting means for normal service to minimize the possibility of simultaneous interruption of supply.

(C) Access to Occupants. In a multiple-occupancy building, each occupant shall have access to the occupant's service disconnecting means.

230.74 Simultaneous Opening of Poles. Each service disconnect shall simultaneously disconnect all ungrounded

service conductors that it controls from the premises wiring system.

230.75 Disconnection of Grounded Conductor. Where the service disconnecting means does not disconnect the grounded conductor from the premises wiring, other means shall be provided for this purpose in the service equipment. A terminal or bus to which all grounded conductors can be attached by means of pressure connectors shall be permitted for this purpose. In a multisection switchboard, disconnects for the grounded conductor shall be permitted to be in any section of the switchboard, provided any such switchboard section is marked.

230.76 Manually or Power Operable. The service disconnecting means for ungrounded service conductors shall consist of one of the following:

- (1) A manually operable switch or circuit breaker equipped with a handle or other suitable operating means
- (2) A power-operated switch or circuit breaker, provided the switch or circuit breaker can be opened by hand in the event of a power supply failure

230.77 Indicating. The service disconnecting means shall plainly indicate whether it is in the open or closed position.

230.79 Rating of Service Disconnecting Means. The service disconnecting means shall have a rating not less than the load to be carried, determined in accordance with Article 220. In no case shall the rating be lower than specified in 230.79 (C) or (D).

(C) One-Family Dwelling. For a one-family dwelling, the service disconnecting means shall have a rating of not less than 100 amperes, 3-wire.

(D) All Others. For all other installations, the service disconnecting means shall have a rating of not less than 60 amperes.

230.80 Combined Rating of Disconnects. Where the service disconnecting means consists of more than one switch or circuit breaker, as permitted by 230.71, the combined ratings of all the switches or circuit breakers used shall not be less than the rating required by 230.79.

230.81 Connection to Terminals. The service conductors shall be connected to the service disconnecting means by pressure connectors, clamps, or other approved means. Connections that depend on solder shall not be used.

230.82 Equipment Connected to the Supply Side of Service Disconnect. Only the following equipment shall be

permitted to be connected to the supply side of the service disconnecting means:

- (1) Cable limiters or other current-limiting devices
- (2) Meters and meter sockets nominally rated not in excess of 600 volts, provided all metal housings and service enclosures are grounded
- (3) Meter disconnect switches nominally rated not in excess of 600 volts that have a short-circuit current rating equal to or greater than the available short circuit current, provided all metal housings and service enclosures are grounded
- (5) Taps used only to supply load management devices, circuits for standby power systems, fire pump equipment, and fire and sprinkler alarms, if provided with service equipment and installed in accordance with requirements for service-entrance conductors
- (6) Solar photovoltaic systems, fuel cell systems, or interconnected electric power production sources

VII. Service Equipment — Overcurrent Protection

230.90 Where Required. Each ungrounded service conductor shall have overload protection.

(A) Ungrounded Conductor. Such protection shall be provided by an overcurrent device in series with each ungrounded service conductor that has a rating or setting not higher than the allowable ampacity of the conductor. A set of fuses shall be considered all the fuses required to protect all the ungrounded conductors of a circuit. Single-pole circuit breakers, grouped in accordance with 230.71(B), shall be considered as one protective device.

Exception No. 1: For motor-starting currents, ratings that conform with 430.52, 430.62, and 430.63 in the NEC shall be permitted.

Exception No. 2: Fuses and circuit breakers with a rating or setting that conforms with 240.4(B) or (C) and 240.6 in the NEC shall be permitted.

Exception No. 3: Two to six circuit breakers or sets of fuses shall be permitted as the overcurrent device to provide the overload protection. The sum of the ratings of the circuit breakers or fuses shall be permitted to exceed the ampacity of the service conductors, provided the calculated load does not exceed the ampacity of the service conductors.

Exception No. 5: Overload protection for 120/240-volt, 3-wire, single-phase dwelling services shall be permitted in accordance with the requirements of 310.15(B)(6).

(B) Not in Grounded Conductor. No overcurrent device shall be inserted in a grounded service conductor except a circuit breaker that simultaneously opens all conductors of the circuit.

230.91 Location. The service overcurrent device shall be an integral part of the service disconnecting means or shall be located immediately adjacent thereto.

230.93 Protection of Specific Circuits. Where necessary to prevent tampering, an automatic overcurrent device that protects service conductors supplying only a specific load, such as a water heater, shall be permitted to be locked or sealed where located so as to be accessible.

230.94 Relative Location of Overcurrent Device and Other Service Equipment. The overcurrent device shall protect all circuits and devices.

Exception No. 1: The service switch shall be permitted on the supply side.

Exception No. 2: High-impedance shunt circuits, surge arresters, surge-protective capacitors, and instrument transformers (current and voltage) shall be permitted to be connected and installed on the supply side of the service disconnecting means as permitted in 230.82.

Exception No. 4: Circuits used only for the operation of fire alarm, other protective signaling systems, or the supply to fire pump equipment shall be permitted to be connected on the supply side of the service overcurrent device where separately provided with overcurrent protection.

Exception No. 5: Meters nominally rated not in excess of 600 volts shall be permitted, provided all metal housings and service enclosures are grounded.

ARTICLE 240 Overcurrent Protection

I. General

240.1 Scope. Parts I through V of this article provide the general requirements for overcurrent protection and overcurrent protective devices not more than 600 volts, nominal.

FPN: Overcurrent protection for conductors and equipment is provided to open the circuit if the current reaches a value that will cause an excessive or dangerous temperature in conductors or conductor insulation. See also 110.9 for requirements for interrupting ratings and 110.10 for requirements for protection against fault currents.

240.2 Definition.

Tap Conductors. As used in this article, a tap conductor is defined as a conductor, other than a service conductor, that has overcurrent protection ahead of its point of supply

that exceeds the value permitted for similar conductors that are protected as described elsewhere in 240.4.

240.3 Other Articles. Equipment shall be protected against overcurrent in accordance with the article in this Code that covers the type of equipment specified in Table 240.3.

Table 240.3 Other Articles

Equipment	Article
Air-conditioning and refrigerating equipment	440
Appliances	422
Branch circuits	210
Class 1, Class 2, and Class 3 remote-control, signaling, and power-limited circuits	725
Fire alarm systems	760
Generators	445 in the NEC
Luminaires (lighting fixtures), lampholders, and lamps	410
Receptacles	406
Services	230
Solar photovoltaic systems	690 in the NEC
Switchboards and panelboards	408

240.4 Protection of Conductors. Conductors, other than flexible cords, flexible cables, and fixture wires, shall be protected against overcurrent in accordance with their ampacities specified in 310.15, unless otherwise permitted or required in 240.4 (B), (C), (D), (E), and (G).

(B) Devices Rated 800 Amperes or Less. The next higher standard overcurrent device rating (above the ampacity of the conductors being protected) shall be permitted to be used, provided all of the following conditions are met:

- (1) The conductors being protected are not part of a multioutlet branch circuit supplying receptacles for cord-and-plug-connected portable loads.
- (2) The ampacity of the conductors does not correspond with the standard ampere rating of a fuse or a circuit breaker without overload trip adjustments above its rating (but that shall be permitted to have other trip or rating adjustments).
- (3) The next higher standard rating selected does not exceed 800 amperes.

(C) Devices Rated Over 800 Amperes. Where the overcurrent device is rated over 800 amperes, the ampacity of the conductors it protects shall be equal to or greater than the rating of the overcurrent device defined in 240.6 in the NEC.

(D) Small Conductors. Unless specifically permitted in 240.4(E) or 240.4(G), the overcurrent protection shall not exceed 15 amperes for 14 AWG, 20 amperes for 12 AWG, and 30 amperes for 10 AWG copper; or 15 amperes for 12 AWG and 25 amperes for 10 AWG aluminum and copper-clad aluminum after any correction factors for ambient temperature and number of conductors have been applied.

(E) Tap Conductors. Tap conductors shall be permitted to be protected against overcurrent in accordance with the following:

- (1) 210.19(A)(3) and (A)(4) Household Ranges and Cooking Appliances and Other Loads
- (2) 240.5(B)(2) Fixture Wire*
- (3) 240.21 Location in Circuit*
- (4) 368.17(B) Reduction in Ampacity Size of Busway*
- (5) 368.17(C) Feeder or Branch Circuits (busway taps)*
- (6) 430.53(D) Single Motor Taps*

* Section is in the *NEC*

(G) Overcurrent Protection for Specific Conductor Applications. Overcurrent protection for the specific conductors shall be permitted to be provided as referenced in Table 240.4(G).

Table 240.4(G) Specific Conductor Applications

Conductor	Article	Section
Air-conditioning and refrigeration equipment circuit conductors	440, Parts III, VI	
Motor-operated appliance circuit conductors	422, Part II	
Remote-control, signaling, and power-limited circuit conductors	725	725.23, 725.24, 725.41, and Chapter 9, Tables 11(A) and 11(B) in the <i>NEC</i>

II. Location

240.20 Ungrounded Conductors.

(A) Overcurrent Device Required. A fuse or an overcurrent trip unit of a circuit breaker shall be connected in series with each ungrounded conductor. A combination of a current transformer and overcurrent relay shall be considered equivalent to an overcurrent trip unit.

FPN: For motor circuits, see Parts III, IV, V, and XI of Article 430 in the *NEC*.

(B) Circuit Breaker as Overcurrent Device. Circuit breakers shall open all ungrounded conductors of the circuit

both manually and automatically unless otherwise permitted in 240.20(B)(1), (B)(2), and (B)(3).

(1) Multiwire Branch Circuit. Except where limited by 210.4(B), individual single-pole circuit breakers, with or without identified handle ties, shall be permitted as the protection for each ungrounded conductor of multiwire branch circuits that serve only single-phase line-to-neutral loads.

(2) Grounded Single-Phase and 3-Wire dc Circuits. In grounded systems, individual single-pole circuit breakers with identified handle ties shall be permitted as the protection for each ungrounded conductor for line-to-line connected loads for single-phase circuits or 3-wire, direct-current circuits.

(3) 3-Phase and 2-Phase Systems. For line-to-line loads in 4-wire, 3-phase systems or 5-wire, 2-phase systems having a grounded neutral and no conductor operating at a voltage greater than permitted in 210.6, individual single-pole circuit breakers with identified handle ties shall be permitted as the protection for each ungrounded conductor.

240.21 Location in Circuit. Overcurrent protection shall be provided in each ungrounded circuit conductor and shall be located at the point where the conductors receive their supply except as specified in 240.21(A) and (D).. No conductor supplied under the provisions of 240.21(A) and (D) shall supply another conductor under those provisions, except through an overcurrent protective device meeting the requirements of 240.4.

(A) Branch-Circuit Conductors. Branch-circuit tap conductors meeting the requirements specified in 210.19 shall be permitted to have overcurrent protection located as specified in that section.

(D) Service Conductors. Service-entrance conductors shall be permitted to be protected by overcurrent devices in accordance with 230.91.

240.22 Grounded Conductor. No overcurrent device shall be connected in series with any conductor that is intentionally grounded, unless one of the following two conditions is met:

- (1) The overcurrent device opens all conductors of the circuit, including the grounded conductor, and is designed so that no pole can operate independently.

240.23 Change in Size of Grounded Conductor. Where a change occurs in the size of the ungrounded conductor, a similar change shall be permitted to be made in the size of the grounded conductor.

240.24 Location in or on Premises.

(A) Accessibility. Overcurrent devices shall be readily accessible and shall be installed so that the center of the grip

of the operating handle of the switch or circuit breaker, when in its highest position, is not more than 2.0 m (6 ft 7 in.) above the floor or working platform unless the following applies:

- (4) For overcurrent devices adjacent to utilization equipment that they supply, access shall be permitted to be by portable means.

(B) Occupancy. Each occupant shall have ready access to all overcurrent devices protecting the conductors supplying that occupancy.

(C) Not Exposed to Physical Damage. Overcurrent devices shall be located where they will not be exposed to physical damage.

FPN: See 110.11, Deteriorating Agents.

(D) Not in Vicinity of Easily Ignitable Material. Overcurrent devices shall not be located in the vicinity of easily ignitable material, such as in clothes closets.

(E) Not Located in Bathrooms. In dwelling units and guest rooms or guest suites of hotels and motels, overcurrent devices, other than supplementary overcurrent protection, shall not be located in bathrooms.

III. Enclosures

240.30 General.

(A) Protection from Physical Damage. Overcurrent devices shall be protected from physical damage by the following:

- (1) Installation in enclosures, cabinets, cutout boxes, or equipment assemblies

(B) Operating Handle. The operating handle of a circuit breaker shall be permitted to be accessible without opening a door or cover.

240.32 Damp or Wet Locations. Enclosures for overcurrent devices in damp or wet locations shall comply with 312.2(A).

240.33 Vertical Position. Enclosures for overcurrent devices shall be mounted in a vertical position unless that is shown to be impracticable. Circuit breaker enclosures shall be permitted to be installed horizontally where the circuit breaker is installed in accordance with 240.81 in the *NEC*. Listed busway plug-in units shall be permitted to be mounted in orientations corresponding to the busway mounting position.

V. Plug Fuses, Fuseholders, and Adapters

240.50 General.

(A) Maximum Voltage. Plug fuses shall be permitted to be used in the following circuits:

- (1) Circuits not exceeding 125 volts between conductors
- (2) Circuits supplied by a system having a grounded neutral where the line-to-neutral voltage does not exceed 150 volts

(E) Screw Shell. The screw shell of a plug-type fuseholder shall be connected to the load side of the circuit.

240.52 Edison-Base Fuseholders. Fuseholders of the Edison-base type shall be installed only where they are made to accept Type S fuses by the use of adapters.

ARTICLE 250 Grounding and Bonding

I. General

250.1 Scope. This article covers general requirements for grounding and bonding of electrical installations, and specific requirements in (1) through (6).

- (1) Systems, circuits, and equipment required, permitted, or not permitted to be grounded
- (2) Circuit conductor to be grounded on grounded systems
- (3) Location of grounding connections
- (4) Types and sizes of grounding and bonding conductors and electrodes
- (5) Methods of grounding and bonding
- (6) Conditions under which guards, isolation, or insulation may be substituted for grounding

250.2 Definitions.

Effective Ground-Fault Current Path. An intentionally constructed, permanent, low-impedance electrically conductive path designed and intended to carry current under ground-fault conditions from the point of a ground fault on a wiring system to the electrical supply source and that facilitates the operation of the overcurrent protective device or ground fault detectors on high-impedance grounded systems.

Ground Fault. An unintentional, electrically conducting connection between an ungrounded conductor of an electrical circuit and the normally non-current-carrying conductors, metallic enclosures, metallic raceways, metallic equipment, or earth.

Ground-Fault Current Path. An electrically conductive path from the point of a ground fault on a wiring system through normally non-current-carrying conductors, equipment, or the earth to the electrical supply source.

FPN: Examples of ground-fault current paths could consist of any combination of equipment grounding conductors, metallic raceways, metallic cable sheaths, electrical equipment, and any other electrically conductive material such as metal water and gas piping, steel framing members, stucco mesh, metal ducting, reinforcing steel, shields of communications cables, and the earth itself.

250.3 Application of Other Articles. In other articles applying to particular cases of installation of conductors and equipment, requirements are identified in Table 250.3 that are in addition to, or modifications of, those of this article.

250.4 General Requirements for Grounding and Bonding. The following general requirements identify what grounding and bonding of electrical systems are required to accomplish. The prescriptive methods contained in Article 250 shall be followed to comply with the performance requirements of this section.

(A) Grounded Systems.

(1) Electrical System Grounding. Electrical systems that are grounded shall be connected to earth in a manner that will limit the voltage imposed by lightning, line surges, or unintentional contact with higher-voltage lines and that will stabilize the voltage to earth during normal operation.

(2) Grounding of Electrical Equipment. Non-current-carrying conductive materials enclosing electrical conductors or equipment, or forming part of such equipment, shall be connected to earth so as to limit the voltage to ground on these materials.

(3) Bonding of Electrical Equipment. Non-current-carrying conductive materials enclosing electrical conductors or equipment, or forming part of such equipment, shall be connected together and to the electrical supply source in a manner that establishes an effective ground-fault current path.

(4) Bonding of Electrically Conductive Materials and Other Equipment. Electrically conductive materials that are likely to become energized shall be connected together and to the electrical supply source in a manner that establishes an effective ground-fault current path.

(5) Effective Ground-Fault Current Path. Electrical equipment and wiring and other electrically conductive material likely to become energized shall be installed in a manner that creates a permanent, low-impedance circuit facilitating the operation of the overcurrent device or ground detector for high-impedance grounded systems. It shall be capable of safely carrying the maximum ground-fault current likely to be imposed on it from any point on the wiring system where a ground fault may occur to the electrical supply source. The earth shall not be considered as an effective ground-fault current path.

Table 250.3 Additional Grounding Requirements

Conductor/Equipment	Article	Section
Branch circuits		210.5, 210.6, 406.3
Communications circuits	800	
Community antenna television and radio distribution systems		820.93, 820.100, 820.103
Conductors for general wiring	310	
Fire alarm systems		760.9
Grounding-type receptacles, adapters, cord connectors, and attachment plugs		406.9
Luminaires (lighting fixtures) and lighting equipment		410.17, 410.18, 410.20, 410.21, 410.105(B)
Luminaires (fixtures), lampholders, and lamps	410	
Outlet, device, pull, and junction boxes; conduit bodies; and fittings		314.4, 314.25
Panelboards		408.40
Receptacles and cord connectors		406.3
Services	230	
Solar photovoltaic systems		690.41, 690.42, 690.43, 690.45, 690.47 in the <i>NEC</i>
Swimming pools, fountains, and similar installations	680	
Switches		404.12

FPN No. 2: See Figure 250.4 for information on the organization of Article 250.

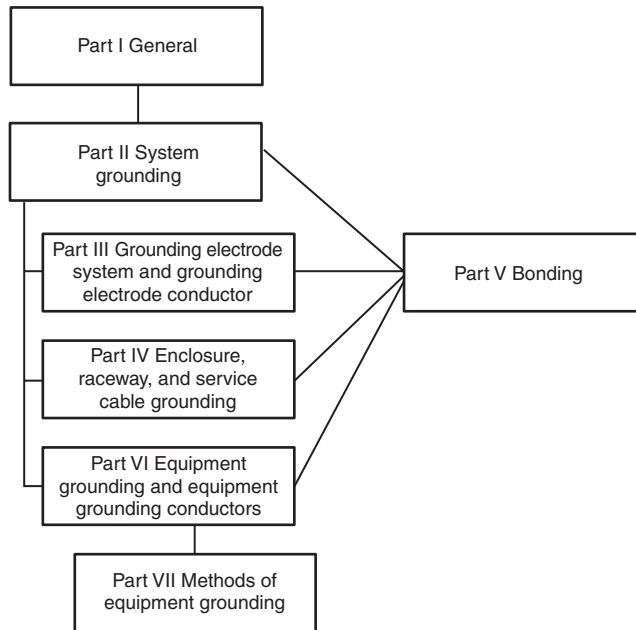

Figure 250.4 Grounding.

250.6 Objectionable Current over Grounding Conductors.

(A) Arrangement to Prevent Objectionable Current.

The grounding of electrical systems, circuit conductors, surge arresters, and conductive non-current-carrying materials and equipment shall be installed and arranged in a manner that will prevent objectionable current over the grounding conductors or grounding paths.

(B) Alterations to Stop Objectionable Current. If the use of multiple grounding connections results in objectionable current, one or more of the following alterations shall be permitted to be made, provided that the requirements of 250.4(A)(5) or (B)(4) are met:

- (1) Discontinue one or more but not all of such grounding connections.
- (2) Change the locations of the grounding connections.
- (3) Interrupt the continuity of the conductor or conductive path interconnecting the grounding connections.
- (4) Take other suitable remedial and approved action.

(C) Temporary Currents Not Classified as Objectionable Currents. Temporary currents resulting from accidental conditions, such as ground-fault currents, that occur only while the grounding conductors are performing their intended protective functions shall not be classified as objectionable current for the purposes specified in 250.6(A) and (B).

250.8 Connection of Grounding and Bonding Equipment. Grounding conductors and bonding jumpers shall be connected by exothermic welding, listed pressure connectors, listed clamps, or other listed means. Connection devices or fittings that depend solely on solder shall not be used. Sheet metal screws shall not be used to connect grounding conductors or connection devices to enclosures.

250.10 Protection of Ground Clamps and Fittings. Ground clamps or other fittings shall be approved for general use without protection or shall be protected from physical damage as indicated in (1) or (2) as follows:

- (1) In installations where they are not likely to be damaged
- (2) Where enclosed in metal, wood, or equivalent protective covering

250.12 Clean Surfaces. Nonconductive coatings (such as paint, lacquer, and enamel) on equipment to be grounded shall be removed from threads and other contact surfaces to ensure good electrical continuity or be connected by means of fittings designed so as to make such removal unnecessary.

II. System Grounding

250.20 Alternating-Current Systems to Be Grounded.

Alternating-current systems shall be grounded as provided for in 250.20(A) and (B). Other systems shall be permitted to be grounded. If such systems are grounded, they shall comply with the applicable provisions of this article.

(A) Alternating-Current Systems of Less Than 50 Volts.

Alternating-current systems of less than 50 volts shall be grounded under any of the following conditions:

- (1) Where supplied by transformers, if the transformer supply system exceeds 150 volts to ground
- (2) Where supplied by transformers, if the transformer supply system is ungrounded
- (3) Where installed as overhead conductors outside of buildings

(B) Alternating-Current Systems of 50 Volts to 1000 Volts. Alternating-current systems of 50 volts to 1000 volts that supply premises wiring and premises wiring systems shall be grounded under any of the following conditions:

- (1) Where the system can be grounded so that the maximum voltage to ground on the ungrounded conductors does not exceed 150 volts
- (2) Where the system is 3-phase, 4-wire, wye connected in which the neutral is used as a circuit conductor
- (3) Where the system is 3-phase, 4-wire, delta connected in which the midpoint of one phase winding is used as a circuit conductor

250.24 Grounding Service-Supplied Alternating-Current Systems.

(A) System Grounding Connections. A premises wiring system supplied by a grounded ac service shall have a grounding electrode conductor connected to the grounded service conductor, at each service, in accordance with 250.24(A)(1), (A)(2), and (A)(5).

(1) General. The connection shall be made at any accessible point from the load end of the service drop or service lateral to and including the terminal or bus to which the grounded service conductor is connected at the service disconnecting means.

FPN: See definitions of *Service Drop* and *Service Lateral* in Article 100.

(2) Outdoor Transformer. Where the transformer supplying the service is located outside the building, at least one additional grounding connection shall be made from the grounded service conductor to a grounding electrode, either at the transformer or elsewhere outside the building.

(5) Load-Side Grounding Connections. A grounding connection shall not be made to any grounded conductor on the load side of the service disconnecting means except as otherwise permitted in this article.

FPN: See 250.30(A) in the *NEC* for separately derived systems, 250.32 for connections at separate buildings or structures, and 250.142 for use of the grounded circuit conductor for grounding equipment.

(B) Main Bonding Jumper. For a grounded system, an unspliced main bonding jumper shall be used to connect the equipment grounding conductor(s) and the service-disconnect enclosure to the grounded conductor within the enclosure for each service disconnect in accordance with 250.28.

Exception No. 1: Where more than one service disconnecting means is located in an assembly listed for use as service equipment, an unspliced main bonding jumper shall bond the grounded conductor(s) to the assembly enclosure.

(C) Grounded Conductor Brought to Service Equipment. Where an ac system operating at less than 1000 volts is grounded at any point, the grounded conductor(s) shall be run to each service disconnecting means and shall be bonded to each disconnecting means enclosure. The grounded conductor(s) shall be installed in accordance with 250.24(C)(1) and (C)(2).

Exception: Where more than one service disconnecting means are located in an assembly listed for use as service equipment, it shall be permitted to run the grounded conductor(s) to the assembly, and the conductor(s) shall be bonded to the assembly enclosure.

(1) Routing and Sizing. This conductor shall be routed with the phase conductors and shall not be smaller than the required grounding electrode conductor specified in Table 250.66 but shall not be required to be larger than the largest ungrounded service-entrance phase conductor. In addition, for service-entrance phase conductors larger than 1100 kcmil copper or 1750 kcmil aluminum, the grounded conductor shall not be smaller than 12½ percent of the area of the largest service-entrance phase conductor. The grounded conductor of a 3-phase, 3-wire delta service shall have an ampacity not less than that of the ungrounded conductors.

(2) Parallel Conductors. Where the service-entrance phase conductors are installed in parallel, the size of the grounded conductor shall be based on the total circular mil area of the parallel conductors as indicated in this section. Where installed in two or more raceways, the size of the grounded conductor in each raceway shall be based on the size of the ungrounded service-entrance conductor in the raceway but not smaller than 1/0 AWG.

FPN: See 310.4 for grounded conductors connected in parallel.

(D) Grounding Electrode Conductor. A grounding electrode conductor shall be used to connect the equipment grounding conductors, the service-equipment enclosures, and, where the system is grounded, the grounded service conductor to the grounding electrode(s) required by Part III of this article.

FPN: See 250.24(A) for ac system grounding connections.

250.26 Conductor to Be Grounded — Alternating-Current Systems. For ac premises wiring systems, the conductor to be grounded shall be as specified in the following:

- (1) Single-phase, 2-wire — one conductor
- (2) Single-phase, 3-wire — the neutral conductor
- (3) Multiphase systems having one wire common to all phases — the common conductor
- (4) Multiphase systems where one phase is grounded — one phase conductor
- (5) Multiphase systems in which one phase is used as in (2) — the neutral conductor

250.28 Main Bonding Jumper and System Bonding Jumper. For a grounded system, main bonding jumpers and system bonding jumpers shall be installed as follows:

(A) Material. Main bonding jumpers and system bonding jumpers shall be of copper or other corrosion-resistant material. A main bonding jumper and a system bonding jumper shall be a wire, bus, screw, or similar suitable conductor.

(B) Construction. Where a main bonding jumper or a system bonding jumper is a screw only, the screw shall be

identified with a green finish that shall be visible with the screw installed.

(C) Attachment. Main bonding jumpers and system bonding jumpers shall be attached in the manner specified by the applicable provisions of 250.8.

(D) Size. Main bonding jumpers and system bonding jumpers shall not be smaller than the sizes shown in Table 250.66.

250.32 Buildings or Structures Supplied by Feeder(s) or Branch Circuit(s).

(A) Grounding Electrode. Building(s) or structure(s) supplied by feeder(s) or branch circuit(s) shall have a grounding electrode or grounding electrode system installed in accordance with 250.50. The grounding electrode conductor(s) shall be connected in accordance with 250.32(B). Where there is no existing grounding electrode, the grounding electrode(s) required in 250.50 shall be installed.

Exception: A grounding electrode shall not be required where only a single branch circuit supplies the building or structure and the branch circuit includes an equipment grounding conductor for grounding the conductive non-current-carrying parts of equipment. For the purpose of this section, a multiwire branch circuit shall be considered as a single branch circuit.

(B) Grounded Systems. For a grounded system at the separate building or structure, the connection to the grounding electrode and grounding or bonding of equipment, structures, or frames required to be grounded or bonded shall comply with either 250.32(B)(1) or (B)(2).

(1) Equipment Grounding Conductor. An equipment grounding conductor as described in 250.118 shall be run with the supply conductors and connected to the building or structure disconnecting means and to the grounding electrode(s). The equipment grounding conductor shall be used for grounding or bonding of equipment, structures, or frames required to be grounded or bonded. The equipment grounding conductor shall be sized in accordance with 250.122. Any installed grounded conductor shall not be connected to the equipment grounding conductor or to the grounding electrode(s).

(2) Grounded Conductor. Where (1) an equipment grounding conductor is not run with the supply to the building or structure, (2) there are no continuous metallic paths bonded to the grounding system in each building or structure involved, and (3) ground-fault protection of equipment has not been installed on the supply side of the feeder(s), the grounded conductor run with the supply to the building or structure shall be connected to the building or structure disconnecting means and to the grounding electrode(s) and

shall be used for grounding or bonding of equipment, structures, or frames required to be grounded or bonded. The size of the grounded conductor shall not be smaller than the larger of either of the following:

- (1) That required by 220.61
- (2) That required by 250.122

(E) Grounding Electrode Conductor. The size of the grounding electrode conductor to the grounding electrode(s) shall not be smaller than given in 250.66, based on the largest ungrounded supply conductor. The installation shall comply with Part III of this article.

III. Grounding Electrode System and Grounding Electrode Conductor

250.50 Grounding Electrode System. All grounding electrodes as described in 250.52(A)(1) through (A)(6) that are present at each building or structure served shall be bonded together to form the grounding electrode system. Where none of these grounding electrodes exist, one or more of the grounding electrodes specified in 250.52(A)(4) through (A)(7) shall be installed and used.

Exception: Concrete-encased electrodes of existing buildings or structures shall not be required to be part of the grounding electrode system where the steel reinforcing bars or rods are not accessible for use without disturbing the concrete.

250.52 Grounding Electrodes.

(A) Electrodes Permitted for Grounding.

(1) Metal Underground Water Pipe. A metal underground water pipe in direct contact with the earth for 3.0 m (10 ft) or more (including any metal well casing effectively bonded to the pipe) and electrically continuous (or made electrically continuous by bonding around insulating joints or insulating pipe) to the points of connection of the grounding electrode conductor and the bonding conductors. Interior metal water piping located more than 1.52 m (5 ft) from the point of entrance to the building shall not be used as a part of the grounding electrode system or as a conductor to interconnect electrodes that are part of the grounding electrode system.

Exception: In industrial and commercial buildings or structures where conditions of maintenance and supervision ensure that only qualified persons service the installation, interior metal water piping located more than 1.52 m (5 ft) from the point of entrance to the building shall be permitted as a part of the grounding electrode system or as a conductor to interconnect electrodes that are part of the grounding electrode system, provided that the entire length, other than

short sections passing perpendicular through walls, floors, or ceilings, of the interior metal water pipe that is being used for the conductor is exposed.

(2) Metal Frame of the Building or Structure. The metal frame of the building or structure, where any of the following methods are used to make an earth connection:

- (1) 3.0 m (10 ft) or more of a single structural metal member in direct contact with the earth or encased in concrete that is in direct contact with the earth
- (2) The structural metal frame is bonded to one or more of the grounding electrodes as defined in 250.52(A)(1), (A)(3), or (A)(4)
- (3) The structural metal frame is bonded to one or more of the grounding electrodes as defined in 250.52(A)(5) or (A)(6) that comply with 250.56, or
- (4) Other approved means of establishing a connection to earth.

(3) Concrete-Encased Electrode. An electrode encased by at least 50 mm (2 in.) of concrete, located within and near the bottom of a concrete foundation or footing that is in direct contact with the earth, consisting of at least 6.0 m (20 ft) of one or more bare or zinc galvanized or other electrically conductive coated steel reinforcing bars or rods of not less than 13 mm (½ in.) in diameter, or consisting of at least 6.0 m (20 ft) of bare copper conductor not smaller than 4 AWG. Reinforcing bars shall be permitted to be bonded together by the usual steel tie wires or other effective means.

(4) Ground Ring. A ground ring encircling the building or structure, in direct contact with the earth, consisting of at least 6.0 m (20 ft) of bare copper conductor not smaller than 2 AWG.

(5) Rod and Pipe Electrodes. Rod and pipe electrodes shall not be less than 2.5 m (8 ft) in length and shall consist of the following materials.

(a) Electrodes of pipe or conduit shall not be smaller than metric designator 21 (trade size ¾) and, where of iron or steel, shall have the outer surface galvanized or otherwise metal-coated for corrosion protection.

(b) Electrodes of rods of iron or steel shall be at least 15.87 mm (⅝ in.) in diameter. Stainless steel rods less than 16 mm (⅝ in.) in diameter, nonferrous rods, or their equivalent shall be listed and shall not be less than 13 mm (½ in.) in diameter.

(6) Plate Electrodes. Each plate electrode shall expose not less than 0.186 m² (2 ft²) of surface to exterior soil. Electrodes of iron or steel plates shall be at least 6.4 mm (¼ in.) in thickness. Electrodes of nonferrous metal shall be at least 1.5 mm (0.06 in.) in thickness.

(7) Other Local Metal Underground Systems or Structures. Other local metal underground systems or structures such as piping systems, underground tanks, and underground metal well casings that are not effectively bonded to a metal water pipe.

(B) Electrodes Not Permitted for Grounding. The following shall not be used as grounding electrodes:

- (1) Metal underground gas piping system
- (2) Aluminum electrodes

FPN: See 250.104(B) for bonding requirements of gas piping.

250.53 Grounding Electrode System Installation.

(A) Rod, Pipe, and Plate Electrodes. Where practicable, rod, pipe, and plate electrodes shall be embedded below permanent moisture level. Rod, pipe, and plate electrodes shall be free from nonconductive coatings such as paint or enamel.

(B) Electrode Spacing. Where more than one of the electrodes of the type specified in 250.52(A)(5) or (A)(6) are used, each electrode of one grounding system (including that used for air terminals) shall not be less than 1.83 m (6 ft) from any other electrode of another grounding system. Two or more grounding electrodes that are effectively bonded together shall be considered a single grounding electrode system.

(C) Bonding Jumper. The bonding jumper(s) used to connect the grounding electrodes together to form the grounding electrode system shall be installed in accordance with 250.64(A), (B), and (E), shall be sized in accordance with 250.66, and shall be connected in the manner specified in 250.70.

(D) Metal Underground Water Pipe. Where used as a grounding electrode, metal underground water pipe shall meet the requirements of 250.53(D)(1) and (D)(2).

(1) Continuity. Continuity of the grounding path or the bonding connection to interior piping shall not rely on water meters or filtering devices and similar equipment.

(2) Supplemental Electrode Required. A metal underground water pipe shall be supplemented by an additional electrode of a type specified in 250.52(A)(2) through (A)(7). Where the supplemental electrode is a rod, pipe, or plate type, it shall comply with 250.56. The supplemental electrode shall be permitted to be bonded to the grounding electrode conductor, the grounded service-entrance conductor, the nonflexible grounded service raceway, or any grounded service enclosure.

Exception: The supplemental electrode shall be permitted to be bonded to the interior metal water piping at any convenient point as covered in 250.52(A)(1), Exception.

(E) Supplemental Electrode Bonding Connection Size. Where the supplemental electrode is a rod, pipe, or plate electrode, that portion of the bonding jumper that is the sole connection to the supplemental grounding electrode shall not be required to be larger than 6 AWG copper wire or 4 AWG aluminum wire.

(F) Ground Ring. The ground ring shall be buried at a depth below the earth's surface of not less than 750 mm (30 in.).

(G) Rod and Pipe Electrodes. The electrode shall be installed such that at least 2.44 m (8 ft) of length is in contact with the soil. It shall be driven to a depth of not less than 2.44 m (8 ft) except that, where rock bottom is encountered, the electrode shall be driven at an oblique angle not to exceed 45 degrees from the vertical or, where rock bottom is encountered at an angle up to 45 degrees, the electrode shall be permitted to be buried in a trench that is at least 750 mm (30 in.) deep. The upper end of the electrode shall be flush with or below ground level unless the aboveground end and the grounding electrode conductor attachment are protected against physical damage as specified in 250.10.

(H) Plate Electrode. Plate electrodes shall be installed not less than 750 mm (30 in.) below the surface of the earth.

250.54 Supplementary Grounding Electrodes. Supplementary grounding electrodes shall be permitted to be connected to the equipment grounding conductors specified in 250.118 and shall not be required to comply with the electrode bonding requirements of 250.50 or 250.53(C) or the resistance requirements of 250.56, but the earth shall not be used as an effective ground-fault current path as specified in 250.4(A)(5).

250.56 Resistance of Rod, Pipe, and Plate Electrodes. A single electrode consisting of a rod, pipe, or plate that does not have a resistance to ground of 25 ohms or less shall be augmented by one additional electrode of any of the types specified by 250.52(A)(2) through (A)(7). Where multiple rod, pipe, or plate electrodes are installed to meet the requirements of this section, they shall not be less than 1.8 m (6 ft) apart.

FPN: The paralleling efficiency of rods longer than 2.5 m (8 ft) is improved by spacing greater than 1.8 m (6 ft).

250.58 Common Grounding Electrode. Where an ac system is connected to a grounding electrode in or at a building or structure, the same electrode shall be used to ground conductor enclosures and equipment in or on that building

or structure. Where separate services, feeders, or branch circuits supply a building and are required to be connected to a grounding electrode(s), the same grounding electrode(s) shall be used.

Two or more grounding electrodes that are effectively bonded together shall be considered as a single grounding electrode system in this sense.

250.60 Use of Air Terminals. Air terminal conductors and driven pipes, rods, or plate electrodes used for grounding air terminals shall not be used in lieu of the grounding electrodes required by 250.50 for grounding wiring systems and equipment. This provision shall not prohibit the required bonding together of grounding electrodes of different systems.

FPN No. 1: See 250.106 for spacing from air terminals. See 800.100(D), 810.21(J) in the *NEC*, and 820.100(D) for bonding of electrodes.

FPN No. 2: Bonding together of all separate grounding electrodes will limit potential differences between them and between their associated wiring systems.

250.62 Grounding Electrode Conductor Material. The grounding electrode conductor shall be of copper, aluminum, or copper-clad aluminum. The material selected shall be resistant to any corrosive condition existing at the installation or shall be suitably protected against corrosion. The conductor shall be solid or stranded, insulated, covered, or bare.

250.64 Grounding Electrode Conductor Installation. Grounding electrode conductors shall be installed as specified in 250.64(A) through (F).

(A) Aluminum or Copper-Clad Aluminum Conductors. Bare aluminum or copper-clad aluminum grounding conductors shall not be used where in direct contact with masonry or the earth or where subject to corrosive conditions. Where used outside, aluminum or copper-clad aluminum grounding conductors shall not be terminated within 450 mm (18 in.) of the earth.

(B) Securing and Protection Against Physical Damage. Where exposed, a grounding electrode conductor or its enclosure shall be securely fastened to the surface on which it is carried. A 4 AWG or larger copper or aluminum grounding electrode conductor shall be protected where exposed to physical damage. A 6 AWG grounding electrode conductor that is free from exposure to physical damage shall be permitted to be run along the surface of the building construction without metal covering or protection where it is securely fastened to the construction; otherwise, it shall be in rigid metal conduit, intermediate metal conduit, rigid nonmetallic conduit, electrical metallic tubing, or cable armor. Grounding electrode conductors smaller than 6 AWG shall be in rigid

metal conduit, intermediate metal conduit, rigid nonmetallic conduit, electrical metallic tubing, or cable armor.

(C) Continuous. Grounding electrode conductor(s) shall be installed in one continuous length without a splice or joint except as permitted in (1) through (4):

- (1) Splicing shall be permitted only by irreversible compression-type connectors listed as grounding and bonding equipment or by the exothermic welding process.
- (2) Sections of busbars shall be permitted to be connected together to form a grounding electrode conductor.
- (3) Bonding jumper(s) from grounding electrode(s) and grounding electrode conductor(s) shall be permitted to be connected to an aluminum or copper busbar not less than 6 mm × 50 mm (¼ in. × 2 in.). The busbar shall be securely fastened and shall be installed in an accessible location. Connections shall be made by a listed connector or by the exothermic welding process.
- (4) Where aluminum busbars are used, the installation shall comply with 250.64(A).

(D) Grounding Electrode Conductor Taps. Where a service consists of more than a single enclosure as permitted in 230.71(A), it shall be permitted to connect taps to the common grounding electrode conductor. Each such tap conductor shall extend to the inside of each such enclosure. The common grounding electrode conductor shall be sized in accordance with 250.66, based on the sum of the circular mil area of the largest ungrounded service entrance conductors. Where more than one set of service entrance conductors as permitted by 230.40, Exception No. 2 connect directly to a service drop or lateral, the common grounding electrode conductor shall be sized in accordance with Table 250.66 Note 1. The tap conductors shall be permitted to be sized in accordance with the grounding electrode conductors specified in 250.66 for the largest conductor serving the respective enclosures. The tap conductors shall be connected to the common grounding electrode conductor in such a manner that the common grounding electrode conductor remains without a splice or joint.

(E) Enclosures for Grounding Electrode Conductors. Ferrous metal enclosures for grounding electrode conductors shall be electrically continuous from the point of attachment to cabinets or equipment to the grounding electrode and shall be securely fastened to the ground clamp or fitting. Nonferrous metal enclosures shall not be required to be electrically continuous. Ferrous metal enclosures that are not physically continuous from cabinets or equipment to the grounding electrode shall be made electrically continuous by bonding each end of the raceway or enclosure to the grounding electrode conductor. Bonding shall apply at each end and to all intervening ferrous raceways, boxes, and enclosures between the service equipment and the grounding

electrode. The bonding jumper for a grounding electrode conductor raceway or cable armor shall be the same size as, or larger than, the required enclosed grounding electrode conductor. Where a raceway is used as protection for a grounding electrode conductor, the installation shall comply with the requirements of the appropriate raceway article.

(F) To Electrode(s). A grounding electrode conductor shall be permitted to be run to any convenient grounding electrode available in the grounding electrode system, or to one or more grounding electrode(s) individually, or to the aluminum or copper busbar as permitted in 250.64(C). The grounding electrode conductor shall be sized for the largest grounding electrode conductor required among all the electrodes connected to it.

250.66 Size of Alternating-Current Grounding Electrode Conductor. The size of the grounding electrode conductor of a grounded or ungrounded ac system shall not be less than given in Table 250.66, except as permitted in 250.66(A) through (C).

Table 250.66 Grounding Electrode Conductor for Alternating-Current Systems

Size of Largest Ungrounded Service-Entrance Conductor or Equivalent Area for Parallel Conductors ^a (AWG/kcmil)		Size of Grounding Electrode Conductor (AWG/kcmil)	
Copper	Aluminum or Copper-Clad Aluminum	Copper	Aluminum or Copper-Clad Aluminum ^b
2 or smaller	1/0 or smaller	8	6
1 or 1/0	2/0 or 3/0	6	4
2/0 or 3/0	4/0 or 250	4	2
Over 3/0 through 350	Over 250 through 500	2	1/0
Over 350 through 600	Over 500 through 900	1/0	3/0

Notes:

1. Where multiple sets of service-entrance conductors are used as permitted in 230.40, Exception No. 2, the equivalent size of the largest service-entrance conductor shall be determined by the largest sum of the areas of the corresponding conductors of each set.

2. Where there are no service-entrance conductors, the grounding electrode conductor size shall be determined by the equivalent size of the largest service-entrance conductor required for the load to be served.

^aThis table also applies to the derived conductors of separately derived ac systems.

^bSee installation restrictions in 250.64(A).

FPN: See 250.24(C) for size of ac system conductor brought to service equipment.

(A) Connections to Rod, Pipe, or Plate Electrodes.

Where the grounding electrode conductor is connected to rod, pipe, or plate electrodes as permitted in 250.52(A)(5) or (A)(6), that portion of the conductor that is the sole connection to the grounding electrode shall not be required to be larger than 6 AWG copper wire or 4 AWG aluminum wire.

(B) Connections to Concrete-Encased Electrodes.

Where the grounding electrode conductor is connected to a concrete-encased electrode as permitted in 250.52(A)(3), that portion of the conductor that is the sole connection to the grounding electrode shall not be required to be larger than 4 AWG copper wire.

(C) Connections to Ground Rings. Where the grounding electrode conductor is connected to a ground ring as permitted in 250.52(A)(4), that portion of the conductor that is the sole connection to the grounding electrode shall not be required to be larger than the conductor used for the ground ring.

250.68 Grounding Electrode Conductor and Bonding Jumper Connection to Grounding Electrodes.

(A) Accessibility. The connection of a grounding electrode conductor or bonding jumper to a grounding electrode shall be accessible.

Exception No. 1: An encased or buried connection to a concrete-encased, driven, or buried grounding electrode shall not be required to be accessible.

Exception No. 2: An exothermic or irreversible compression connection to fire-proofed structural metal shall not be required to be accessible.

(B) Effective Grounding Path. The connection of a grounding electrode conductor or bonding jumper to a grounding electrode shall be made in a manner that will ensure a permanent and effective grounding path. Where necessary to ensure the grounding path for a metal piping system used as a grounding electrode, effective bonding shall be provided around insulated joints and around any equipment likely to be disconnected for repairs or replacement. Bonding conductors shall be of sufficient length to permit removal of such equipment while retaining the integrity of the bond.

250.70 Methods of Grounding and Bonding Conductor Connection to Electrodes.

The grounding or bonding conductor shall be connected to the grounding electrode by exothermic welding, listed lugs, listed pressure connectors, listed clamps, or other listed means. Connections depending

on solder shall not be used. Ground clamps shall be listed for the materials of the grounding electrode and the grounding electrode conductor and, where used on pipe, rod, or other buried electrodes, shall also be listed for direct soil burial or concrete encasement. Not more than one conductor shall be connected to the grounding electrode by a single clamp or fitting unless the clamp or fitting is listed for multiple conductors. One of the following methods shall be used:

- (1) A pipe fitting, pipe plug, or other approved device screwed into a pipe or pipe fitting
- (2) A listed bolted clamp of cast bronze or brass, or plain or malleable iron
- (3) For indoor telecommunications purposes only, a listed sheet metal strap-type ground clamp having a rigid metal base that seats on the electrode and having a strap of such material and dimensions that it is not likely to stretch during or after installation
- (4) An equally substantial approved means

IV. Enclosure, Raceway, and Service Cable Grounding

250.80 Service Raceways and Enclosures. Metal enclosures and raceways for service conductors and equipment shall be grounded.

Exception: A metal elbow that is installed in an underground installation of rigid nonmetallic conduit and is isolated from possible contact by a minimum cover of 450 mm (18 in.) to any part of the elbow shall not be required to be grounded.

250.84 Underground Service Cable or Raceway.

(A) Underground Service Cable. The sheath or armor of a continuous underground metal-sheathed or armored service cable system that is bonded to the grounded underground system shall not be required to be grounded at the building or structure. The sheath or armor shall be permitted to be insulated from the interior metal raceway conduit or piping.

(B) Underground Service Raceway Containing Cable.

An underground metal service raceway that contains a metal-sheathed or armored cable bonded to the grounded underground system shall not be required to be grounded at the building or structure. The sheath or armor shall be permitted to be insulated from the interior metal raceway or piping.

250.86 Other Conductor Enclosures and Raceways. Except as permitted by 250.112(I), metal enclosures and raceways for other than service conductors shall be grounded.

Exception No. 1: Metal enclosures and raceways for conductors added to existing installations of open wire, knob and tube wiring, and nonmetallic-sheathed cable shall not be required to be grounded where these enclosures or wiring methods comply with (1) through (4) as follows:

- (1) Do not provide an equipment ground
- (2) Are in runs of less than 7.5 m (25 ft)
- (3) Are free from probable contact with ground, grounded metal, metal lath, or other conductive material
- (4) Are guarded against contact by persons

Exception No. 2: Short sections of metal enclosures or raceways used to provide support or protection of cable assemblies from physical damage shall not be required to be grounded.

Exception No. 3: A metal elbow shall not be required to be grounded where it is installed in a nonmetallic raceway and is isolated from possible contact by a minimum cover of 450 mm (18 in.) to any part of the elbow or is encased in not less than 50 mm (2 in.) of concrete.

V. Bonding

250.90 General. Bonding shall be provided where necessary to ensure electrical continuity and the capacity to conduct safely any fault current likely to be imposed.

250.92 Services.

(A) Bonding of Services. The non-current-carrying metal parts of equipment indicated in 250.92(A)(1), (A)(2), and (A)(3) shall be effectively bonded together.

- (1) The service raceways, cable trays, cablebus framework, auxiliary gutters, or service cable armor or sheath except as permitted in 250.84.
- (2) All service enclosures containing service conductors, including meter fittings, boxes, or the like, interposed in the service raceway or armor.
- (3) Any metallic raceway or armor enclosing a grounding electrode conductor as specified in 250.64(B). Bonding shall apply at each end and to all intervening raceways, boxes, and enclosures between the service equipment and the grounding electrode.

(B) Method of Bonding at the Service. Electrical continuity at service equipment, service raceways, and service conductor enclosures shall be ensured by one of the following methods:

- (1) Bonding equipment to the grounded service conductor in a manner provided in 250.8
- (2) Connections utilizing threaded couplings or threaded bosses on enclosures where made up wrenchtight
- (3) Threadless couplings and connectors where made up tight for metal raceways and metal-clad cables
- (4) Other listed devices, such as bonding-type locknuts, bushings, or bushings with bonding jumpers

Bonding jumpers meeting the other requirements of this article shall be used around concentric or eccentric knock-

outs that are punched or otherwise formed so as to impair the electrical connection to ground. Standard locknuts or bushings shall not be the sole means for the bonding required by this section.

250.94 Bonding for Other Systems. An accessible means external to enclosures for connecting intersystem bonding and grounding electrode conductors shall be provided at the service equipment and at the disconnecting means for any additional buildings or structures by at least one of the following means:

- (1) Exposed nonflexible metallic raceways
- (2) Exposed grounding electrode conductor
- (3) Approved means for the external connection of a copper or other corrosion-resistant bonding or grounding conductor to the grounded raceway or equipment

FPN No. 1: A 6 AWG copper conductor with one end bonded to the grounded nonflexible metallic raceway or equipment and with 150 mm (6 in.) or more of the other end made accessible on the outside wall is an example of the approved means covered in 250.94(3).

FPN No. 2: See 800.100, 810.21, and 820.100 for bonding and grounding requirements for communications circuits, radio and television equipment, and CATV circuits.

250.96 Bonding Other Enclosures.

(A) General. Metal raceways, cable trays, cable armor, cable sheath, enclosures, frames, fittings, and other metal non-current-carrying parts that are to serve as grounding conductors, with or without the use of supplementary equipment grounding conductors, shall be effectively bonded where necessary to ensure electrical continuity and the capacity to conduct safely any fault current likely to be imposed on them. Any nonconductive paint, enamel, or similar coating shall be removed at threads, contact points, and contact surfaces or be connected by means of fittings designed so as to make such removal unnecessary.

250.102 Equipment Bonding Jumpers.

(A) Material. Equipment bonding jumpers shall be of copper or other corrosion-resistant material. A bonding jumper shall be a wire, bus, screw, or similar suitable conductor.

(B) Attachment. Equipment bonding jumpers shall be attached in the manner specified by the applicable provisions of 250.8 for circuits and equipment and by 250.70 for grounding electrodes.

(C) Size — Equipment Bonding Jumper on Supply Side of Service. The bonding jumper shall not be smaller than the sizes shown in Table 250.66 for grounding electrode conductors. Where the service-entrance phase conductors are larger than 1100 kcmil copper or 1750 kcmil aluminum,

the bonding jumper shall have an area not less than 12½ percent of the area of the largest phase conductor except that, where the phase conductors and the bonding jumper are of different materials (copper or aluminum), the minimum size of the bonding jumper shall be based on the assumed use of phase conductors of the same material as the bonding jumper and with an ampacity equivalent to that of the installed phase conductors. Where the service-entrance conductors are paralleled in two or more raceways or cables, the equipment bonding jumper, where routed with the raceways or cables, shall be run in parallel. The size of the bonding jumper for each raceway or cable shall be based on the size of the service-entrance conductors in each raceway or cable.

(D) Size — Equipment Bonding Jumper on Load Side of Service. The equipment bonding jumper on the load side of the service overcurrent devices shall be sized, as a minimum, in accordance with the sizes listed in Table 250.122, but shall not be required to be larger than the largest ungrounded circuit conductors supplying the equipment and shall not be smaller than 14 AWG.

A single common continuous equipment bonding jumper shall be permitted to bond two or more raceways or cables where the bonding jumper is sized in accordance with Table 250.122 for the largest overcurrent device supplying circuits therein.

(E) Installation. The equipment bonding jumper shall be permitted to be installed inside or outside of a raceway or enclosure. Where installed on the outside, the length of the equipment bonding jumper shall not exceed 1.8 m (6 ft) and shall be routed with the raceway or enclosure. Where installed inside of a raceway, the equipment bonding jumper shall comply with the requirements of 250.119 and 250.148.

Exception: An equipment bonding jumper longer than 1.8 m (6 ft) shall be permitted at outside pole locations for the purpose of bonding or grounding isolated sections of metal raceways or elbows installed in exposed risers of metal conduit or other metal raceway.

250.104 Bonding of Piping Systems and Exposed Structural Steel.

(A) Metal Water Piping. The metal water piping system shall be bonded as required in (A)(1), (A)(2), or (A)(3) of this section. The bonding jumper(s) shall be installed in accordance with 250.64(A), (B), and (E). The points of attachment of the bonding jumper(s) shall be accessible.

(1) General. Metal water piping system(s) installed in or attached to a building or structure shall be bonded to the service equipment enclosure, the grounded conductor at the service, the grounding electrode conductor where of sufficient size, or to the one or more grounding electrodes used.

The bonding jumper(s) shall be sized in accordance with Table 250.66 except as permitted in 250.104(A)(2) and (A)(3).

(2) Buildings of Multiple Occupancy. In buildings of multiple occupancy where the metal water piping system(s) installed in or attached to a building or structure for the individual occupancies is metallically isolated from all other occupancies by use of nonmetallic water piping, the metal water piping system(s) for each occupancy shall be permitted to be bonded to the equipment grounding terminal of the panelboard or switchboard enclosure (other than service equipment) supplying that occupancy. The bonding jumper shall be sized in accordance with Table 250.122.

(3) Multiple Buildings or Structures Supplied by a Feeder(s) or Branch Circuit(s). The metal water piping system(s) installed in or attached to a building or structure shall be bonded to the building or structure disconnecting means enclosure where located at the building or structure, to the equipment grounding conductor run with the supply conductors, or to the one or more grounding electrodes used. The bonding jumper(s) shall be sized in accordance with 250.66, based on the size of the feeder or branch circuit conductors that supply the building. The bonding jumper shall not be required to be larger than the largest ungrounded feeder or branch circuit conductor supplying the building.

(B) Other Metal Piping. Where installed in or attached to a building or structure, metal piping system(s), including gas piping, that is likely to become energized shall be bonded to the service equipment enclosure, the grounded conductor at the service, the grounding electrode conductor where of sufficient size, or to the one or more grounding electrodes used. The bonding jumper(s) shall be sized in accordance with 250.122, using the rating of the circuit that is likely to energize the piping system(s). The equipment grounding conductor for the circuit that is likely to energize the piping shall be permitted to serve as the bonding means. The points of attachment of the bonding jumper(s) shall be accessible.

FPN: Bonding all piping and metal air ducts within the premises will provide additional safety.

250.106 Lightning Protection Systems. The lightning protection system ground terminals shall be bonded to the building or structure grounding electrode system.

FPN No. 1: See 250.60 for use of air terminals. For further information, see NFPA 780-2004, *Standard for the Installation of Lightning Protection Systems*, which contains detailed information on grounding, bonding, and spacing from lightning protection systems.

FPN No. 2: Metal raceways, enclosures, frames, and other non-current-carrying metal parts of electric equipment installed on a building equipped with a lightning protection system may require bonding or spacing from the lightning

protection conductors in accordance with NFPA 780-2004, *Standard for the Installation of Lightning Protection Systems*. Separation from lightning protection conductors is typically 1.8 m (6 ft) through air or 900 mm (3 ft) through dense materials such as concrete, brick, or wood.

VI. Equipment Grounding and Equipment Grounding Conductors

250.110 Equipment Fastened in Place or Connected by Permanent Wiring Methods (Fixed). Exposed non-current-carrying metal parts of fixed equipment likely to become energized shall be grounded under any of the following conditions:

- (1) Where within 2.5 m (8 ft) vertically or 1.5 m (5 ft) horizontally of ground or grounded metal objects and subject to contact by persons
- (2) Where located in a wet or damp location and not isolated
- (3) Where in electrical contact with metal
- (5) Where supplied by a metal-clad, metal-sheathed, metal-raceway, or other wiring method that provides an equipment ground, except as permitted by 250.86, Exception No. 2, for short sections of metal enclosures
- (6) Where equipment operates with any terminal at over 150 volts to ground

Exception No. 1: Metal frames of electrically heated appliances, exempted by special permission, in which case the frames shall be permanently and effectively insulated from ground.

250.112 Fastened in Place or Connected by Permanent Wiring Methods (Fixed) — Specific. Exposed, non-current-carrying metal parts of the kinds of equipment described in 250.112(I) and (J), and non-current-carrying metal parts of equipment and enclosures described in 250.112(L) and (M), shall be grounded regardless of voltage.

(I) Power-Limited Remote-Control, Signaling, and Fire Alarm Circuits. Equipment supplied by Class 1 power-limited circuits and Class 1, Class 2, and Class 3 remote-control and signaling circuits, and by fire alarm circuits, shall be grounded where system grounding is required by Part II or Part VIII of this article.

(J) Luminaires (Lighting Fixtures). Luminaires (lighting fixtures) as provided in Part V of Article 410.

(L) Motor-Operated Water Pumps. Motor-operated water pumps, including the submersible type.

(M) Metal Well Casings. Where a submersible pump is used in a metal well casing, the well casing shall be bonded to the pump circuit equipment grounding conductor.

250.114 Equipment Connected by Cord and Plug. Under any of the conditions described in 250.114(3), exposed non-current-carrying metal parts of cord-and-plug-connected equipment likely to become energized shall be grounded.

Exception: Listed tools, listed appliances, and listed equipment covered in 250.114(3) shall not be required to be grounded where protected by a system of double insulation or its equivalent. Double insulated equipment shall be distinctively marked.

- (3) In residential occupancies:
 - a. Refrigerators, freezers, and air conditioners
 - b. Clothes-washing, clothes-drying, dish-washing machines; kitchen waste disposers; information technology equipment; sump pumps and electrical aquarium equipment
 - c. Hand-held motor-operated tools, stationary and fixed motor-operated tools, light industrial motor-operated tools
 - d. Motor-operated appliances of the following types: hedge clippers, lawn mowers, snow blowers, and wet scrubbers
 - e. Portable handlamps

250.116 Nonelectric Equipment.

FPN: Where extensive metal in or on buildings may become energized and is subject to personal contact, adequate bonding and grounding will provide additional safety.

250.118 Types of Equipment Grounding Conductors.

The equipment grounding conductor run with or enclosing the circuit conductors shall be one or more or a combination of the following:

- (1) A copper, aluminum, or copper-clad aluminum conductor. This conductor shall be solid or stranded; insulated, covered, or bare; and in the form of a wire or a busbar of any shape.
- (2) Rigid metal conduit.
- (3) Intermediate metal conduit.
- (4) Electrical metallic tubing.
- (5) Listed flexible metal conduit meeting all the following conditions:
 - a. The conduit is terminated in fittings listed for grounding.
 - b. The circuit conductors contained in the conduit are protected by overcurrent devices rated at 20 amperes or less.
 - c. The combined length of flexible metal conduit and flexible metallic tubing and liquidtight flexible metal conduit in the same ground return path does not exceed 1.8 m (6 ft).

- d. Where used to connect equipment where flexibility is necessary after installation, an equipment grounding conductor shall be installed.
- (6) Listed liquidtight flexible metal conduit meeting all the following conditions:
 - a. The conduit is terminated in fittings listed for grounding.
 - b. For metric designators 12 through 16 (trade sizes $\frac{3}{8}$ through $\frac{1}{2}$), the circuit conductors contained in the conduit are protected by overcurrent devices rated at 20 amperes or less.
 - c. For metric designators 21 through 35 (trade sizes $\frac{3}{4}$ through $1\frac{1}{4}$), the circuit conductors contained in the conduit are protected by overcurrent devices rated not more than 60 amperes and there is no flexible metal conduit, flexible metallic tubing, or liquidtight flexible metal conduit in trade sizes metric designators 12 through 16 (trade sizes $\frac{3}{8}$ through $\frac{1}{2}$) in the grounding path.
 - d. The combined length of flexible metal conduit and flexible metallic tubing and liquidtight flexible metal conduit in the same ground return path does not exceed 1.8 m (6 ft).
 - e. Where used to connect equipment where flexibility is necessary after installation, an equipment grounding conductor shall be installed.
- (7) Flexible metallic tubing where the tubing is terminated in fittings listed for grounding and meeting the following conditions:
 - a. The circuit conductors contained in the tubing are protected by overcurrent devices rated at 20 amperes or less.
 - b. The combined length of flexible metal conduit and flexible metallic tubing and liquidtight flexible metal conduit in the same ground return path does not exceed 1.8 m (6 ft).
- (8) Armor of Type AC cable as provided in 320.108 in the *NEC*.
- (10) Type MC cable where listed and identified for grounding in accordance with the following:
 - a. The combined metallic sheath and grounding conductor of interlocked metal tape-type MC cable
 - b. The metallic sheath or the combined metallic sheath and grounding conductors of the smooth or corrugated tube type MC cable
- (13) Other listed electrically continuous metal raceways and listed auxiliary gutters.
- (14) Surface metal raceways listed for grounding.

250.119 Identification of Equipment Grounding Conductors. Unless required elsewhere in this *Code*, equipment

grounding conductors shall be permitted to be bare, covered, or insulated. Individually covered or insulated equipment grounding conductors shall have a continuous outer finish that is either green or green with one or more yellow stripes except as permitted in this section. Conductors with insulation or individual covering that is green, green with one or more yellow stripes, or otherwise identified as permitted by this section shall not be used for ungrounded or grounded circuit conductors.

(A) Conductors Larger Than 6 AWG. Equipment grounding conductors larger than 6 AWG shall comply with 250.119(A)(1) and (A)(2).

- (1) An insulated or covered conductor larger than 6 AWG shall be permitted, at the time of installation, to be permanently identified as an equipment grounding conductor at each end and at every point where the conductor is accessible.

Exception: Conductors larger than 6 AWG shall not be required to be marked in conduit bodies that contain no splices or unused hubs.

- (2) Identification shall encircle the conductor and shall be accomplished by one of the following:
 - a. Stripping the insulation or covering from the entire exposed length
 - b. Coloring the exposed insulation or covering green
 - c. Marking the exposed insulation or covering with green tape or green adhesive labels

250.120 Equipment Grounding Conductor Installation. An equipment grounding conductor shall be installed in accordance with 250.120(A), (B), and (C).

(A) Raceway, Cable Trays, Cable Armor, Cablebus, or Cable Sheaths. Where it consists of a raceway, cable tray, cable armor, cablebus framework, or cable sheath or where it is a wire within a raceway or cable, it shall be installed in accordance with the applicable provisions in this *Code* using fittings for joints and terminations approved for use with the type raceway or cable used. All connections, joints, and fittings shall be made tight using suitable tools.

(B) Aluminum and Copper-Clad Aluminum Conductors. Equipment grounding conductors of bare or insulated aluminum or copper-clad aluminum shall be permitted. Bare conductors shall not come in direct contact with masonry or the earth or where subject to corrosive conditions. Aluminum or copper-clad aluminum conductors shall not be terminated within 450 mm (18 in.) of the earth.

(C) Equipment Grounding Conductors Smaller Than 6 AWG. Equipment grounding conductors smaller than 6

AWG shall be protected from physical damage by a raceway or cable armor except where run in hollow spaces of walls or partitions, where not subject to physical damage, or where protected from physical damage.

250.122 Size of Equipment Grounding Conductors.

(A) General. Copper, aluminum, or copper-clad aluminum equipment grounding conductors of the wire type shall not be smaller than shown in Table 250.122 but shall not be required to be larger than the circuit conductors supplying the equipment. Where a raceway or a cable armor or sheath is used as the equipment grounding conductor, as provided in 250.118 and 250.134(A), it shall comply with 250.4(A)(5).

(B) Increased in Size. Where ungrounded conductors are increased in size, equipment grounding conductors, where installed, shall be increased in size proportionately according to circular mil area of the ungrounded conductors.

(C) Multiple Circuits. Where a single equipment grounding conductor is run with multiple circuits in the same raceway or cable, it shall be sized for the largest overcurrent device protecting conductors in the raceway or cable.

(E) Flexible Cord and Fixture Wire. The equipment grounding conductor in a flexible cord with the largest circuit conductor 10 AWG or smaller, and the equipment grounding conductor used with fixture wires of any size in accordance with 240.5 in the *NEC*, shall not be smaller than 18 AWG copper and shall not be smaller than the circuit conductors. The equipment grounding conductor in a flexible cord with a circuit conductor larger than 10 AWG shall be sized in accordance with Table 250.122.

(F) Conductors in Parallel. Where conductors are run in parallel in multiple raceways or cables as permitted in 310.4, the equipment grounding conductors, where used, shall be run in parallel in each raceway or cable. One of the methods in 250.122(F)(1) shall be used to ensure the equipment grounding conductors are protected.

(1) Based on Rating of Overcurrent Protective Device. Each parallel equipment grounding conductor shall be sized on the basis of the ampere rating of the overcurrent device protecting the circuit conductors in the raceway or cable in accordance with Table 250.122.

250.124 Equipment Grounding Conductor Continuity.

(A) Separable Connections. Separable connections such as those provided in drawout equipment or attachment plugs and mating connectors and receptacles shall provide for first-make, last-break of the equipment grounding conductor. First-make, last-break shall not be required where inter-

Table 250.122 Minimum Size Equipment Grounding Conductors for Grounding Raceway and Equipment

Rating or Setting of Automatic Overcurrent Device in Circuit Ahead of Equipment, Conduit, etc., Not Exceeding (Amperes)	Size (AWG or kcmil)	
	Copper	Aluminum or Copper-Clad Aluminum*
15	14	12
20	12	10
30	10	8
40	10	8
60	10	8
100	8	6
200	6	4
300	4	2
400	3	1
500	2	1/0
600	1	2/0
800	1/0	3/0
1000	2/0	4/0
1200	3/0	250
1600	4/0	350
2000	250	400
2500	350	600
3000	400	600
4000	500	800
5000	700	1200
6000	800	1200

Note: Where necessary to comply with 250.4(A)(5) or (B)(4), the equipment grounding conductor shall be sized larger than given in this table.

*See installation restrictions in 250.120.

locked equipment, plugs, receptacles, and connectors preclude energization without grounding continuity.

(B) Switches. No automatic cutout or switch shall be placed in the equipment grounding conductor of a premises wiring system unless the opening of the cutout or switch disconnects all sources of energy.

250.126 Identification of Wiring Device Terminals. The terminal for the connection of the equipment grounding conductor shall be identified by one of the following:

- (1) A green, not readily removable terminal screw with a hexagonal head.
- (2) A green, hexagonal, not readily removable terminal nut.
- (3) A green pressure wire connector. If the terminal for the grounding conductor is not visible, the conductor

entrance hole shall be marked with the word *green* or *ground*, the letters *G* or *GR*, a grounding symbol, or otherwise identified by a distinctive green color. If the terminal for the equipment grounding conductor is readily removable, the area adjacent to the terminal shall be similarly marked.

FPN: See FPN Figure 250.126.



FPN Figure 250.126 One Example of a Symbol Used to Identify the Grounding Termination Point for an Equipment Grounding Conductor.

VII. Methods of Equipment Grounding

250.130 Equipment Grounding Conductor Connections.

Equipment grounding conductor connections at the source of separately derived systems shall be made in accordance with 250.30(A)(1) in the *NEC*. Equipment grounding conductor connections at service equipment shall be made as indicated in 250.130(A). For replacement of non-grounding-type receptacles with grounding-type receptacles and for branch-circuit extensions only in existing installations that do not have an equipment grounding conductor in the branch circuit, connections shall be permitted as indicated in 250.130(C).

(A) For Grounded Systems. The connection shall be made by bonding the equipment grounding conductor to the grounded service conductor and the grounding electrode conductor.

(C) Nongrounding Receptacle Replacement or Branch Circuit Extensions. The equipment grounding conductor of a grounding-type receptacle or a branch-circuit extension shall be permitted to be connected to any of the following:

- (1) Any accessible point on the grounding electrode system as described in 250.50
- (2) Any accessible point on the grounding electrode conductor
- (3) The equipment grounding terminal bar within the enclosure where the branch circuit for the receptacle or branch circuit originates
- (4) For grounded systems, the grounded service conductor within the service equipment enclosure

FPN: See 406.3(D) for the use of a ground-fault circuit-interrupting type of receptacle.

250.132 Short Sections of Raceway. Isolated sections of metal raceway or cable armor, where required to be grounded, shall be grounded in accordance with 250.134.

250.134 Equipment Fastened in Place or Connected by Permanent Wiring Methods (Fixed) — Grounding. Unless grounded by connection to the grounded circuit conductor as permitted by 250.32, 250.140, and 250.142, non-current-carrying metal parts of equipment, raceways, and other enclosures, if grounded, shall be grounded by one of the following methods.

(A) Equipment Grounding Conductor Types. By any of the equipment grounding conductors permitted by 250.118.

(B) With Circuit Conductors. By an equipment grounding conductor contained within the same raceway, cable, or otherwise run with the circuit conductors.

Exception No. 1: As provided in 250.130(C), the equipment grounding conductor shall be permitted to be run separately from the circuit conductors.

FPN No. 2: See 400.7 for use of cords for fixed equipment.

250.136 Equipment Considered Effectively Grounded.

Under the conditions specified in 250.136(A), the non-current-carrying metal parts of the equipment shall be considered effectively grounded.

(A) Equipment Secured to Grounded Metal Supports.

Electrical equipment secured to and in electrical contact with a metal rack or structure provided for its support and grounded by one of the means indicated in 250.134. The structural metal frame of a building shall not be used as the required equipment grounding conductor for ac equipment.

250.138 Cord-and-Plug-Connected Equipment.

Non-current-carrying metal parts of cord-and-plug-connected equipment, if grounded, shall be grounded by one of the methods in 250.138(A) or (B).

(A) By Means of an Equipment Grounding Conductor.

By means of an equipment grounding conductor run with the power supply conductors in a cable assembly or flexible cord properly terminated in a grounding-type attachment plug with one fixed grounding contact.

Exception: The grounding contacting pole of grounding-type plug-in ground-fault circuit interrupters shall be permitted to be of the movable, self-restoring type on circuits operating at not over 150 volts between any two conductors or over 150 volts between any conductor and ground.

(B) By Means of a Separate Flexible Wire or Strap.

By means of a separate flexible wire or strap, insulated or bare, protected as well as practicable against physical damage, where part of equipment.

250.140 Frames of Ranges and Clothes Dryers. Frames of electric ranges, wall-mounted ovens, counter-mounted

cooking units, clothes dryers, and outlet or junction boxes that are part of the circuit for these appliances shall be grounded in the manner specified by 250.134 or 250.138.

Exception: For existing branch circuit installations only where an equipment grounding conductor is not present in the outlet or junction box, the frames of electric ranges, wall-mounted ovens, counter-mounted cooking units, clothes dryers, and outlet or junction boxes that are part of the circuit for these appliances shall be permitted to be grounded to the grounded circuit conductor if all the following conditions are met.

- (1) The supply circuit is 120/240-volt, single-phase, 3-wire; or 208Y/120-volt derived from a 3-phase, 4-wire, wye-connected system.
- (2) The grounded conductor is not smaller than 10 AWG copper or 8 AWG aluminum.
- (3) The grounded conductor is insulated, or the grounded conductor is uninsulated and part of a Type SE service-entrance cable and the branch circuit originates at the service equipment.
- (4) Grounding contacts of receptacles furnished as part of the equipment are bonded to the equipment.

250.142 Use of Grounded Circuit Conductor for Grounding Equipment.

(A) Supply-Side Equipment. A grounded circuit conductor shall be permitted to ground non-current-carrying metal parts of equipment, raceways, and other enclosures at any of the following locations:

- (1) On the supply side or within the enclosure of the ac service-disconnecting means
- (2) On the supply side or within the enclosure of the main disconnecting means for separate buildings as provided in 250.32(B)

(B) Load-Side Equipment. Except as permitted in 250.32(B), a grounded circuit conductor shall not be used for grounding non-current-carrying metal parts of equipment on the load side of the service disconnecting means or on the load side of a separately derived system disconnecting means or the overcurrent devices for a separately derived system not having a main disconnecting means.

Exception No. 1: The frames of ranges, wall-mounted ovens, counter-mounted cooking units, and clothes dryers under the conditions permitted for existing installations by 250.140 shall be permitted to be grounded by a grounded circuit conductor.

Exception No. 2: It shall be permissible to ground meter enclosures by connection to the grounded circuit conductor on the load side of the service disconnect where all of the following conditions apply:

- (1) No service ground-fault protection is installed.
- (2) All meter socket enclosures are located immediately adjacent to the service disconnecting means.
- (3) The size of the grounded circuit conductor is not smaller than the size specified in Table 250.122 for equipment grounding conductors.

250.146 Connecting Receptacle Grounding Terminal to Box. An equipment bonding jumper shall be used to connect the grounding terminal of a grounding-type receptacle to a grounded box unless grounded as in 250.146(A) through (C).

(A) Surface Mounted Box. Where the box is mounted on the surface, direct metal-to-metal contact between the device yoke and the box or a contact yoke or device that complies with 250.146(B) shall be permitted to ground the receptacle to the box. At least one of the insulating washers shall be removed from receptacles that do not have a contact yoke or device that complies with 250.146(B) to ensure direct metal-to-metal contact. This provision shall not apply to cover-mounted receptacles unless the box and cover combination are listed as providing satisfactory ground continuity between the box and the receptacle.

(B) Contact Devices or Yokes. Contact devices or yokes designed and listed as self-grounding shall be permitted in conjunction with the supporting screws to establish the grounding circuit between the device yoke and flush-type boxes.

(C) Floor Boxes. Floor boxes designed for and listed as providing satisfactory ground continuity between the box and the device shall be permitted.

250.148 Continuity and Attachment of Equipment Grounding Conductors to Boxes. Where circuit conductors are spliced within a box, or terminated on equipment within or supported by a box, any equipment grounding conductor(s) associated with those circuit conductors shall be spliced or joined within the box or to the box with devices suitable for the use in accordance with 250.148(A) through (E).

(A) Connections. Connections and splices shall be made in accordance with 110.14(B) except that insulation shall not be required.

(B) Grounding Continuity. The arrangement of grounding connections shall be such that the disconnection or the removal of a receptacle, luminaire (fixture), or other device fed from the box does not interfere with or interrupt the grounding continuity.

(C) Metal Boxes. A connection shall be made between the one or more equipment grounding conductors and a metal

box by means of a grounding screw that shall be used for no other purpose or a listed grounding device.

(D) Nonmetallic Boxes. One or more equipment grounding conductors brought into a nonmetallic outlet box shall be arranged such that a connection can be made to any fitting or device in that box requiring grounding.

(E) Solder. Connections depending solely on solder shall not be used.

ARTICLE 280 Surge Arresters

Installations shall conform to the requirements of Article 280 of the 2005 *National Electrical Code* (NFPA 70-2005).

ARTICLE 285 Transient Voltage Surge Suppressors: TVSSs

I. General

285.1 Scope. This article covers general requirements, installation requirements, and connection requirements for transient voltage surge suppressors (TVSSs) permanently installed on premises wiring systems.

285.2 Definition.

Transient Voltage Surge Suppressor (TVSS). A protective device for limiting transient voltages by diverting or limiting surge current; it also prevents continued flow of follow current while remaining capable of repeating these functions.

285.3 Uses Not Permitted. A TVSS device shall not be installed in the following:

- (1) Circuits exceeding 600 volts
- (2) On ungrounded systems, impedance grounded systems, or corner grounded delta systems unless listed specifically for use on these systems
- (3) Where the rating of the TVSS is less than the maximum continuous phase-to-ground power frequency voltage available at the point of application

FPN: For further information on TVSSs, see NEMA LS 1-1992, *Standard for Low Voltage Surge Suppression Devices*.

The selection of a properly rated TVSS is based on criteria such as maximum continuous operating voltage, the magnitude and duration of overvoltages at the suppressor location as affected by phase-to-ground faults, system grounding techniques, and switching surges.

285.4 Number Required. Where used at a point on a circuit, the TVSS shall be connected to each ungrounded conductor.

285.5 Listing. A TVSS shall be a listed device.

285.6 Short Circuit Current Rating. The TVSS shall be marked with a short circuit current rating and shall not be installed at a point on the system where the available fault current is in excess of that rating. This marking requirement shall not apply to receptacles.

II. Installation

285.11 Location. TVSSs shall be permitted to be located indoors or outdoors and shall be made inaccessible to unqualified persons, unless listed for installation in accessible locations.

285.12 Routing of Connections. The conductors used to connect the TVSS to the line or bus and to ground shall not be any longer than necessary and shall avoid unnecessary bends.

III. Connecting Transient Voltage Surge Suppressors

285.21 Connection. Where a TVSS is installed, it shall comply with 285.21(A) through (C).

(A) Location.

(1) Service Supplied Building or Structure. The transient voltage surge suppressor shall be connected on the load side of a service disconnect overcurrent device required in 230.91, unless installed in accordance with 230.82(8) in the *NEC*.

(2) Feeder Supplied Building or Structure. The transient voltage surge suppressor shall be connected on the load side of the first overcurrent device at the building or structure.

Exception to (1) and (2): Where the TVSS is also listed as a surge arrester, the connection shall be as permitted by Article 280 in the NEC.

(3) Separately Derived System. The TVSS shall be connected on the load side of the first overcurrent device in a separately derived system.

(B) Conductor Size. Line and ground connecting conductors shall not be smaller than 14 AWG copper or 12 AWG aluminum.

(C) Connection Between Conductors. A TVSS shall be permitted to be connected between any two conductors — ungrounded conductor(s), grounded conductor, grounding

conductor. The grounded conductor and the grounding conductor shall be interconnected only by the normal operation of the TVSS during a surge.

285.25 Grounding. Grounding conductors shall not be run in metal enclosures unless bonded to both ends of such enclosure.

Chapter 3 Wiring Methods and Materials

ARTICLE 300 Wiring Methods

I. General Requirements

300.1 Scope.

(A) **All Wiring Installations.** This article covers wiring methods for all wiring installations unless modified by other articles.

(B) **Integral Parts of Equipment.** The provisions of this article are not intended to apply to the conductors that form an integral part of equipment, such as motors, controllers, motor control centers, or factory assembled control equipment or listed utilization equipment.

(C) **Metric Designators and Trade Sizes.** Metric designators and trade sizes for conduit, tubing, and associated fittings and accessories shall be as designated in Table 300.1(C).

Table 300.1(C) Metric Designator and Trade Sizes

Metric Designator	Trade Size
12	$\frac{3}{8}$
16	$\frac{1}{2}$
21	$\frac{3}{4}$
27	1
35	$1\frac{1}{4}$
41	$1\frac{1}{2}$
53	2
63	$2\frac{1}{2}$
78	3
91	$3\frac{1}{2}$
103	4
129	5
155	6

Note: The metric designators and trade sizes are for identification purposes only and are not actual dimensions.

300.2 Limitations.

(A) **Voltage.** Wiring methods specified in Chapter 3 shall be used for 600 volts, nominal, or less where not specifically limited in some section of Chapter 3. They shall be permitted for over 600 volts, nominal, where specifically permitted elsewhere in this *Code*.

(B) **Temperature.** Temperature limitation of conductors shall be in accordance with 310.10.

300.3 Conductors.

(A) **Single Conductors.** Single conductors specified in Table 310.13 in the *NEC* shall only be installed where part of a recognized wiring method of Chapter 3.

Exception: Individual conductors shall be permitted where installed as separate overhead conductors in accordance with 225.6.

(B) **Conductors of the Same Circuit.** All conductors of the same circuit and, where used, the grounded conductor and all equipment grounding conductors and bonding conductors shall be contained within the same raceway, auxiliary gutter, cable tray, cablebus assembly, trench, cable, or cord, unless otherwise permitted in accordance with 300.3(B)(1) through (B)(3).

(1) **Paralleled Installations.** Conductors shall be permitted to be run in parallel in accordance with the provisions of 310.4. The requirement to run all circuit conductors within the same raceway, auxiliary gutter, cable tray, trench, cable, or cord shall apply separately to each portion of the paralleled installation, and the equipment grounding conductors shall comply with the provisions of 250.122.

Exception: Conductors installed in nonmetallic raceways run underground shall be permitted to be arranged as isolated phase installations. The raceways shall be installed in close proximity, and the conductors shall comply with the provisions of 300.20(B).

(2) **Grounding and Bonding Conductors.** Equipment grounding conductors shall be permitted to be installed outside a raceway or cable assembly where in accordance with the provisions of 250.130(C) for certain existing installations or in accordance with 250.134(B), Exception No. 2 in the *NEC*, for dc circuits. Equipment bonding conductors shall be permitted to be installed on the outside of raceways in accordance with 250.102(E).

(3) **Nonferrous Wiring Methods.** Conductors in wiring methods with a nonmetallic or other nonmagnetic sheath, where run in different raceways, auxiliary gutters, cable trays, trenches, cables, or cords, shall comply with the provisions of 300.20(B). Conductors in single-conductor Type MI cable with a nonmagnetic sheath shall comply with the provisions of 332.31. Conductors of single-conductor Type MC cable with a nonmagnetic sheath shall comply with the provisions of 330.31, 330.116, and 300.20(B).

(C) Conductors of Different Systems.

(1) **600 Volts, Nominal, or Less.** Conductors of circuits rated 600 volts, nominal, or less, ac circuits, and dc circuits

shall be permitted to occupy the same equipment wiring enclosure, cable, or raceway. All conductors shall have an insulation rating equal to at least the maximum circuit voltage applied to any conductor within the enclosure, cable, or raceway.

Exception: For solar photovoltaic systems in accordance with 690.4(B) in the NEC.

FPN: See 725.55(A) for Class 2 and Class 3 circuit conductors.

300.4 Protection Against Physical Damage. Where subject to physical damage, conductors shall be protected.

(A) Cables and Raceways Through Wood Members.

(1) Bored Holes. In both exposed and concealed locations, where a cable- or raceway-type wiring method is installed through bored holes in joists, rafters, or wood members, holes shall be bored so that the edge of the hole is not less than 32 mm (1¼ in.) from the nearest edge of the wood member. Where this distance cannot be maintained, the cable or raceway shall be protected from penetration by screws or nails by a steel plate or bushing, at least 1.6 mm (⅙ in.) thick, and of appropriate length and width installed to cover the area of the wiring.

Exception No. 1: Steel plates shall not be required to protect rigid metal conduit, intermediate metal conduit, rigid nonmetallic conduit, or electrical metallic tubing.

Exception No. 2: A listed and marked steel plate less than 1.6 mm (⅙ in.) thick that provides equal or better protection against nail or screw penetration shall be permitted.

(2) Notches in Wood. Where there is no objection because of weakening the building structure, in both exposed and concealed locations, cables or raceways shall be permitted to be laid in notches in wood studs, joists, rafters, or other wood members where the cable or raceway at those points is protected against nails or screws by a steel plate at least 1.6 mm (⅙ in.) thick, and of appropriate length and width, installed to cover the area of the wiring. The steel plate shall be installed before the building finish is applied.

Exception No. 1: Steel plates shall not be required to protect rigid metal conduit, intermediate metal conduit, rigid nonmetallic conduit, or electrical metallic tubing.

Exception No. 2: A listed and marked steel plate less than 1.6 mm (⅙ in.) thick that provides equal or better protection against nail or screw penetration shall be permitted.

(B) Nonmetallic-Sheathed Cables and Electrical Nonmetallic Tubing Through Metal Framing Members.

(1) Nonmetallic-Sheathed Cable. In both exposed and concealed locations where nonmetallic-sheathed cables pass

through either factory or field punched, cut, or drilled slots or holes in metal members, the cable shall be protected by listed bushings or listed grommets covering all metal edges that are securely fastened in the opening prior to installation of the cable.

(2) Nonmetallic-Sheathed Cable and Electrical Nonmetallic Tubing. Where nails or screws are likely to penetrate nonmetallic-sheathed cable or electrical nonmetallic tubing, a steel sleeve, steel plate, or steel clip not less than 1.6 mm (⅙ in.) in thickness shall be used to protect the cable or tubing.

Exception: A listed and marked steel plate less than 1.6 mm (⅙ in.) thick that provides equal or better protection against nail or screw penetration shall be permitted.

(C) Cables Through Spaces Behind Panels Designed to Allow Access. Cables or raceway-type wiring methods, installed behind panels designed to allow access, shall be supported according to their applicable articles.

(D) Cables and Raceways Parallel to Framing Members and Furring Strips. In both exposed and concealed locations, where a cable- or raceway-type wiring method is installed parallel to framing members, such as joists, rafters, or studs, or is installed parallel to furring strips, the cable or raceway shall be installed and supported so that the nearest outside surface of the cable or raceway is not less than 32 mm (1¼ in.) from the nearest edge of the framing member or furring strips where nails or screws are likely to penetrate. Where this distance cannot be maintained, the cable or raceway shall be protected from penetration by nails or screws by a steel plate, sleeve, or equivalent at least 1.6 mm (⅙ in.) thick.

Exception No. 1: Steel plates, sleeves, or the equivalent shall not be required to protect rigid metal conduit, intermediate metal conduit, rigid nonmetallic conduit, or electrical metallic tubing.

Exception No. 2: For concealed work in finished buildings, or finished panels for prefabricated buildings where such supporting is impracticable, it shall be permissible to fish the cables between access points.

Exception No. 3: A listed and marked steel plate less than 1.6 mm (⅙ in.) thick that provides equal or better protection against nail or screw penetration shall be permitted.

(E) Cables and Raceways Installed in Shallow Grooves. Cable- or raceway-type wiring methods installed in a groove, to be covered by wallboard, siding, paneling, carpeting, or similar finish, shall be protected by 1.6 mm (⅙ in.) thick steel plate, sleeve, or equivalent or by not less than 32-mm (1¼-in.) free space for the full length of the groove in which the cable or raceway is installed.

Exception No. 1: Steel plates, sleeves, or the equivalent shall not be required to protect rigid metal conduit, intermediate metal conduit, rigid nonmetallic conduit, or electrical metallic tubing.

Exception No. 2: A listed and marked steel plate less than 1.6 mm (1/16 in.) thick that provides equal or better protection against nail or screw penetration shall be permitted.

(F) Insulated Fittings. Where raceways containing ungrounded conductors 4 AWG or larger enter a cabinet, box enclosure, or raceway, the conductors shall be protected by a substantial fitting providing a smoothly rounded insulating surface, unless the conductors are separated from the fitting or raceway by substantial insulating material that is securely fastened in place.

Exception: Where threaded hubs or bosses that are an integral part of a cabinet, box enclosure, or raceway provide a smoothly rounded or flared entry for conductors.

Conduit bushings constructed wholly of insulating material shall not be used to secure a fitting or raceway. The insulating fitting or insulating material shall have a temperature rating not less than the insulation temperature rating of the installed conductors.

300.5 Underground Installations.

(A) Minimum Cover Requirements. Direct-buried cable or conduit or other raceways shall be installed to meet the minimum cover requirements of Table 300.5.

(B) Listing. Cables and insulated conductors installed in enclosures or raceways in underground installations shall be listed for use in wet locations.

(C) Underground Cables Under Buildings. Underground cable installed under a building shall be in a raceway that is extended beyond the outside walls of the building.

(D) Protection from Damage. Direct-buried conductors and cables shall be protected from damage in accordance with 300.5(D)(1) through (D)(4).

(1) Emerging from Grade. Direct-buried conductors and enclosures emerging from grade shall be protected by enclosures or raceways extending from the minimum cover distance below grade required by 300.5(A) to a point at least 2.5 m (8 ft) above finished grade. In no case shall the protection be required to exceed 450 mm (18 in.) below finished grade.

(2) Conductors Entering Buildings. Conductors entering a building shall be protected to the point of entrance.

(3) Service Conductors. Underground service conductors that are not encased in concrete and that are buried 450

mm (18 in.) or more below grade shall have their location identified by a warning ribbon that is placed in the trench at least 300 mm (12 in.) above the underground installation.

(4) Enclosure or Raceway Damage. Where the enclosure or raceway is subject to physical damage, the conductors shall be installed in rigid metal conduit, intermediate metal conduit, Schedule 80 rigid nonmetallic conduit, or equivalent.

(E) Splices and Taps. Direct-buried conductors or cables shall be permitted to be spliced or tapped without the use of splice boxes. The splices or taps shall be made in accordance with 110.14(B).

(F) Backfill. Backfill that contains large rocks, paving materials, cinders, large or sharply angular substances, or corrosive material shall not be placed in an excavation where materials may damage raceways, cables, or other substructures or prevent adequate compaction of fill or contribute to corrosion of raceways, cables, or other substructures.

Where necessary to prevent physical damage to the raceway or cable, protection shall be provided in the form of granular or selected material, suitable running boards, suitable sleeves, or other approved means.

(G) Raceway Seals. Conduits or raceways through which moisture may contact live parts shall be sealed or plugged at either or both ends.

FPN: Presence of hazardous gases or vapors may also necessitate sealing of underground conduits or raceways entering buildings.

(H) Bushing. A bushing, or terminal fitting, with an integral bushed opening shall be used at the end of a conduit or other raceway that terminates underground where the conductors or cables emerge as a direct burial wiring method. A seal incorporating the physical protection characteristics of a bushing shall be permitted to be used in lieu of a bushing.

(I) Conductors of the Same Circuit. All conductors of the same circuit and, where used, the grounded conductor and all equipment grounding conductors shall be installed in the same raceway or cable or shall be installed in close proximity in the same trench.

Exception No. 1: Conductors in parallel in raceways or cables shall be permitted, but each raceway or cable shall contain all conductors of the same circuit including grounding conductors.

Exception No. 2: Isolated phase, polarity, grounded conductor, and equipment grounding and bonding conductor installations shall be permitted in nonmetallic raceways or cables with a nonmetallic covering or nonmagnetic sheath in close

Table 300.5 Minimum Cover Requirements, 0 to 600 Volts, Nominal, Burial in Millimeters (Inches)

Location of Wiring Method or Circuit	Type of Wiring Method or Circuit									
	Column 1 Direct Burial Cables or Conductors		Column 2 Rigid Metal Conduit or Intermediate Metal Conduit		Column 3 Nonmetallic Raceways Listed for Direct Burial Without Concrete Encasement or Other Approved Raceways		Column 4 Residential Branch Circuits Rated 120 Volts or Less with GFCI Protection and Maximum Overcurrent Protection of 20 Amperes		Column 5 Circuits for Control of Irrigation and Landscape Lighting Limited to Not More Than 30 Volts and Installed with Type UF or in Other Identified Cable or Raceway	
	mm	in.	mm	in.	mm	in.	mm	in.	mm	in.
All locations not specified below	600	24	150	6	450	18	300	12	150	6
In trench below 50-mm (2-in.) thick concrete or equivalent	450	18	150	6	300	12	150	6	150	6
Under a building	0	0	0	0	0	0	0	0	0	0
	(in raceway only)						(in raceway only)		(in raceway only)	
Under minimum of 102-mm (4-in.) thick concrete exterior slab with no vehicular traffic and the slab extending not less than 152 mm (6 in.) beyond the underground installation	450	18	100	4	100	4	150	6	150	6
							(direct burial)			
							100	4		
							(in raceway)			
Under streets, highways, roads, alleys, driveways, and parking lots	600	24	600	24	600	24	600	24	600	24
One- and two-family dwelling driveways and outdoor parking areas, and used only for dwelling-related purposes	450	18	450	18	450	18	300	12	450	18
In or under airport runways, including adjacent areas where trespassing prohibited	450	18	450	18	450	18	450	18	450	18

Notes:

- Cover is defined as the shortest distance in millimeters (inches) measured between a point on the top surface of any direct-buried conductor, cable, conduit, or other raceway and the top surface of finished grade, concrete, or similar cover.
- Raceways approved for burial only where concrete encased shall require concrete envelope not less than 50 mm (2 in.) thick.
- Lesser depths shall be permitted where cables and conductors rise for terminations or splices or where access is otherwise required.
- Where one of the wiring method types listed in Columns 1–3 is used for one of the circuit types in Columns 4 and 5, the shallowest depth of burial shall be permitted.
- Where solid rock prevents compliance with the cover depths specified in this table, the wiring shall be installed in metal or nonmetallic raceway permitted for direct burial. The raceways shall be covered by a minimum of 50 mm (2 in.) of concrete extending down to rock.

proximity where conductors are paralleled as permitted in 310.4, and where the conditions of 300.20(B) are met.

(J) Ground Movement. Where direct-buried conductors, raceways, or cables are subject to movement by settlement or frost, direct-buried conductors, raceways, or cables shall be arranged so as to prevent damage to the enclosed conductors or to equipment connected to the raceways.

FPN: This section recognizes “S” loops in underground direct burial to raceway transitions, expansion fittings in raceway risers to fixed equipment, and, generally, the provision of flexible connections to equipment subject to settlement or frost heaves.

(K) Directional Boring. Cables or raceways installed using directional boring equipment shall be approved for the purpose.

300.6 Protection Against Corrosion and Deterioration. Raceways, cable trays, cablebus, auxiliary gutters, cable armor, boxes, cable sheathing, cabinets, elbows, couplings, fittings, supports, and support hardware shall be of materials suitable for the environment in which they are to be installed.

(A) Ferrous Metal Equipment. Ferrous metal raceways, cable trays, cablebus, auxiliary gutters, cable armor, boxes, cable sheathing, cabinets, metal elbows, couplings, nipples, fittings, supports, and support hardware shall be suitably protected against corrosion inside and outside (except threads at joints) by a coating of approved corrosion-resistant material. Where corrosion protection is necessary and the conduit is threaded in the field, the threads shall be coated with an approved electrically conductive, corrosion-resistant compound.

Exception: Stainless steel shall not be required to have protective coatings.

(1) Protected from Corrosion Solely by Enamel. Where protected from corrosion solely by enamel, ferrous metal raceways, cable trays, cablebus, auxiliary gutters, cable armor, boxes, cable sheathing, cabinets, metal elbows, couplings, nipples, fittings, supports, and support hardware shall not be used outdoors or in wet locations as described in 300.6(D) in the *NEC*.

(2) Organic Coatings on Boxes or Cabinets. Where boxes or cabinets have an approved system of organic coatings and are marked “Raintight,” “Rainproof,” or “Outdoor Type,” they shall be permitted outdoors.

(3) In Concrete or in Direct Contact with the Earth. Ferrous metal raceways, cable armor, boxes, cable sheathing, cabinets, elbows, couplings, nipples, fittings, supports, and support hardware shall be permitted to be installed in con-

crete or in direct contact with the earth, or in areas subject to severe corrosive influences where made of material approved for the condition, or where provided with corrosion protection approved for the condition.

(B) Non-Ferrous Metal Equipment. Non-ferrous raceways, cable trays, cablebus, auxiliary gutters, cable armor, boxes, cable sheathing, cabinets, elbows, couplings, nipples, fittings, supports, and support hardware embedded or encased in concrete or in direct contact with the earth shall be provided with supplementary corrosion protection.

(C) Nonmetallic Equipment. Nonmetallic raceways, cable trays, cablebus, auxiliary gutters, boxes, cables with a nonmetallic outer jacket and internal metal armor or jacket, cable sheathing, cabinets, elbows, couplings, nipples, fittings, supports, and support hardware shall be made of material approved for the condition and shall comply with (C)(1) and (C)(2) as applicable to the specific installation.

(1) Exposed to Sunlight. Where exposed to sunlight, the materials shall be listed as sunlight resistant or shall be identified as sunlight resistant.

(2) Chemical Exposure. Where subject to exposure to chemical solvents, vapors, splashing, or immersion, materials or coatings shall either be inherently resistant to chemicals based on its listing or be identified for the specific chemical reagent.

300.10 Electrical Continuity of Metal Raceways and Enclosures. Metal raceways, cable armor, and other metal enclosures for conductors shall be metallically joined together into a continuous electric conductor and shall be connected to all boxes, fittings, and cabinets so as to provide effective electrical continuity. Unless specifically permitted elsewhere in this *Code*, raceways and cable assemblies shall be mechanically secured to boxes, fittings, cabinets, and other enclosures.

Exception No. 1: Short sections of raceways used to provide support or protection of cable assemblies from physical damage shall not be required to be made electrically continuous.

300.11 Securing and Supporting.

(A) Secured in Place. Raceways, cable assemblies, boxes, cabinets, and fittings shall be securely fastened in place. Support wires that do not provide secure support shall not be permitted as the sole support. Support wires and associated fittings that provide secure support and that are installed in addition to the ceiling grid support wires shall be permitted as the sole support. Where independent support wires are used, they shall be secured at both ends. Cables and raceways shall not be supported by ceiling grids.

(1) Fire-Rated Assemblies. Wiring located within the cavity of a fire-rated floor-ceiling or roof-ceiling assembly shall not be secured to, or supported by, the ceiling assembly, including the ceiling support wires. An independent means of secure support shall be provided and shall be permitted to be attached to the assembly. Where independent support wires are used, they shall be distinguishable by color, tagging, or other effective means from those that are part of the fire-rated design.

Exception: The ceiling support system shall be permitted to support wiring and equipment that have been tested as part of the fire-rated assembly.

FPN: One method of determining fire rating is testing in accordance with NFPA 251-1999, *Standard Methods of Tests of Fire Endurance of Building Construction and Materials*.

(2) Non-Fire-Rated Assemblies. Wiring located within the cavity of a non-fire-rated floor-ceiling or roof-ceiling assembly shall not be secured to, or supported by, the ceiling assembly, including the ceiling support wires. An independent means of secure support shall be provided.

Exception: The ceiling support system shall be permitted to support branch-circuit wiring and associated equipment where installed in accordance with the ceiling system manufacturer's instructions.

(B) Raceways Used as Means of Support. Raceways shall be used only as a means of support for other raceways, cables, or nonelectrical equipment under any of the following conditions:

- (1) Where the raceway or means of support is identified for the purpose
- (2) Where the raceway contains power supply conductors for electrically controlled equipment and is used to support Class 2 circuit conductors or cables that are solely for the purpose of connection to the equipment control circuits
- (3) Where the raceway is used to support boxes or conduit bodies in accordance with 314.23 or to support luminaires (fixtures) in accordance with 410.16(F)

(C) Cables Not Used as Means of Support. Cable wiring methods shall not be used as a means of support for other cables, raceways, or nonelectrical equipment.

300.12 Mechanical Continuity — Raceways and Cables. Metal or nonmetallic raceways, cable armors, and cable sheaths shall be continuous between cabinets, boxes, fittings, or other enclosures or outlets.

Exception: Short sections of raceways used to provide support or protection of cable assemblies from physical damage shall not be required to be mechanically continuous.

300.13 Mechanical and Electrical Continuity — Conductors.

(A) General. Conductors in raceways shall be continuous between outlets, boxes, devices, and so forth. There shall be no splice or tap within a raceway unless permitted by 300.15; and 368.56(A); 376.56; 378.56; 384.56; 386.56; 388.56; or 390.6 in the *NEC*.

(B) Device Removal. In multiwire branch circuits, the continuity of a grounded conductor shall not depend on device connections such as lampholders, receptacles, and so forth, where the removal of such devices would interrupt the continuity.

300.14 Length of Free Conductors at Outlets, Junctions, and Switch Points. At least 150 mm (6 in.) of free conductor, measured from the point in the box where it emerges from its raceway or cable sheath, shall be left at each outlet, junction, and switch point for splices or the connection of luminaires (fixtures) or devices. Where the opening to an outlet, junction, or switch point is less than 200 mm (8 in.) in any dimension, each conductor shall be long enough to extend at least 75 mm (3 in.) outside the opening.

Exception: Conductors that are not spliced or terminated at the outlet, junction, or switch point shall not be required to comply with 300.14.

300.15 Boxes, Conduit Bodies, or Fittings — Where Required. A box shall be installed at each outlet and switch point for concealed knob-and-tube wiring.

Fittings and connectors shall be used only with the specific wiring methods for which they are designed and listed.

Where the wiring method is conduit, tubing, Type AC cable, Type MC cable, Type MI cable, nonmetallic-sheathed cable, or other cables, a box or conduit body shall be installed at each conductor splice point, outlet point, switch point, junction point, termination point, or pull point, unless otherwise permitted in 300.15(A), (B), (C), (E), (F), (G), (H), (I), (J), (K), and (L).

(A) Wiring Methods with Interior Access. A box or conduit body shall not be required for each splice, junction, switch, pull, termination, or outlet points in wiring methods with removable covers, such as wireways, multioutlet assemblies, auxiliary gutters, and surface raceways. The covers shall be accessible after installation.

(B) Equipment. An integral junction box or wiring compartment as part of approved equipment shall be permitted in lieu of a box.

(C) Protection. A box or conduit body shall not be required where cables enter or exit from conduit or tubing that is

used to provide cable support or protection against physical damage. A fitting shall be provided on the end(s) of the conduit or tubing to protect the cable from abrasion.

(E) Integral Enclosure. A wiring device with integral enclosure identified for the use, having brackets that securely fasten the device to walls or ceilings of conventional on-site frame construction, for use with nonmetallic-sheathed cable, shall be permitted in lieu of a box or conduit body.

FPN: See 334.30(C).

(F) Fitting. A fitting identified for the use shall be permitted in lieu of a box or conduit body where conductors are not spliced or terminated within the fitting. The fitting shall be accessible after installation.

(G) Direct-Buried Conductors. As permitted in 300.5(E), a box or conduit body shall not be required for splices and taps in direct-buried conductors and cables.

(H) Insulated Devices. As permitted in 334.40(B), a box or conduit body shall not be required for insulated devices supplied by nonmetallic-sheathed cable.

(I) Enclosures. A box or conduit body shall not be required where a splice, switch, terminal, or pull point is in a cabinet or cutout box, in an enclosure for a switch or overcurrent device as permitted in 312.8, in a motor controller as permitted in 430.10(A) in the *NEC*, or in a motor control center.

(J) Luminaires (Fixtures). A box or conduit body shall not be required where a luminaire (fixture) is used as a raceway as permitted in 410.31 and 410.32.

(K) Embedded. A box or conduit body shall not be required for splices where conductors are embedded as permitted in 424.40, and 424.41(D).

(L) Handhole Enclosures. Where accessible only to qualified persons, a box or conduit body shall not be required for conductors in handhole enclosures, except where connecting to electrical equipment. The installation shall comply with the provisions of 314.30 for handhole enclosures.

300.17 Number and Size of Conductors in Raceway. The number and size of conductors in any raceway shall not be more than will permit dissipation of the heat and ready installation or withdrawal of the conductors without damage to the conductors or to their insulation.

FPN: See the following sections of this *Code*: intermediate metal conduit, 342.22; rigid metal conduit, 344.22; flexible metal conduit, 348.22; liquidtight flexible metal conduit, 350.22; rigid nonmetallic conduit, 352.22; liquidtight nonmetallic flexible conduit, 356.22; electrical metallic tubing, 358.22; electrical nonmetallic tubing, 362.22; Class 1, Class 2, and Class 3 circuits, Article 725; and fire alarm circuits, Article 760.

300.18 Raceway Installations.

(A) Complete Runs. Raceways, other than busways or exposed raceways having hinged or removable covers, shall be installed complete between outlet, junction, or splicing points prior to the installation of conductors. Where required to facilitate the installation of utilization equipment, the raceway shall be permitted to be initially installed without a terminating connection at the equipment. Prewired raceway assemblies shall be permitted only where specifically permitted in this *Code* for the applicable wiring method.

Exception: Short sections of raceways used to contain conductors or cable assemblies for protection from physical damage shall not be required to be installed complete between outlet, junction, or splicing points.

(B) Welding. Metal raceways shall not be supported, terminated, or connected by welding to the raceway unless specifically designed to be or otherwise specifically permitted to be in this *Code*.

300.20 Induced Currents in Metal Enclosures or Metal Raceways.

(A) Conductors Grouped Together. Where conductors carrying alternating current are installed in metal enclosures or metal raceways, they shall be arranged so as to avoid heating the surrounding metal by induction. To accomplish this, all phase conductors and, where used, the grounded conductor and all equipment grounding conductors shall be grouped together.

Exception No. 1: Equipment grounding conductors for certain existing installations shall be permitted to be installed separate from their associated circuit conductors where run in accordance with the provisions of 250.130(C).

(B) Individual Conductors. Where a single conductor carrying alternating current passes through metal with magnetic properties, the inductive effect shall be minimized by (1) cutting slots in the metal between the individual holes through which the individual conductors pass or (2) passing all the conductors in the circuit through an insulating wall sufficiently large for all of the conductors of the circuit.

FPN: Because aluminum is not a magnetic metal, there will be no heating due to hysteresis; however, induced currents will be present. They will not be of sufficient magnitude to require grouping of conductors or special treatment in passing conductors through aluminum wall sections.

300.21 Spread of Fire or Products of Combustion. Electrical installations in hollow spaces, vertical shafts, and ventilation or air-handling ducts shall be made so that the possible spread of fire or products of combustion will not be substantially increased. Openings around electrical penetrations through fire-resistant-rated walls, partitions, floors,

or ceilings shall be firestopped using approved methods to maintain the fire resistance rating.

FPN: Directories of electrical construction materials published by qualified testing laboratories contain many listing installation restrictions necessary to maintain the fire-resistive rating of assemblies where penetrations or openings are made. Building codes also contain restrictions on membrane penetrations on opposite sides of a fire-resistance-rated wall assembly. An example is the 600-mm (24-in.) minimum horizontal separation that usually applies between boxes installed on opposite sides of the wall. Assistance in complying with 300.21 can be found in building codes, fire resistance directories, and product listings.

300.22 Wiring in Ducts, Plenums, and Other Air-Handling Spaces. The provisions of this section apply to the installation and uses of electric wiring and equipment in ducts, plenums, and other air-handling spaces.

FPN: See Article 424, Part VI, for duct heaters.

(B) Ducts or Plenums Used for Environmental Air. Only wiring methods consisting of Type MI cable, Type MC cable employing a smooth or corrugated impervious metal sheath without an overall nonmetallic covering, electrical metallic tubing, flexible metallic tubing, intermediate metal conduit, or rigid metal conduit without an overall nonmetallic covering shall be installed in ducts or plenums specifically fabricated to transport environmental air. Flexible metal conduit shall be permitted, in lengths not to exceed 1.2 m (4 ft), to connect physically adjustable equipment and devices permitted to be in these ducts and plenum chambers. The connectors used with flexible metal conduit shall effectively close any openings in the connection. Equipment and devices shall be permitted within such ducts or plenum chambers only if necessary for their direct action upon, or sensing of, the contained air. Where equipment or devices are installed and illumination is necessary to facilitate maintenance and repair, enclosed gasketed-type luminaires (fixtures) shall be permitted.

(C) Other Space Used for Environmental Air. This section applies to space used for environmental air-handling purposes other than ducts and plenums as specified in 300.22(A) in the *NEC* and 300.22 (B). It does not include habitable rooms or areas of buildings, the prime purpose of which is not air handling.

FPN: The space over a hung ceiling used for environmental air-handling purposes is an example of the type of other space to which this section applies.

Exception: This section shall not apply to the joist or stud spaces of dwelling units where the wiring passes through such spaces perpendicular to the long dimension of such spaces.

(1) Wiring Methods. The wiring methods for such other space shall be limited to totally enclosed, nonventilated, insulated busway having no provisions for plug-in connections, Type MI cable, Type MC cable without an overall nonmetallic covering, Type AC cable, or other factory-assembled multiconductor control or power cable that is specifically listed for the use, or listed prefabricated cable assemblies of metallic manufactured wiring systems without nonmetallic sheath. Other types of cables and conductors shall be installed in electrical metallic tubing, flexible metallic tubing, intermediate metal conduit, rigid metal conduit without an overall nonmetallic covering, flexible metal conduit, or, where accessible, surface metal raceway or metal wireway with metal covers or solid bottom metal cable tray with solid metal covers.

(2) Equipment. Electrical equipment with a metal enclosure, or with a nonmetallic enclosure listed for the use and having adequate fire-resistant and low-smoke-producing characteristics, and associated wiring material suitable for the ambient temperature shall be permitted to be installed in such other space unless prohibited elsewhere in this *Code*.

Exception: Integral fan systems shall be permitted where specifically identified for such use.

300.23 Panels Designed to Allow Access. Cables, raceways, and equipment installed behind panels designed to allow access, including suspended ceiling panels, shall be arranged and secured so as to allow the removal of panels and access to the equipment.

ARTICLE 310 Conductors for General Wiring

310.1 Scope. This article covers general requirements for conductors and their type designations, insulations, markings, mechanical strengths, ampacity ratings, and uses. These requirements do not apply to conductors that form an integral part of equipment, such as motors, motor controllers, and similar equipment, or to conductors specifically provided for elsewhere in this *Code*.

FPN: For flexible cords and cables, see Article 400. For fixture wires, see Article 402 in the *NEC*.

310.2 Conductors.

(A) Insulated. Conductors shall be insulated.

Exception: Where covered or bare conductors are specifically permitted elsewhere in this Code.

(B) Conductor Material. Conductors in this article shall be of aluminum, copper-clad aluminum, or copper unless otherwise specified.

310.3 Stranded Conductors. Where installed in raceways, conductors of size 8 AWG and larger shall be stranded.

Exception: As permitted or required elsewhere in this Code.

310.4 Conductors in Parallel. Aluminum, copper-clad aluminum, or copper conductors of size 1/0 AWG and larger, comprising each phase, polarity, neutral, or grounded circuit conductor, shall be permitted to be connected in parallel (electrically joined at both ends).

The paralleled conductors in each phase, polarity, neutral, or grounded circuit conductor shall comply with all of the following:

- (1) Be the same length
- (2) Have the same conductor material
- (3) Be the same size in circular mil area
- (4) Have the same insulation type
- (5) Be terminated in the same manner

Where run in separate raceways or cables, the raceways or cables shall have the same physical characteristics. Where conductors are in separate raceways or cables, the same number of conductors shall be used in each raceway or cable. Conductors of one phase, polarity, neutral, or grounded circuit conductor shall not be required to have the same physical characteristics as those of another phase, polarity, neutral, or grounded circuit conductor to achieve balance.

FPN: Differences in inductive reactance and unequal division of current can be minimized by choice of materials, methods of construction, and orientation of conductors.

Where equipment grounding conductors are used with conductors in parallel, they shall comply with the requirements of this section except that they shall be sized in accordance with 250.122.

Conductors installed in parallel shall comply with the provisions of 310.15(B)(2)(a).

310.5 Minimum Size of Conductors. The minimum size of conductors shall be as shown in Table 310.5, except as permitted elsewhere in this Code.

Table 310.5 Minimum Size of Conductors

Conductor Voltage Rating (Volts)	Minimum Conductor Size (AWG)	
	Copper	Aluminum or Copper-Clad Aluminum
0-2000	14	12

310.7 Direct Burial Conductors. Conductors used for direct burial applications shall be of a type identified for such use.

FPN: No. 1: See 300.5 for installation requirements for conductors rated 600 volts or less.

310.8 Locations.

(A) Dry Locations. Insulated conductors and cables used in dry locations shall be any of the types identified in this Code.

(B) Dry and Damp Locations. Insulated conductors and cables used in dry and damp locations shall be Types FEP, FEPB, MTW, PFA, RHH, RHW, RHW-2, SA, THHN, THW, THW-2, THHW, THHW-2, THWN, THWN-2, TW, XHH, XHHW, XHHW-2, Z, or ZW.

(C) Wet Locations. Insulated conductors and cables used in wet locations shall be

- (1) Moisture-impervious metal-sheathed;
- (2) Types MTW, RHW, RHW-2, TW, THW, THW-2, THHW, THHW-2, THWN, THWN-2, XHHW, XHHW-2, ZW; or
- (3) Of a type listed for use in wet locations.

(D) Locations Exposed to Direct Sunlight. Insulated conductors or cables used where exposed to direct rays of the sun shall comply with one of the following:

- (1) Cables listed, or listed and marked, as being sunlight resistant
- (2) Conductors listed, or listed and marked, as being sunlight resistant
- (3) Covered with insulating material, such as tape or sleeving, that is listed, or listed and marked, as being sunlight resistant

310.10 Temperature Limitation of Conductors. No conductor shall be used in such a manner that its operating temperature exceeds that designated for the type of insulated conductor involved. In no case shall conductors be associated together in such a way, with respect to type of circuit, the wiring method employed, or the number of conductors, that the limiting temperature of any conductor is exceeded.

FPN: No. 1: The temperature rating of a conductor (see Table 310.13 in the NEC) is the maximum temperature, at any location along its length, that the conductor can withstand over a prolonged time period without serious degradation. The allowable ampacity tables, the ampacity tables of Article 310 and the ampacity tables of Annex B in the NEC, the correction factors at the bottom of these tables, and the notes to the tables provide guidance for coordinating conductor sizes, types, allowable ampacities, ambient temperatures, and number of associated conductors.

The principal determinants of operating temperature are as follows:

- (1) Ambient temperature — ambient temperature may vary along the conductor length as well as from time to time.
- (2) Heat generated internally in the conductor as the result of load current flow, including fundamental and harmonic currents.
- (3) The rate at which generated heat dissipates into the ambient medium. Thermal insulation that covers or surrounds conductors affects the rate of heat dissipation.
- (4) Adjacent load-carrying conductors — adjacent conductors have the dual effect of raising the ambient temperature and impeding heat dissipation.

FPN: No. 2: Conductors installed in conduit exposed to direct sunlight in close proximity to rooftops have been shown, under certain conditions, to experience a temperature rise of 17°C (30°F) above ambient temperature on which the ampacity is based.

310.11 Marking.

(A) Required Information. All conductors and cables shall be marked to indicate the following information, using the applicable method described in 310.11(B):

- (1) The maximum rated voltage
- (2) The proper type letter or letters for the type of wire or cable as specified elsewhere in this *Code*
- (3) The manufacturer's name, trademark, or other distinctive marking by which the organization responsible for the product can be readily identified
- (4) The AWG size or circular mil area

FPN: See Conductor Properties, Table 8 of Chapter 9, for conductor area expressed in SI units for conductor sizes specified in AWG or circular mil area.

- (5) Cable assemblies where the neutral conductor is smaller than the ungrounded conductors shall be so marked

(B) Method of Marking.

(1) Surface Marking. The following conductors and cables shall be durably marked on the surface. The AWG size or circular mil area shall be repeated at intervals not exceeding 610 mm (24 in.). All other markings shall be repeated at intervals not exceeding 1.0 m (40 in.).

- (1) Single-conductor and multiconductor rubber- and thermoplastic-insulated wire and cable
- (2) Nonmetallic-sheathed cable
- (3) Service-entrance cable
- (4) Underground feeder and branch-circuit cable

(2) Marker Tape. Metal-covered multiconductor cables shall employ a marker tape located within the cable and running for its complete length.

Exception No. 2: Type AC cable.

FPN: Included in the group of metal-covered cables are Type AC cable (Article 320), Type MC cable (Article 330), and lead-sheathed cable.

(3) Tag Marking. The following cable shall be marked by means of a printed tag attached to the coil, reel, or carton:

- (4) Type AC cable

(4) Optional Marking of Wire Size. The information required in 310.11(A)(4) shall be permitted to be marked on the surface of the individual insulated conductors for the following multiconductor cables:

- (1) Type MC cable
- (5) Power-limited fire alarm cable

310.12 Conductor Identification.

(A) Grounded Conductors. Insulated or covered grounded conductors shall be identified in accordance with 200.6.

(B) Equipment Grounding Conductors. Equipment grounding conductors shall be in accordance with 250.119.

(C) Ungrounded Conductors. Conductors that are intended for use as ungrounded conductors, whether used as a single conductor or in multiconductor cables, shall be finished to be clearly distinguishable from grounded and grounding conductors. Distinguishing markings shall not conflict in any manner with the surface markings required by 310.11(B)(1). Branch-circuit ungrounded conductors shall be identified in accordance with 210.5(C) in the *NEC*. Feeders shall be identified in accordance with 215.12.

Exception: Conductor identification shall be permitted in accordance with 200.7.

310.14 Aluminum Conductor Material. Solid aluminum conductors 8, 10, and 12 AWG shall be made of an AA-8000 series electrical grade aluminum alloy conductor material. Stranded aluminum conductors 8 AWG through 1000 kcmil marked as Type RHH, RHW, XHHW, THW, THHW, THWN, THHN, service-entrance Type SE Style U and SE Style R shall be made of an AA-8000 series electrical grade aluminum alloy conductor material.

310.15 Ampacities for Conductors Rated 0–2000 Volts.

(A) General.

(1) Tables. Ampacities for conductors shall be permitted to be determined by tables as provided in 310.15(B).

FPN: No. 1: Ampacities provided by this section do not take voltage drop into consideration. See 210.19(A), FPN No. 4, for branch circuits and 215.2(A), FPN No. 2, for feeders.

(2) Selection of Ampacity. Where more than one calculated or tabulated ampacity could apply for a given circuit length, the lowest value shall be used.

Exception: Where two different ampacities apply to adjacent portions of a circuit, the higher ampacity shall be permitted to be used beyond the point of transition, a distance equal to 3.0 m (10 ft) or 10 percent of the circuit length figured at the higher ampacity, whichever is less.

FPN: See 110.14(C) for conductor temperature limitations due to termination provisions.

(B) Tables. Ampacities for conductors rated 0 to 2000 volts shall be as specified in the Allowable Ampacity Table 310.16 as modified by (B)(1), (B)(2), (B)(5), and (B)(6).

(1) General. For explanation of type letters used in tables and for recognized sizes of conductors for the various conductor insulations, see 310.13 in the *NEC*. For installation requirements, see 310.1 through 310.5; 310.7, 310.8, and 310.10 and the various articles of this *Code*. For flexible cords, see Table 400.4, Table 400.5(A), and Table 400.5(B) in the *NEC*.

(2) Adjustment Factors.

(a) More Than Three Current-Carrying Conductors in a Raceway or Cable. Where the number of current-carrying conductors in a raceway or cable exceeds three, or where single conductors or multiconductor cables are stacked or bundled longer than 600 mm (24 in.) without maintaining spacing and are not installed in raceways, the allowable ampacity of each conductor shall be reduced as shown in Table 310.15(B)(2)(a). Each current-carrying conductor of a paralleled set of conductors shall be counted as a current-carrying conductor.

Exception No. 3: Derating factors shall not apply to conductors in nipples having a length not exceeding 600 mm (24 in.).

Table 310.15(B)(2)(a) Adjustment Factors for More Than Three Current-Carrying Conductors in a Raceway or Cable

Number of Current-Carrying Conductors	Percent of Values in Table 310.16 as Adjusted for Ambient Temperature if Necessary
4-6	80
7-9	70
10-20	50
21-30	45
31-40	40
41 and above	35

Exception No. 4: Derating factors shall not apply to underground conductors entering or leaving an outdoor trench if those conductors have physical protection in the form of rigid metal conduit, intermediate metal conduit, or rigid nonmetallic conduit having a length not exceeding 3.05 m (10 ft) and if the number of conductors does not exceed four.

Exception No. 5: Adjustment factors shall not apply to Type AC cable or to Type MC cable without an overall outer jacket under the following conditions:

- (1) Each cable has not more than three current-carrying conductors.
- (2) The conductors are 12 AWG copper.
- (3) Not more than 20 current-carrying conductors are bundled, stacked, or supported on “bridle rings.”

A 60 percent adjustment factor shall be applied where the current-carrying conductors in these cables that are stacked or bundled longer than 600 mm (24 in.) without maintaining spacing exceeds 20.

(5) Grounding or Bonding Conductor. A grounding or bonding conductor shall not be counted when applying the provisions of 310.15(B)(2)(a).

(6) 120/240-Volt, 3-Wire, Single-Phase Dwelling Services and Feeders. For individual dwelling units of one family, two-family, and multifamily dwellings, conductors, as listed in Table 310.15(B)(6), shall be permitted as 120/240-volt, 3-wire, single-phase service-entrance conductors, service lateral conductors, and feeder conductors that serve as the main power feeder to each dwelling unit and are installed

Table 310.15(B)(6) Conductor Types and Sizes for 120/240-Volt, 3-Wire, Single-Phase Dwelling Services and Feeders. Conductor Types RHH, RHW, RHW-2, THHN, THHW, THW, THW-2, THWN, THWN-2, XHHW, XHHW-2, SE, USE, USE-2

Conductor (AWG or kcmil)		
Copper	Aluminum or Copper-Clad Aluminum	Service or Feeder Rating (Amperes)
4	2	100
3	1	110
2	1/0	125
1	2/0	150
1/0	3/0	175
2/0	4/0	200
3/0	250	225
4/0	300	250
250	350	300
350	500	350
400	600	400

Table 310.16 Allowable Ampacities of Insulated Conductors Rated 0 Through 2000 Volts, 60°C Through 90°C (140°F Through 194°F), Not More Than Three Current-Carrying Conductors in Raceway, Cable, or Earth (Directly Buried), Based on Ambient Temperature of 30°C (86°F)

Size AWG or kcmil	Temperature Rating of Conductor (See Table 310.13.)						Size AWG or kcmil
	60°C (140°F)	75°C (167°F)	90°C (194°F)	60°C (140°F)	75°C (167°F)	90°C (194°F)	
	Types TW, UF	Types RHW, THHW, THW, THWN, XHHW, USE, ZW	Types TBS, SA, SIS, FEP, FEPB, MI, RHH, RHW-2, THHN, THHW, THW-2, THWN-2, USE-2, XHH, XHHW, XHHW-2, ZW-2	Types TW, UF	Types RHW, THHW, THW, THWN, XHHW, USE	Types TBS, SA, SIS, THHN, THHW, THW-2, THWN-2, RHH, RHW-2, USE-2, XHH, XHHW, XHHW-2, ZW-2	
COPPER			ALUMINUM OR COPPER-CLAD ALUMINUM				
18	—	—	14	—	—	—	—
16	—	—	18	—	—	—	—
14*	20	20	25	—	—	—	—
12*	25	25	30	20	20	25	12*
10*	30	35	40	25	30	35	10*
8	40	50	55	30	40	45	8
6	55	65	75	40	50	60	6
4	70	85	95	55	65	75	4
3	85	100	110	65	75	85	3
2	95	115	130	75	90	100	2
1	110	130	150	85	100	115	1
1/0	125	150	170	100	120	135	1/0
2/0	145	175	195	115	135	150	2/0
3/0	165	200	225	130	155	175	3/0
4/0	195	230	260	150	180	205	4/0
250	215	255	290	170	205	230	250
300	240	285	320	190	230	255	300
350	260	310	350	210	250	280	350
400	280	335	380	225	270	305	400
500	320	380	430	260	310	350	500
600	355	420	475	285	340	385	600
700	385	460	520	310	375	420	700
750	400	475	535	320	385	435	750
800	410	490	555	330	395	450	800
900	435	520	585	355	425	480	900
1000	455	545	615	375	445	500	1000
1250	495	590	665	405	485	545	1250
1500	520	625	705	435	520	585	1500
1750	545	650	735	455	545	615	1750
2000	560	665	750	470	560	630	2000

CORRECTION FACTORS

Ambient Temp. (°C)	For ambient temperatures other than 30°C (86°F), multiply the allowable ampacities shown above by the appropriate factor shown below.						Ambient Temp. (°F)
21-25	1.08	1.05	1.04	1.08	1.05	1.04	70-77
26-30	1.00	1.00	1.00	1.00	1.00	1.00	78-86
31-35	0.91	0.94	0.96	0.91	0.94	0.96	87-95
36-40	0.82	0.88	0.91	0.82	0.88	0.91	96-104
41-45	0.71	0.82	0.87	0.71	0.82	0.87	105-113
46-50	0.58	0.75	0.82	0.58	0.75	0.82	114-122
51-55	0.41	0.67	0.76	0.41	0.67	0.76	123-131
56-60	—	0.58	0.71	—	0.58	0.71	132-140
61-70	—	0.33	0.58	—	0.33	0.58	141-158
71-80	—	—	0.41	—	—	0.41	159-176

* See 240.4(D).

in raceway or cable with or without an equipment grounding conductor. For application of this section, the main power feeder shall be the feeder(s) between the main disconnect and the lighting and appliance branch-circuit panelboards(s). The feeder conductors to a dwelling unit shall not be required to have an allowable ampacity rating greater than their service-entrance conductors. The grounded conductor shall be permitted to be smaller than the ungrounded conductors, provided the requirements of 215.2, 220.61, and 230.42 are met.

ARTICLE 312
Cabinets, Cutout Boxes,
and Meter Socket Enclosures

312.1 Scope. This article covers the installation and construction specifications of cabinets, cutout boxes, and meter socket enclosures.

I. Installation

312.2 Damp and Wet Locations.

(A) Damp and Wet Locations. In damp or wet locations, surface-type enclosures within the scope of this article shall be placed or equipped so as to prevent moisture or water from entering and accumulating within the cabinet or cutout box, and shall be mounted so there is at least 6-mm ($\frac{1}{4}$ -in.) airspace between the enclosure and the wall or other supporting surface. Enclosures installed in wet locations shall be weatherproof. For enclosures in wet locations, raceways or cables entering above the level of uninsulated live parts shall use fittings listed for wet locations.

Exception: Nonmetallic enclosures shall be permitted to be installed without the airspace on a concrete, masonry, tile, or similar surface.

FPN: For protection against corrosion, see 300.6.

312.3 Position in Wall. In walls of concrete, tile, or other noncombustible material, cabinets shall be installed so that the front edge of the cabinet is not set back of the finished surface more than 6 mm ($\frac{1}{4}$ in.). In walls constructed of wood or other combustible material, cabinets shall be flush with the finished surface or project therefrom.

312.4 Repairing Plaster and Drywall or Plasterboard. Plaster, drywall, or plasterboard surfaces that are broken or incomplete shall be repaired so there will be no gaps or open spaces greater than 3 mm ($\frac{1}{8}$ in.) at the edge of the cabinet or cutout box employing a flush-type cover.

312.5 Cabinets, Cutout Boxes, and Meter Socket Enclosures. Conductors entering enclosures within the scope of this article shall be protected from abrasion and shall comply with 312.5(A) through (C).

(A) Openings to Be Closed. Openings through which conductors enter shall be adequately closed.

(B) Metal Cabinets, Cutout Boxes, and Meter Socket Enclosures. Where metal enclosures within the scope of this article are installed with messenger supported wiring, open wiring on insulators, or concealed knob-and-tube wiring, conductors shall enter through insulating bushings or, in dry locations, through flexible tubing extending from the last insulating support and firmly secured to the enclosure.

(C) Cables. Where cable is used, each cable shall be secured to the cabinet, cutout box, or meter socket enclosure.

Exception: Cables with entirely nonmetallic sheaths shall be permitted to enter the top of a surface-mounted enclosure through one or more nonflexible raceways not less than 450 mm (18 in.) and not more than 3.0 m (10 ft) in length, provided all of the following conditions are met:

(a) Each cable is fastened within 300 mm (12 in.), measured along the sheath, of the outer end of the raceway.

(b) The raceway extends directly above the enclosure and does not penetrate a structural ceiling.

(c) A fitting is provided on each end of the raceway to protect the cable(s) from abrasion and the fittings remain accessible after installation.

(d) The raceway is sealed or plugged at the outer end using approved means so as to prevent access to the enclosure through the raceway.

(e) The cable sheath is continuous through the raceway and extends into the enclosure beyond the fitting not less than 6 mm ($\frac{1}{4}$ in.).

(f) The raceway is fastened at its outer end and at other points in accordance with the applicable article.

(g) Where installed as conduit or tubing, the allowable cable fill does not exceed that permitted for complete conduit or tubing systems by Table 1 of Chapter 9 of this Code and all applicable notes thereto.

FPN: See Table 1 in Chapter 9, including Note 9, for allowable cable fill in circular raceways. See 310.15(B)(2)(a) for required ampacity reductions for multiple cables installed in a common raceway.

312.6 Deflection of Conductors. Conductors at terminals or conductors entering or leaving cabinets or cutout boxes and the like shall comply with 312.6(A) through (C).

(A) Width of Wiring Gutters. Conductors shall not be deflected within a cabinet or cutout box unless a gutter having a width in accordance with Table 312.6(A) is pro-

Table 312.6(A) Minimum Wire-Bending Space at Terminals and Minimum Width of Wiring Gutters

Wire Size (AWG or kcmil)	Wires per Terminal									
	1		2		3		4		5	
	mm	in.	mm	in.	mm	in.	mm	in.	mm	in.
14-10	Not specified		—	—	—	—	—	—	—	—
8-6	38.1	1½	—	—	—	—	—	—	—	—
4-3	50.8	2	—	—	—	—	—	—	—	—
2	63.5	2½	—	—	—	—	—	—	—	—
1	76.2	3	—	—	—	—	—	—	—	—
1/0-2/0	88.9	3½	127	5	178	7	—	—	—	—
3/0-4/0	102	4	152	6	203	8	—	—	—	—
250	114	4½	152	6	203	8	254	10	—	—
300-350	127	5	203	8	254	10	305	12	—	—
400-500	152	6	203	8	254	10	305	12	356	14
600-700	203	8	254	10	305	12	356	14	406	16
750-900	203	8	305	12	356	14	406	16	457	18
1000-1250	254	10	—	—	—	—	—	—	—	—
1500-2000	305	12	—	—	—	—	—	—	—	—

Note: Bending space at terminals shall be measured in a straight line from the end of the lug or wire connector (in the direction that the wire leaves the terminal) to the wall, barrier, or obstruction.

vided. Conductors in parallel in accordance with 310.4 shall be judged on the basis of the number of conductors in parallel.

(B) Wire-Bending Space at Terminals. Wire-bending space at each terminal shall be provided in accordance with 312.6(B)(1) or (B)(2).

(1) Conductors Not Entering or Leaving Opposite Wall. Table 312.6(A) shall apply where the conductor does not enter or leave the enclosure through the wall opposite its terminal.

(2) Conductors Entering or Leaving Opposite Wall. Table 312.6(B) shall apply where the conductor does enter or leave the enclosure through the wall opposite its terminal.

Exception No. 1: Where the distance between the wall and its terminal is in accordance with Table 312.6(A), a conductor shall be permitted to enter or leave an enclosure through the wall opposite its terminal, provided the conductor enters or leaves the enclosure where the gutter joins an adjacent gutter that has a width that conforms to Table 312.6(B) for the conductor.

Exception No. 2: A conductor not larger than 350 kcmil shall be permitted to enter or leave an enclosure containing only a meter socket(s) through the wall opposite its terminal, provided the distance between the terminal and the opposite wall is not less than that specified in Table 312.6(A) and

the terminal is a lay-in type, where the terminal is either of the following:

(a) Directed toward the opening in the enclosure and within a 45 degree angle of directly facing the enclosure wall

(b) Directly facing the enclosure wall and offset not greater than 50 percent of the bending space specified in Table 312.6(A)

FPN: Offset is the distance measured along the enclosure wall from the axis of the centerline of the terminal to a line passing through the center of the opening in the enclosure.

(C) Conductors 4 AWG or Larger. Installation shall comply with 300.4(F).

312.7 Space in Enclosures. Cabinets and cutout boxes shall have sufficient space to accommodate all conductors installed in them without crowding.

312.8 Enclosures for Switches or Overcurrent Devices. Enclosures for switches or overcurrent devices shall not be used as junction boxes, auxiliary gutters, or raceways for conductors feeding through or tapping off to other switches or overcurrent devices, unless adequate space for this purpose is provided. The conductors shall not fill the wiring space at any cross section to more than 40 percent of the cross-sectional area of the space, and the conductors, splices, and taps shall not fill the wiring space at any cross section

Table 312.6(B) Minimum Wire-Bending Space at Terminals

Wire Size (AWG or kcmil)		Wires per Terminal							
		1		2		3		4 or More	
All Other Conductors	Compact Stranded AA-8000 Aluminum Alloy Conductors (See Note 3.)	mm	in.	mm	in.	mm	in.	mm	in.
		14-10	12-8	Not specified		—	—	—	—
8	6	38.1	1½	—	—	—	—	—	—
6	4	50.8	2	—	—	—	—	—	—
4	2	76.2	3	—	—	—	—	—	—
3	1	76.2	3	—	—	—	—	—	—
2	1/0	88.9	3½	—	—	—	—	—	—
1	2/0	114	4½	—	—	—	—	—	—
1/0	3/0	140	5½	140	5½	178	7	—	—
2/0	4/0	152	6	152	6	190	7½	—	—
3/0	250	165 ^a	6½ ^a	165 ^a	6½ ^a	203	8	—	—
4/0	300	178 ^b	7 ^b	190 ^c	7½ ^c	216 ^a	8½ ^a	—	—
250	350	216 ^d	8½ ^d	229 ^d	8½ ^d	254 ^b	9 ^b	254	10
300	400	254 ^e	10 ^e	254 ^d	10 ^d	279 ^b	11 ^b	305	12
350	500	305 ^e	12 ^e	305 ^e	12 ^e	330 ^e	13 ^e	356 ^d	14 ^d
400	600	330 ^e	13 ^e	330 ^e	13 ^e	356 ^e	14 ^e	381 ^e	15 ^e
500	700-750	356 ^e	14 ^e	356 ^e	14 ^e	381 ^e	15 ^e	406 ^e	16 ^e
600	800-900	381 ^e	15 ^e	406 ^e	16 ^e	457 ^e	18 ^e	483 ^e	19 ^e
700	1000	406 ^e	16 ^e	457 ^e	18 ^e	508 ^e	20 ^e	559 ^e	22 ^e
750	—	432 ^e	17 ^e	483 ^e	19 ^e	559 ^e	22 ^e	610 ^e	24 ^e
800	—	457	18	508	20	559	22	610	24
900	—	483	19	559	22	610	24	610	24
1000	—	508	20	—	—	—	—	—	—
1250	—	559	22	—	—	—	—	—	—
1500	—	610	24	—	—	—	—	—	—
1750	—	610	24	—	—	—	—	—	—
2000	—	610	24	—	—	—	—	—	—

- Bending space at terminals shall be measured in a straight line from the end of the lug or wire connector in a direction perpendicular to the enclosure wall.
- For removable and lay-in wire terminals intended for only one wire, bending space shall be permitted to be reduced by the following number of millimeters (inches):
 - ^a 12.7 mm (½ in.)
 - ^b 25.4 mm (1 in.)
 - ^c 38.1 mm (1½ in.)
 - ^d 50.8 mm (2 in.)
 - ^e 76.2 mm (3 in.)
- This column shall be permitted to determine the required wire-bending space for compact stranded aluminum conductors in sizes up to 1000 kcmil and manufactured using AA-8000 series electrical grade aluminum alloy conductor material in accordance with 310.14.

to more than 75 percent of the cross-sectional area of that space.

ARTICLE 314
Outlet, Device, Pull, and Junction Boxes;
Conduit Bodies; Fittings; and Handhole
Enclosures

I. Scope and General

314.1 Scope. This article covers the installation and use of all boxes and conduit bodies used as outlet, device, junction, or pull boxes, depending on their use, and handhole enclosures. Cast, sheet metal, nonmetallic, and other boxes such as FS, FD, and larger boxes are not classified as conduit bodies. This article also includes installation requirements for fittings used to join raceways and to connect raceways and cables to boxes and conduit bodies.

314.2 Round Boxes. Round boxes shall not be used where conduits or connectors requiring the use of locknuts or bushings are to be connected to the side of the box.

314.3 Nonmetallic Boxes. Nonmetallic boxes shall be permitted only with open wiring on insulators, concealed knob-and-tube wiring, cabled wiring methods with entirely nonmetallic sheaths, flexible cords, and nonmetallic raceways.

Exception No. 1: Where internal bonding means are provided between all entries, nonmetallic boxes shall be permitted to be used with metal raceways or metal-armored cables.

Exception No. 2: Where integral bonding means with a provision for attaching an equipment bonding jumper inside the box are provided between all threaded entries in nonmetallic boxes listed for the purpose, nonmetallic boxes shall be permitted to be used with metal raceways or metal-armored cables.

314.4 Metal Boxes. All metal boxes shall be grounded in accordance with the provisions of Article 250.

314.5 Short-Radius Conduit Bodies. Conduit bodies such as capped elbows and service-entrance elbows that enclose conductors 6 AWG or smaller, and are only intended to enable the installation of the raceway and the contained conductors, shall not contain splices, taps, or devices and shall be of sufficient size to provide free space for all conductors enclosed in the conduit body.

II. Installation

314.15 Damp or Wet Locations.

(A) Damp or Wet Locations. In damp or wet locations, boxes, conduit bodies, and fittings shall be placed or equipped so as to prevent moisture from entering or accumulating within the box, conduit body, or fitting. Boxes, conduit bodies, and fittings installed in wet locations shall be listed for use in wet locations.

FPN: No. 1: For boxes in floors, see 314.27(C).

314.16 Number of Conductors in Outlet, Device, and Junction Boxes, and Conduit Bodies. Boxes and conduit bodies shall be of sufficient size to provide free space for all enclosed conductors. In no case shall the volume of the box, as calculated in 314.16(A), be less than the fill calculation as calculated in 314.16(B). The minimum volume for conduit bodies shall be as calculated in 314.16(C).

The provisions of this section shall not apply to terminal housings supplied with motors.

FPN: For volume requirements of motor terminal housings, see 430.12 in the *NEC*.

Boxes and conduit bodies enclosing conductors 4 AWG or larger shall also comply with the provisions of 314.28.

(A) Box Volume Calculations. The volume of a wiring enclosure (box) shall be the total volume of the assembled sections and, where used, the space provided by plaster rings, domed covers, extension rings, and so forth, that are marked with their volume or are made from boxes the dimensions of which are listed in Table 314.16(A).

(1) Standard Boxes. The volumes of standard boxes that are not marked with their volume shall be as given in Table 314.16(A).

(2) Other Boxes. Boxes 1650 cm³ (100 in.³) or less, other than those described in Table 314.16(A), and nonmetallic boxes shall be durably and legibly marked by the manufacturer with their volume. Boxes described in Table 314.16(A) that have a volume larger than is designated in the table shall be permitted to have their volume marked as required by this section.

(B) Box Fill Calculations. The volumes in paragraphs 314.16(B)(1) through (B)(5), as applicable, shall be added together. No allowance shall be required for small fittings such as locknuts and bushings.

(1) Conductor Fill. Each conductor that originates outside the box and terminates or is spliced within the box shall be counted once, and each conductor that passes through the box without splice or termination shall be counted once. A looped, unbroken conductor not less than twice the minimum

Table 314.16(A) Metal Boxes

Box Trade Size			Minimum Volume		Maximum Number of Conductors*						
			mm	in.	cm ³	in. ³	18	16	14	12	10
100 × 32	(4 × 1¼)	round/octagonal	205	12.5	8	7	6	5	5	5	2
100 × 38	(4 × 1½)	round/octagonal	254	15.5	10	8	7	6	6	5	3
100 × 54	(4 × 2⅛)	round/octagonal	353	21.5	14	12	10	9	8	7	4
100 × 32	(4 × 1¼)	square	295	18.0	12	10	9	8	7	6	3
100 × 38	(4 × 1½)	square	344	21.0	14	12	10	9	8	7	4
100 × 54	(4 × 2⅛)	square	497	30.3	20	17	15	13	12	10	6
120 × 32	(4⅞/16 × 1¼)	square	418	25.5	17	14	12	11	10	8	5
120 × 38	(4⅞/16 × 1½)	square	484	29.5	19	16	14	13	11	9	5
120 × 54	(4⅞/16 × 2⅛)	square	689	42.0	28	24	21	18	16	14	8
75 × 50 × 38	(3 × 2 × 1½)	device	123	7.5	5	4	3	3	3	2	1
75 × 50 × 50	(3 × 2 × 2)	device	164	10.0	6	5	5	4	4	3	2
75 × 50 × 57	(3 × 2 × 2¼)	device	172	10.5	7	6	5	4	4	3	2
75 × 50 × 65	(3 × 2 × 2½)	device	205	12.5	8	7	6	5	5	4	2
75 × 50 × 70	(3 × 2 × 2¾)	device	230	14.0	9	8	7	6	5	4	2
75 × 50 × 90	(3 × 2 × 3½)	device	295	18.0	12	10	9	8	7	6	3
100 × 54 × 38	(4 × 2⅛ × 1½)	device	169	10.3	6	5	5	4	4	3	2
100 × 54 × 48	(4 × 2⅛ × 1⅞)	device	213	13.0	8	7	6	5	5	4	2
100 × 54 × 54	(4 × 2⅛ × 2⅛)	device	238	14.5	9	8	7	6	5	4	2
95 × 50 × 65	(3¾ × 2 × 2½)	masonry box/gang	230	14.0	9	8	7	6	5	4	2
95 × 50 × 90	(3¾ × 2 × 3½)	masonry box/gang	344	21.0	14	12	10	9	8	7	4
min. 44.5 depth	FS — single cover/gang (1¾)		221	13.5	9	7	6	6	5	4	2
min. 60.3 depth	FD — single cover/gang (2⅞)		295	18.0	12	10	9	8	7	6	3
min. 44.5 depth	FS — multiple cover/gang (1¾)		295	18.0	12	10	9	8	7	6	3
min. 60.3 depth	FD — multiple cover/gang (2⅞)		395	24.0	16	13	12	10	9	8	4

*Where no volume allowances are required by 314.16(B)(2) through (B)(5).

length required for free conductors in 300.14 shall be counted twice. The conductor fill shall be calculated using Table 314.16(B). A conductor, no part of which leaves the box, shall not be counted.

Exception: An equipment grounding conductor or conductors or not over four fixture wires smaller than 14 AWG, or both, shall be permitted to be omitted from the calculations where they enter a box from a domed luminaire (fixture) or similar canopy and terminate within that box.

(2) Clamp Fill. Where one or more internal cable clamps, whether factory or field supplied, are present in the box, a single volume allowance in accordance with Table 314.16(B) shall be made based on the largest conductor present in the box. No allowance shall be required for a cable connector with its clamping mechanism outside the box.

(3) Support Fittings Fill. Where one or more luminaire (fixture) studs or hickies are present in the box, a single

volume allowance in accordance with Table 314.16(B) shall be made for each type of fitting based on the largest conductor present in the box.

(4) Device or Equipment Fill. For each yoke or strap containing one or more devices or equipment, a double volume allowance in accordance with Table 314.16(B) shall be made for each yoke or strap based on the largest conductor connected to a device(s) or equipment supported by that yoke or strap.

(5) Equipment Grounding Conductor Fill. Where one or more equipment grounding conductors or equipment bonding jumpers enter a box, a single volume allowance in accordance with Table 314.16(B) shall be made based on the largest equipment grounding conductor or equipment bonding jumper present in the box. Where an additional set of equipment grounding conductors, as permitted by 250.146(D) in the NEC, is present in the box, an additional

Table 314.16(B) Volume Allowance Required per Conductor

Size of Conductor (AWG)	Free Space Within Box for Each Conductor	
	cm ³	in. ³
18	24.6	1.50
16	28.7	1.75
14	32.8	2.00
12	36.9	2.25
10	41.0	2.50
8	49.2	3.00
6	81.9	5.00

volume allowance shall be made based on the largest equipment grounding conductor in the additional set.

(C) Conduit Bodies.

(1) General. Conduit bodies enclosing 6 AWG conductors or smaller, other than short-radius conduit bodies as described in 314.5, shall have a cross-sectional area not less than twice the cross-sectional area of the largest conduit or tubing to which it is attached. The maximum number of conductors permitted shall be the maximum number permitted by Table 1 of Chapter 9 for the conduit or tubing to which it is attached.

(2) With Splices, Taps, or Devices. Only those conduit bodies that are durably and legibly marked by the manufacturer with their volume shall be permitted to contain splices, taps, or devices. The maximum number of conductors shall be calculated in accordance with 314.16(B). Conduit bodies shall be supported in a rigid and secure manner.

314.17 Conductors Entering Boxes, Conduit Bodies, or Fittings. Conductors entering boxes, conduit bodies, or fittings shall be protected from abrasion and shall comply with 314.17(A) through (D).

(A) Openings to Be Closed. Openings through which conductors enter shall be adequately closed.

(B) Metal Boxes and Conduit Bodies. Where metal boxes or conduit bodies are installed with messenger supported wiring, open wiring on insulators, or concealed knob-and-tube wiring, conductors shall enter through insulating bushings or, in dry locations, through flexible tubing extending from the last insulating support to not less than 6 mm (¼ in.) inside the box and beyond any cable clamps. Except as provided in 300.15(C), the wiring shall be firmly secured to the box or conduit body. Where raceway or cable is installed with metal boxes or conduit bodies, the raceway or cable shall be secured to such boxes and conduit bodies.

(C) Nonmetallic Boxes and Conduit Bodies. Nonmetallic boxes and conduit bodies shall be suitable for the lowest temperature-rated conductor entering the box. Where nonmetallic boxes and conduit bodies are used with messenger supported wiring, open wiring on insulators, or concealed knob-and-tube wiring, the conductors shall enter the box through individual holes. Where flexible tubing is used to enclose the conductors, the tubing shall extend from the last insulating support to not less than 6 mm (¼ in.) inside the box and beyond any cable clamp. Where nonmetallic-sheathed cable or multiconductor Type UF cable is used, the sheath shall extend not less than 6 mm (¼ in.) inside the box and beyond any cable clamp. In all instances, all permitted wiring methods shall be secured to the boxes.

Exception: Where nonmetallic-sheathed cable or multiconductor Type UF cable is used with single gang boxes not larger than a nominal size 57 mm × 100 mm (2¼ in. × 4 in.) mounted in walls or ceilings, and where the cable is fastened within 200 mm (8 in.) of the box measured along the sheath and where the sheath extends through a cable knockout not less than 6 mm (¼ in.), securing the cable to the box shall not be required. Multiple cable entries shall be permitted in a single cable knockout opening.

(D) Conductors 4 AWG or Larger. Installation shall comply with 300.4(F).

FPN: See 110.12(A) for requirements on closing unused cable and raceway knockout openings.

314.19 Boxes Enclosing Flush Devices. Boxes used to enclose flush devices shall be of such design that the devices will be completely enclosed on back and sides and substantial support for the devices will be provided. Screws for supporting the box shall not be used in attachment of the device contained therein.

314.20 In Wall or Ceiling. In walls or ceilings with a surface of concrete, tile, gypsum, plaster, or other noncombustible material, boxes employing a flush-type cover or faceplate shall be installed so that the front edge of the box, plaster ring, extension ring, or listed extender will not be set back of the finished surface more than 6 mm (¼ in.).

In walls and ceilings constructed of wood or other combustible surface material, boxes, plaster rings, extension rings, or listed extenders shall be flush with the finished surface or project therefrom.

314.21 Repairing Plaster and Drywall or Plasterboard. Plaster, drywall, or plasterboard surfaces that are broken or incomplete around boxes employing a flush-type cover or faceplate shall be repaired so there will be no gaps or open spaces greater than 3 mm (⅛ in.) at the edge of the box.

314.22 Exposed Surface Extensions. Surface extensions from a flush-mounted box shall be made by mounting and mechanically securing an extension ring over the flush box. Equipment grounding and bonding shall be in accordance with Article 250.

Exception: A surface extension shall be permitted to be made from the cover of a flush-mounted box where the cover is designed so it is unlikely to fall off or be removed if its securing means becomes loose. The wiring method shall be flexible for a length sufficient to permit removal of the cover and provide access to the box interior, and arranged so that any bonding or grounding continuity is independent of the connection between the box and cover.

314.23 Supports. Enclosures within the scope of this article shall be supported in accordance with one or more of the provisions in 314.23(A) through (H).

(A) Surface Mounting. An enclosure mounted on a building or other surface shall be rigidly and securely fastened in place. If the surface does not provide rigid and secure support, additional support in accordance with other provisions of this section shall be provided.

(B) Structural Mounting. An enclosure supported from a structural member of a building or from grade shall be rigidly supported either directly or by using a metal, polymeric, or wood brace.

(1) Nails and Screws. Nails and screws, where used as a fastening means, shall be attached by using brackets on the outside of the enclosure, or they shall pass through the interior within 6 mm (¼ in.) of the back or ends of the enclosure. Screws shall not be permitted to pass through the box unless exposed threads in the box are protected using approved means to avoid abrasion of conductor insulation.

(2) Braces. Metal braces shall be protected against corrosion and formed from metal that is not less than 0.51 mm (0.020 in.) thick uncoated. Wood braces shall have a cross section not less than nominal 25 mm × 50 mm (1 in. × 2 in.). Wood braces in wet locations shall be treated for the conditions. Polymeric braces shall be identified as being suitable for the use.

(C) Mounting in Finished Surfaces. An enclosure mounted in a finished surface shall be rigidly secured thereto by clamps, anchors, or fittings identified for the application.

(D) Suspended Ceilings. An enclosure mounted to structural or supporting elements of a suspended ceiling shall be not more than 1650 cm³ (100 in.³) in size and shall be securely fastened in place in accordance with either (D)(1) or (D)(2).

(1) Framing Members. An enclosure shall be fastened to the framing members by mechanical means such as bolts, screws, or rivets, or by the use of clips or other securing means identified for use with the type of ceiling framing member(s) and enclosure(s) employed. The framing members shall be adequately supported and securely fastened to each other and to the building structure.

(2) Support Wires. The installation shall comply with the provisions of 300.11(A). The enclosure shall be secured, using methods identified for the purpose, to ceiling support wire(s), including any additional support wire(s) installed for that purpose. Support wire(s) used for enclosure support shall be fastened at each end so as to be taut within the ceiling cavity.

(E) Raceway Supported Enclosure, Without Devices, Luminaires (Fixtures), or Lampholders. An enclosure that does not contain a device(s) other than splicing devices or support a luminaire(s) [fixture(s)], lampholder, or other equipment and is supported by entering raceways shall not exceed 1650 cm³ (100 in.³) in size. It shall have threaded entries or have hubs identified for the purpose. It shall be supported by two or more conduits threaded wrenchtight into the enclosure or hubs. Each conduit shall be secured within 900 mm (3 ft) of the enclosure, or within 450 mm (18 in.) of the enclosure if all conduit entries are on the same side.

Exception: Rigid metal, intermediate metal, or rigid nonmetallic conduit or electrical metallic tubing shall be permitted to support a conduit body of any size, including a conduit body constructed with only one conduit entry, provided the trade size of the conduit body is not larger than the largest trade size of the conduit or electrical metallic tubing.

(F) Raceway Supported Enclosures, with Devices, Luminaires (Fixtures), or Lampholders. An enclosure that contains a device(s), other than splicing devices, or supports a luminaire(s) [fixture(s)], lampholder, or other equipment and is supported by entering raceways shall not exceed 1650 cm³ (100 in.³) in size. It shall have threaded entries or have hubs identified for the purpose. It shall be supported by two or more conduits threaded wrenchtight into the enclosure or hubs. Each conduit shall be secured within 450 mm (18 in.) of the enclosure.

Exception No. 1: Rigid metal or intermediate metal conduit shall be permitted to support a conduit body of any size, including a conduit body constructed with only one conduit entry, provided the trade size of the conduit body is not larger than the largest trade size of the conduit.

Exception No. 2: An unbroken length(s) of rigid or intermediate metal conduit shall be permitted to support a box used for luminaire (fixture) or lampholder support, or to support

a wiring enclosure that is an integral part of a luminaire (fixture) and used in lieu of a box in accordance with 300.15(B), where all of the following conditions are met:

(a) The conduit is securely fastened at a point so that the length of conduit beyond the last point of conduit support does not exceed 900 mm (3 ft).

(b) The unbroken conduit length before the last point of conduit support is 300 mm (12 in.) or greater, and that portion of the conduit is securely fastened at some point not less than 300 mm (12 in.) from its last point of support.

(c) Where accessible to unqualified persons, the luminaire (fixture) or lampholder, measured to its lowest point, is at least 2.5 m (8 ft) above grade or standing area and at least 900 mm (3 ft) measured horizontally to the 2.5 m (8 ft) elevation from windows, doors, porches, fire escapes, or similar locations.

(d) A luminaire (fixture) supported by a single conduit does not exceed 300 mm (12 in.) in any direction from the point of conduit entry.

(e) The weight supported by any single conduit does not exceed 9 kg (20 lb).

(f) At the luminaire (fixture) or lampholder end, the conduit(s) is threaded wrenchtight into the box, conduit body, or integral wiring enclosure, or into hubs identified for the purpose. Where a box or conduit body is used for support, the luminaire (fixture) shall be secured directly to the box or conduit body, or through a threaded conduit nipple not over 75 mm (3 in.) long.

(G) Enclosures in Concrete or Masonry. An enclosure supported by embedment shall be identified as suitably protected from corrosion and securely embedded in concrete or masonry.

(H) Pendant Boxes. An enclosure supported by a pendant shall comply with 314.23(H)(1) or (H)(2).

(1) Flexible Cord. A box shall be supported from a multi-conductor cord or cable in an approved manner that protects the conductors against strain, such as a strain-relief connector threaded into a box with a hub.

(2) Conduit. A box supporting lampholders or luminaires (lighting fixtures), or wiring enclosures within luminaires (fixtures) used in lieu of boxes in accordance with 300.15(B), shall be supported by rigid or intermediate metal conduit stems. For stems longer than 450 mm (18 in.), the stems shall be connected to the wiring system with flexible fittings suitable for the location. At the luminaire (fixture) end, the conduit(s) shall be threaded wrenchtight into the box or wiring enclosure, or into hubs identified for the purpose.

Where supported by only a single conduit, the threaded joints shall be prevented from loosening by the use of set-screws or other effective means, or the luminaire (fixture), at any point, shall be at least 2.5 m (8 ft) above grade or

standing area and at least 900 mm (3 ft) measured horizontally to the 2.5 m (8 ft) elevation from windows, doors, porches, fire escapes, or similar locations. A luminaire (fixture) supported by a single conduit shall not exceed 300 mm (12 in.) in any horizontal direction from the point of conduit entry.

314.24 Depth of Outlet Boxes. No box shall have an internal depth of less than 12.7 mm (½ in.). Boxes intended to enclose flush devices shall have an internal depth of not less than 23.8 mm (1⁵/₁₆ in.).

314.25 Covers and Canopies. In completed installations, each box shall have a cover, faceplate, lampholder, or luminaire (fixture) canopy, except where the installation complies with 410.14(B).

(A) Nonmetallic or Metal Covers and Plates. Nonmetallic or metal covers and plates shall be permitted. Where metal covers or plates are used, they shall comply with the grounding requirements of 250.110.

FPN: For additional grounding requirements, see 410.18(A) for metal luminaire (fixture) canopies, and 404.12 and 406.5(B) for metal faceplates.

(B) Exposed Combustible Wall or Ceiling Finish. Where a luminaire (fixture) canopy or pan is used, any combustible wall or ceiling finish exposed between the edge of the canopy or pan and the outlet box shall be covered with noncombustible material.

(C) Flexible Cord Pendants. Covers of outlet boxes and conduit bodies having holes through which flexible cord pendants pass shall be provided with bushings designed for the purpose or shall have smooth, well-rounded surfaces on which the cords may bear. So-called hard rubber or composition bushings shall not be used.

314.27 Outlet Boxes.

(A) Boxes at Luminaire (Lighting Fixture) Outlets. Boxes used at luminaire (lighting fixture) or lampholder outlets shall be designed for the purpose. At every outlet used exclusively for lighting, the box shall be designed or installed so that a luminaire (lighting fixture) may be attached.

Exception: A wall-mounted luminaire (fixture) weighing not more than 3 kg (6 lb) shall be permitted to be supported on other boxes or plaster rings that are secured to other boxes, provided the luminaire (fixture) or its supporting yoke is secured to the box with no fewer than two No. 6 or larger screws.

(B) Maximum Luminaire (Fixture) Weight. Outlet boxes or fittings installed as required by 314.23 shall be permitted

to support luminaires (lighting fixtures) weighing 23 kg (50 lb) or less. A luminaire (lighting fixture) that weighs more than 23 kg (50 lb) shall be supported independently of the outlet box unless the outlet box is listed for the weight to be supported.

(C) Floor Boxes. Boxes listed specifically for this application shall be used for receptacles located in the floor.

Exception: Where the authority having jurisdiction judges them free from likely exposure to physical damage, moisture, and dirt, boxes located in elevated floors of show windows and similar locations shall be permitted to be other than those listed for floor applications. Receptacles and covers shall be listed as an assembly for this type of location.

(D) Boxes at Ceiling-Suspended (Paddle) Fan Outlets. Outlet boxes or outlet box systems used as the sole support of a ceiling-suspended (paddle) fan shall be listed, shall be marked by their manufacturer as suitable for this purpose, and shall not support ceiling-suspended (paddle) fans that weigh more than 32 kg (70 lb). For outlet boxes or outlet box systems designed to support ceiling-suspended (paddle) fans that weigh more than 16 kg (35 lb), the required marking shall include the maximum weight to be supported.

314.28 Pull and Junction Boxes and Conduit Bodies. Boxes and conduit bodies used as pull or junction boxes shall comply with 314.28(A) through (D).

Exception: Terminal housings supplied with motors shall comply with the provisions of 430.12 in the NEC.

(A) Minimum Size. For raceways containing conductors of 4 AWG or larger, and for cables containing conductors of 4 AWG or larger, the minimum dimensions of pull or junction boxes installed in a raceway or cable run shall comply with (A)(1) through (A)(3). Where an enclosure dimension is to be calculated based on the diameter of entering raceways, the diameter shall be the metric designator (trade size) expressed in the units of measurement employed.

(1) Straight Pulls. In straight pulls, the length of the box shall not be less than eight times the metric designator (trade size) of the largest raceway.

(2) Angle or U Pulls. Where splices or where angle or U pulls are made, the distance between each raceway entry inside the box and the opposite wall of the box shall not be less than six times the metric designator (trade size) of the largest raceway in a row. This distance shall be increased for additional entries by the amount of the sum of the diameters of all other raceway entries in the same row on the same wall of the box. Each row shall be calculated individually, and the single row that provides the maximum distance shall be used.

Exception: Where a raceway or cable entry is in the wall of a box or conduit body opposite a removable cover, the distance from that wall to the cover shall be permitted to comply with the distance required for one wire per terminal in Table 312.6(A).

The distance between raceway entries enclosing the same conductor shall not be less than six times the metric designator (trade size) of the larger raceway.

When transposing cable size into raceway size in 314.28(A)(1) and (A)(2), the minimum metric designator (trade size) raceway required for the number and size of conductors in the cable shall be used.

(3) Smaller Dimensions. Boxes or conduit bodies of dimensions less than those required in 314.28(A)(1) and (A)(2) shall be permitted for installations of combinations of conductors that are less than the maximum conduit or tubing fill (of conduits or tubing being used) permitted by Table 1 of Chapter 9, provided the box or conduit body has been listed for, and is permanently marked with, the maximum number and maximum size of conductors permitted.

(B) Conductors in Pull or Junction Boxes. In pull boxes or junction boxes having any dimension over 1.8 m (6 ft), all conductors shall be cabled or racked up in an approved manner.

(C) Covers. All pull boxes, junction boxes, and conduit bodies shall be provided with covers compatible with the box or conduit body construction and suitable for the conditions of use. Where used, metal covers shall comply with the grounding requirements of 250.110. An extension from the cover of an exposed box shall comply with 314.22, Exception.

(D) Permanent Barriers. Where permanent barriers are installed in a box, each section shall be considered as a separate box.

314.29 Boxes, Conduit Bodies, and Handhole Enclosures to Be Accessible. Boxes, conduit bodies, and handhole enclosures shall be installed so that the wiring contained in them can be rendered accessible without removing any part of the building or, in underground circuits, without excavating sidewalks, paving, earth, or other substance that is to be used to establish the finished grade.

Exception: Listed boxes and handhole enclosures shall be permitted where covered by gravel, light aggregate, or non-cohesive granulated soil if their location is effectively identified and accessible for excavation.

314.30 Handhole Enclosures. Handhole enclosures shall be designed and installed to withstand all loads likely to be imposed.

FPN: See ANSI/SCTE 77-2002, *Specification for Underground Enclosure Integrity*, for additional information on deliberate and nondeliberate traffic loading that can be expected to bear on underground enclosures.

(A) Size. Handhole enclosures shall be sized in accordance with 314.28(A) for conductors operating at 600 volts or below, and in accordance with 314.71 in the *NEC* for conductors operating at over 600 volts. For handhole enclosures without bottoms where the provisions of 314.28(A)(2), Exception, or of 314.71(B)(1), Exception No. 1 in the *NEC*, apply, the measurement to the removable cover shall be taken from the end of the conduit or cable assembly.

(B) Wiring Entries. Underground raceways and cable assemblies entering a handhole enclosure shall extend into the enclosure, but they shall not be required to be mechanically connected to the enclosure.

(C) Handhole Enclosures Without Bottoms. Where handhole enclosures without bottoms are installed, all enclosed conductors and any splices or terminations, if present, shall be listed as suitable for wet locations.

(D) Covers. Handhole enclosure covers shall have an identifying mark or logo that prominently identifies the function of the enclosure, such as “electric.” Handhole enclosure covers shall require the use of tools to open, or they shall weigh over 45 kg (100 lb). Metal covers and other exposed conductive surfaces shall be bonded in accordance with 250.96(A).

ARTICLE 320 Armored Cable: Type AC

I. General

320.1 Scope. This article covers the use, installation, and construction specifications for armored cable, Type AC.

320.2 Definition.

Armored Cable, Type AC. A fabricated assembly of insulated conductors in a flexible metallic enclosure. See 320.100 in the *NEC*.

II. Installation

320.10 Uses Permitted. Type AC cable shall be permitted as follows:

- (1) In both exposed and concealed work
- (2) In cable trays
- (3) In dry locations

- (4) Embedded in plaster finish on brick or other masonry, except in damp or wet locations
- (5) To be run or fished in the air voids of masonry block or tile walls where such walls are not exposed or subject to excessive moisture or dampness

FPN: The “Uses Permitted” is not an all-inclusive list.

320.12 Uses Not Permitted. Type AC cable shall not be used as follows:

- (1) Where subject to physical damage
- (2) In damp or wet locations
- (3) In air voids of masonry block or tile walls where such walls are exposed or subject to excessive moisture or dampness
- (4) Where exposed to corrosive fumes or vapors
- (5) Embedded in plaster finish on brick or other masonry in damp or wet locations

320.15 Exposed Work. Exposed runs of cable, except as provided in 300.11(A), shall closely follow the surface of the building finish or of running boards. Exposed runs shall also be permitted to be installed on the underside of joists where supported at each joist and located so as not to be subject to physical damage.

320.17 Through or Parallel to Framing Members. Type AC cable shall be protected in accordance with 300.4(A), (C), and (D) where installed through or parallel to framing members.

320.23 In Accessible Attics. Type AC cables in accessible attics or roof spaces shall be installed as specified in 320.23(A) and (B).

(A) Where Run Across the Top of Floor Joists. Where run across the top of floor joists, or within 2.1 m (7 ft) of floor or floor joists across the face of rafters or studding, in attics and roof spaces that are accessible, the cable shall be protected by substantial guard strips that are at least as high as the cable. Where this space is not accessible by permanent stairs or ladders, protection shall only be required within 1.8 m (6 ft) of the nearest edge of the scuttle hole or attic entrance.

(B) Cable Installed Parallel to Framing Members. Where the cable is installed parallel to the sides of rafters, studs, or floor joists, neither guard strips nor running boards shall be required, and the installation shall also comply with 300.4(D).

320.24 Bending Radius. Bends in Type AC cable shall be made such that the cable is not damaged. The radius of the

curve of the inner edge of any bend shall not be less than five times the diameter of the Type AC cable.

320.30 Securing and Supporting.

(A) General. Type AC cable shall be supported and secured by staples, cable ties, straps, hangers, or similar fittings, designed and installed so as not to damage the cable.

(B) Securing. Unless otherwise provided, Type AC cable shall be secured within 300 mm (12 in.) of every outlet box, junction box, cabinet, or fitting and at intervals not exceeding 1.4 m (4½ ft) where installed on or across framing members.

(C) Supporting. Unless otherwise provided, Type AC cable shall be supported at intervals not exceeding 1.4 m (4½ ft).

Horizontal runs of Type AC cable installed in wooden or metal framing members or similar supporting means shall be considered supported where such support does not exceed 1.4 m (4½ ft) intervals.

(D) Unsupported Cables. Type AC cable shall be permitted to be unsupported where the cable complies with any of the following:

- (1) Is fished between access points through concealed spaces in finished buildings or structures and supporting is impracticable
- (2) Is not more than 600 mm (2 ft) in length at terminals where flexibility is necessary
- (3) Is not more than 1.8 m (6 ft) in length from the last point of cable support to the point of connection to a luminaire(s) [lighting fixture(s)] or other electrical equipment and the cable and point of connection are within an accessible ceiling. For the purposes of this section, Type AC cable fittings shall be permitted as a means of cable support.

320.40 Boxes and Fittings. At all points where the armor of AC cable terminates, a fitting shall be provided to protect wires from abrasion, unless the design of the outlet boxes or fittings is such as to afford equivalent protection, and, in addition, an insulating bushing or its equivalent protection shall be provided between the conductors and the armor. The connector or clamp by which the Type AC cable is fastened to boxes or cabinets shall be of such design that the insulating bushing or its equivalent will be visible for inspection. Where change is made from Type AC cable to other cable or raceway wiring methods, a box, fitting, or conduit body shall be installed at junction points as required in 300.15.

320.80 Ampacity. The ampacity shall be determined by 310.15.

(A) Thermal Insulation. Armored cable installed in thermal insulation shall have conductors rated at 90°C (194°F). The ampacity of cable installed in these applications shall be that of 60°C (140°F) conductors. The 90°C (194°F) rating shall be permitted to be used for ampacity derating purposes, provided the final derated ampacity does not exceed that for a 60°C (140°F) rated conductor.

ARTICLE 330 Metal-Clad Cable: Type MC

I. General

330.1 Scope. This article covers the use, installation, and construction specifications of metal-clad cable, Type MC.

330.2 Definition.

Metal Clad Cable, Type MC. A factory assembly of one or more insulated circuit conductors with or without optical fiber members enclosed in an armor of interlocking metal tape, or a smooth or corrugated metallic sheath.

II. Installation

330.10 Uses Permitted.

(A) General Uses. Type MC cable shall be permitted as follows:

- (1) For services, feeders, and branch circuits
- (2) For power, lighting, control, and signal circuits
- (3) Indoors or outdoors
- (4) Exposed or concealed
- (5) To be direct buried where identified for such use
- (7) In any raceway
- (10) In dry locations and embedded in plaster finish on brick or other masonry except in damp or wet locations
- (11) In wet locations where any of the following conditions are met:
 - a. The metallic covering is impervious to moisture.
 - b. A lead sheath or moisture-impervious jacket is provided under the metal covering.
 - c. The insulated conductors under the metallic covering are listed for use in wet locations.

(B) Specific Uses. Type MC cable shall be permitted to be installed in compliance with Parts II and III of Article 725 and 770.133 in the *NEC* as applicable and in accordance with 330.10(B)(2) and (B)(3).

(2) Direct Buried. Direct-buried cable shall comply with 300.5.

(3) Installed as Service-Entrance Cable. Type MC cable installed as service-entrance cable shall be permitted in accordance with 230.43.

FPN: The “Uses Permitted” is not an all-inclusive list.

330.12 Uses Not Permitted. Type MC cable shall not be used where exposed to the following destructive corrosive conditions, unless the metallic sheath is suitable for the conditions or is protected by material suitable for the conditions:

- (1) Where subject to physical damage
- (2) Direct burial in the earth
- (3) In concrete

FPN to (3): MC cable that is identified for direct burial applications is suitable for installation in concrete.

330.17 Through or Parallel to Framing Members. Type MC cable shall be protected in accordance with 300.4(A), (C), and (D) where installed through or parallel to framing members.

330.23 In Accessible Attics. The installation of Type MC cable in accessible attics or roof spaces shall also comply with 320.23.

330.24 Bending Radius. Bends in Type MC cable shall be so made that the cable will not be damaged. The radius of the curve of the inner edge of any bend shall not be less than required in 330.24(A) and (B).

(A) Smooth Sheath.

- (1) Ten times the external diameter of the metallic sheath for cable not more than 19 mm ($\frac{3}{4}$ in.) in external diameter
- (2) Twelve times the external diameter of the metallic sheath for cable more than 19 mm ($\frac{3}{4}$ in.) but not more than 38 mm ($1\frac{1}{2}$ in.) in external diameter
- (3) Fifteen times the external diameter of the metallic sheath for cable more than 38 mm ($1\frac{1}{2}$ in.) in external diameter

(B) Interlocked-Type Armor or Corrugated Sheath. Seven times the external diameter of the metallic sheath.

330.30 Securing and Supporting.

(A) General. Type MC cable shall be supported and secured by staples, cable ties, straps, hangers, or similar fittings or other approved means designed and installed so as not to damage the cable.

(B) Securing. Unless otherwise provided, cables shall be secured at intervals not exceeding 1.8 m (6 ft). Cables containing four or fewer conductors sized no larger than 10 AWG shall be secured within 300 mm (12 in.) of every box, cabinet, fitting, or other cable termination.

(C) Supporting. Unless otherwise provided, cables shall be supported at intervals not exceeding 1.8 m (6 ft).

Horizontal runs of Type MC cable installed in wooden or metal framing members or similar supporting means shall be considered supported and secured where such support does not exceed 1.8 m (6 ft) intervals.

(D) Unsupported Cables. Type MC cable shall be permitted to be unsupported where the cable:

- (1) Is fished between access points through concealed spaces in finished buildings or structures and supporting is impractical; or
- (2) Is not more than 1.8 m (6 ft) in length from the last point of cable support to the point of connection to a luminaire (lighting fixture) or other piece of electrical equipment and the cable and point of connection are within an accessible ceiling. For the purpose of this section, Type MC cable fittings shall be permitted as a means of cable support.

330.40 Boxes and Fitting. Fittings used for connecting Type MC cable to boxes, cabinets, or other equipment shall be listed and identified for such use.

330.80 Ampacity. The ampacity of Type MC cable shall be determined in accordance with 310.15 for 14 AWG and larger conductors. The installation shall not exceed the temperature ratings of terminations and equipment.

ARTICLE 334
Nonmetallic-Sheathed Cable:
Types NM and NMC

I. General

334.1 Scope. This article covers the use, installation, and construction specifications of nonmetallic-sheathed cable.

334.2 Definitions.

Nonmetallic-Sheathed Cable. A factory assembly of two or more insulated conductors enclosed within an overall nonmetallic jacket.

Type NM. Insulated conductors enclosed within an overall nonmetallic jacket.

Type NMC. Insulated conductors enclosed within an overall, corrosion resistant, nonmetallic jacket.

334.6 Listed. Type NM and Type NMC cables shall be listed.

II. Installation

334.10 Uses Permitted. Type NM, and Type NMC, cables shall be permitted to be used in the following:

- (1) One- and two-family dwellings.

FPN: See 310.10 for temperature limitation of conductors.

(A) Type NM. Type NM cable shall be permitted as follows:

- (1) For both exposed and concealed work in normally dry locations except as prohibited in 334.10(3) in the *NEC*
- (2) To be installed or fished in air voids in masonry block or tile walls

(B) Type NMC. Type NMC cable shall be permitted as follows:

- (1) For both exposed and concealed work in dry, moist, damp, or corrosive locations, except as prohibited by 334.10(3) in the *NEC*
- (2) In outside and inside walls of masonry block or tile
- (3) In a shallow chase in masonry, concrete, or adobe protected against nails or screws by a steel plate at least 1.59 mm ($\frac{1}{16}$ in.) thick and covered with plaster, adobe, or similar finish

334.12 Uses Not Permitted.

(A) Types NM and NMC. Types NM and NMC cables shall not be permitted as follows:

- (3) As service-entrance cable
- (9) Embedded in poured cement, concrete, or aggregate

(B) Type NM. Type NM cable shall not be used under the following conditions or in the following locations:

- (2) Where embedded in masonry, concrete, adobe, fill, or plaster
- (3) In a shallow chase in masonry, concrete, or adobe and covered with plaster, adobe, or similar finish
- (4) Where exposed or subject to excessive moisture or dampness

334.15 Exposed Work. In exposed work, except as provided in 300.11(A), cable shall be installed as specified in 334.15(A) through (C).

(A) To Follow Surface. Cable shall closely follow the surface of the building finish or of running boards.

(B) Protection from Physical Damage. Cable shall be protected from physical damage where necessary by rigid metal conduit, intermediate metal conduit, electrical metallic tubing, Schedule 80 PVC rigid nonmetallic conduit, or other approved means. Where passing through a floor, the cable shall be enclosed in rigid metal conduit, intermediate metal conduit, electrical metallic tubing, Schedule 80 PVC rigid nonmetallic conduit, or other approved means extending at least 150 mm (6 in.) above the floor.

Where Type NMC cable is installed in shallow chases in masonry, concrete, or adobe, the cable shall be protected against nails or screws by a steel plate at least 1.59 mm ($\frac{1}{16}$ in.) thick and covered with plaster, adobe, or similar finish.

(C) In Unfinished Basements. Where cable is run at angles with joists in unfinished basements, it shall be permissible to secure cables not smaller than two 6 AWG or three 8 AWG conductors directly to the lower edges of the joists. Smaller cables shall be run either through bored holes in joists or on running boards. NM cable used on a wall of an unfinished basement shall be permitted to be installed in a listed conduit or tubing. Conduit or tubing shall utilize a nonmetallic bushing or adapter at the point the cable enters the raceway. Metal conduit and tubings and metal outlet boxes shall be grounded.

334.17 Through or Parallel to Framing Members. Types NM, NMC, or NMS cable shall be protected in accordance with 300.4 where installed through or parallel to framing members. Grommets used as required in 300.4(B)(1) shall remain in place and be listed for the purpose of cable protection.

334.23 In Accessible Attics. The installation of cable in accessible attics or roof spaces shall also comply with 320.23.

334.24 Bending Radius. Bends in Types NM and NMC cable shall be so made that the cable will not be damaged. The radius of the curve of the inner edge of any bend during or after installation shall not be less than five times the diameter of the cable.

334.30 Securing and Supporting. Nonmetallic-sheathed cable shall be supported and secured by staples, cable ties, straps, hangers, or similar fittings designed and installed so as not to damage the cable, at intervals not exceeding 1.4 m (4½ ft) and within 300 mm (12 in.) of every outlet box, junction box, cabinet, or fitting. Flat cables shall not be stapled on edge.

Sections of cable protected from physical damage by raceway shall not be required to be secured within the raceway.

(A) Horizontal Runs Through Holes and Notches. In other than vertical runs, cables installed in accordance with 300.4 shall be considered to be supported and secured where such support does not exceed 1.4-m (4½-ft) intervals and the nonmetallic-sheathed cable is securely fastened in place by an approved means within 300 mm (12 in.) of each box, cabinet, conduit body, or other nonmetallic-sheathed cable termination.

FPN: See 314.17(C) for support where nonmetallic boxes are used.

(B) Unsupported Cables. Nonmetallic-sheathed cable shall be permitted to be unsupported where the cable:

- (1) Is fished between access points through concealed spaces in finished buildings or structures and supporting is impracticable.
- (2) Is not more than 1.4 m (4½ ft) from the last point of cable support to the point of connection to a luminaire (lighting fixture) or other piece of electrical equipment and the cable and point of connection are within an accessible ceiling.

(C) Wiring Device Without a Separate Outlet Box. A wiring device identified for the use, without a separate outlet box, and incorporating an integral cable clamp shall be permitted where the cable is secured in place at intervals not exceeding 1.4 m (4½ ft) and within 300 mm (12 in.) from the wiring device wall opening, and there shall be at least a 300 mm (12 in.) loop of unbroken cable or 150 mm (6 in.) of a cable end available on the interior side of the finished wall to permit replacement.

334.40 Boxes and Fittings.

(A) Boxes of Insulating Material. Nonmetallic outlet boxes shall be permitted as provided by 314.3.

(B) Devices of Insulating Material. Switch, outlet, and tap devices of insulating material shall be permitted to be used without boxes in exposed cable wiring and for rewiring in existing buildings where the cable is concealed and fished. Openings in such devices shall form a close fit around the outer covering of the cable, and the device shall fully enclose the part of the cable from which any part of the covering has been removed. Where connections to conductors are by binding-screw terminals, there shall be available as many terminals as conductors.

(C) Devices with Integral Enclosures. Wiring devices with integral enclosures identified for such use shall be permitted as provided by 300.15(E).

334.80 Ampacity. The ampacity of Types NM, NMC, and NMS cable shall be determined in accordance with 310.15. The ampacity shall be in accordance with the 60°C (140°F) conductor temperature rating. The 90°C (194°F) rating shall be permitted to be used for ampacity derating purposes, provided the final derated ampacity does not exceed that for a 60°C (140°F) rated conductor.

Where more than two NM cables containing two or more current-carrying conductors are bundled together and pass through wood framing that is to be fire- or draft-stopped using thermal insulation or sealing foam, the allowable am-

capacity of each conductor shall be adjusted in accordance with Table 310.15(B)(2)(a).

ARTICLE 338

Service-Entrance Cable: Types SE and USE

I. General

338.1 Scope. This article covers the use, installation, and construction specifications of service-entrance cable.

338.2 Definitions.

Service-Entrance Cable. A single conductor or multiconductor assembly provided with or without an overall covering, primarily used for services, and of the following types:

Type SE. Service-entrance cable having a flame-retardant, moisture-resistant covering.

Type USE. Service-entrance cable, identified for underground use, having a moisture-resistant covering, but not required to have a flame-retardant covering.

II. Installation

338.10 Uses Permitted.

(A) Service-Entrance Conductors. Service-entrance cable shall be permitted to be used as service-entrance conductors and shall be installed in accordance with 230.6, 230.7, and Parts II, III, and IV of Article 230.

Type USE used for service laterals shall be permitted to emerge from the ground outside at terminations in meter bases or other enclosures where protected in accordance with 300.5(D).

(B) Branch Circuits or Feeders.

(1) Grounded Conductor Insulated. Type SE service-entrance cables shall be permitted in wiring systems where all of the circuit conductors of the cable are of the rubber-covered or thermoplastic type.

(2) Grounded Conductor Not Insulated. Type SE service-entrance cable shall be permitted for use where the insulated conductors are used for circuit wiring and the uninsulated conductor is used only for equipment grounding purposes.

Exception: Uninsulated conductors shall be permitted as a grounded conductor in accordance with 250.140, 250.32, and 225.30 through 225.39 and 225.40 in the NEC.

(3) Temperature Limitations. Type SE service-entrance cable used to supply appliances shall not be subject to con-

ductor temperatures in excess of the temperature specified for the type of insulation involved.

(4) Installation Methods for Branch Circuits and Feeders.

(a) *Interior Installations.* In addition to the provisions of this article, Type SE service-entrance cable used for interior wiring shall comply with the installation requirements of Parts I and II of Article 334, excluding 334.80.

FPN: See 310.10 for temperature limitation of conductors.

(b) *Exterior Installations.* In addition to the provisions of this article, service-entrance cable used for feeders or branch circuits, where installed as exterior wiring, shall be installed in accordance with Part I of Article 225. The cable shall be supported in accordance with 334.30, unless used as messenger-supported wiring as permitted in Part II of Article 396 in the *NEC*.

Type USE cable installed as underground feeder and branch circuit cable shall comply with Part II of Article 340. Where Type USE cable emerges from the ground at terminations, it shall be protected in accordance with 300.5(D). Multiconductor service-entrance cable shall be permitted to be installed as messenger-supported wiring in accordance with 225.10 and Part II of Article 396 in the *NEC*.

338.24 Bending Radius. Bends in Types USE and SE cable shall be so made that the cable will not be damaged. The radius of the curve of the inner edge of any bend, during or after installation, shall not be less than five times the diameter of the cable.

ARTICLE 340 Underground Feeder and Branch-Circuit Cable: Type UF

I. General

340.1 Scope. This article covers the use, installation, and construction specifications for underground feeder and branch-circuit cable, Type UF.

340.2 Definition.

Underground Feeder and Branch-Circuit Cable, Type UF. A factory assembly of one or more insulated conductors with an integral or an overall covering of nonmetallic material suitable for direct burial in the earth.

340.6 Listing Requirements. Type UF cable shall be listed.

II. Installation

340.10 Uses Permitted. Type UF cable shall be permitted as follows:

- (1) For use underground, including direct burial in the earth. For underground requirements, see 300.5.
- (2) As single-conductor cables. Where installed as single-conductor cables, all conductors of the feeder grounded conductor or branch circuit, including the grounded conductor and equipment grounding conductor, if any, shall be installed in accordance with 300.3.
- (3) For wiring in wet, dry, or corrosive locations under the recognized wiring methods of this *Code*.
- (4) Installed as nonmetallic-sheathed cable. Where so installed, the installation and conductor requirements shall comply with Part II of Article 334, Part III of Article 334 in the *NEC* and shall be of the multiconductor type.
- (5) For solar photovoltaic systems in accordance with 690.31 in the *NEC*.
- (6) As single-conductor cables as the nonheating leads for heating cables as provided in 424.43.

FPN: See 310.10 for temperature limitation of conductors.

340.12 Uses Not Permitted. Type UF cable shall not be used as follows:

- (1) As service-entrance cable
- (8) Embedded in poured cement, concrete, or aggregate, except where embedded in plaster as nonheating leads where permitted in 424.43
- (9) Where exposed to direct rays of the sun, unless identified as sunlight resistant
- (10) Where subject to physical damage
- (11) As overhead cable, except where installed as messenger-supported wiring in accordance with Part II of Article 396 in the *NEC*

340.24 Bending Radius. Bends in Type UF cable shall be so made that the cable is not damaged. The radius of the curve of the inner edge of any bend shall not be less than five times the diameter of the cable.

340.80 Ampacity. The ampacity of Type UF cable shall be that of 60°C (140°F) conductors in accordance with 310.15.

ARTICLE 342 Intermediate Metal Conduit: Type IMC

I. General

342.1 Scope. This article covers the use, installation, and construction specifications for intermediate metal conduit (IMC) and associated fittings.

342.2 Definition.

Intermediate Metal Conduit (IMC). A steel threadable raceway of circular cross section designed for the physical protection and routing of conductors and cables and for use as an equipment grounding conductor when installed with its integral or associated coupling and appropriate fittings.

342.6 Listing Requirements. IMC, factory elbows and couplings, and associated fittings shall be listed.

II. Installation

342.10 Uses Permitted.

(A) All Atmospheric Conditions and Occupancies. Use of IMC shall be permitted under all atmospheric conditions and occupancies.

(B) Corrosion Environments. IMC, elbows, couplings, and fittings shall be permitted to be installed in concrete, in direct contact with the earth, or in areas subject to severe corrosive influences where protected by corrosion protection and judged suitable for the condition.

(C) Cinder Fill. IMC shall be permitted to be installed in or under cinder fill where subject to permanent moisture where protected on all sides by a layer of noncinder concrete not less than 50 mm (2 in.) thick; where the conduit is not less than 450 mm (18 in.) under the fill; or where protected by corrosion protection and judged suitable for the condition.

(D) Wet Locations. All supports, bolts, straps, screws, and so forth, shall be of corrosion-resistant materials or protected against corrosion by corrosion-resistant materials.

FPN: See 300.6 for protection against corrosion.

342.14 Dissimilar Metals. Where practicable, dissimilar metals in contact anywhere in the system shall be avoided to eliminate the possibility of galvanic action.

Aluminum fittings and enclosures shall be permitted to be used with IMC.

342.20 Size.

(A) Minimum. IMC smaller than metric designator 16 (trade size ½) shall not be used.

(B) Maximum. IMC larger than metric designator 103 (trade size 4) shall not be used.

FPN: See 300.1(C) for the metric designators and trade sizes. These are for identification purposes only and do not relate to actual dimensions.

342.22 Number of Conductors. The number of conductors shall not exceed that permitted by the percentage fill specified in Table 1, Chapter 9.

Cables shall be permitted to be installed where such use is not prohibited by the respective cable articles. The number of cables shall not exceed the allowable percentage fill specified in Table 1, Chapter 9.

342.24 Bends — How Made. Bends of IMC shall be so made that the conduit will not be damaged and the internal diameter of the conduit will not be effectively reduced. The radius of the curve of any field bend to the centerline of the conduit shall not be less than indicated in Table 2, Chapter 9.

342.26 Bends — Number in One Run. There shall not be more than the equivalent of four quarter bends (360 degrees total) between pull points, for example, conduit bodies and boxes.

342.28 Reaming and Threading. All cut ends shall be reamed or otherwise finished to remove rough edges. Where conduit is threaded in the field, a standard cutting die with a taper of 1 in 16 (¾ in. taper per foot) shall be used.

FPN: See ANSI/ASME B.1.20.1-1983, *Standard for Pipe Threads, General Purpose (Inch)*.

342.30 Securing and Supporting. IMC shall be installed as a complete system in accordance with 300.18 and shall be securely fastened in place and supported in accordance with 342.30(A) and (B).

(A) Securely Fastened. Each IMC shall be securely fastened within 900 mm (3 ft) of each outlet box, junction box, device box, cabinet, conduit body, or other conduit termination. Fastening shall be permitted to be increased to a distance of 1.5 m (5 ft) where structural members do not readily permit fastening within 900 mm (3 ft). Where approved, conduit shall not be required to be securely fastened within 900 mm (3 ft) of the service head for above-the-roof termination of a mast.

(B) Supports. IMC shall be supported in accordance with one of the following:

- (1) Conduit shall be supported at intervals not exceeding 3 m (10 ft).
- (2) The distance between supports for straight runs of conduit shall be permitted in accordance with Table 344.30(B)(2), provided the conduit is made up with threaded couplings and such supports prevent transmission of stresses to termination where conduit is deflected between supports.
- (3) Exposed vertical risers from industrial machinery or fixed equipment shall be permitted to be supported at intervals not exceeding 6 m (20 ft) if the conduit is made up with threaded couplings, the conduit is supported and

securely fastened at the top and bottom of the riser, and no other means of intermediate support is readily available.

- (4) Horizontal runs of IMC supported by openings through framing members at intervals not exceeding 3 m (10 ft) and securely fastened within 900 mm (3 ft) of termination points shall be permitted.

342.42 Couplings and Connectors.

(A) **Threadless.** Threadless couplings and connectors used with conduit shall be made tight. Where buried in masonry or concrete, they shall be the concretetight type. Where installed in wet locations, they shall comply with 314.15(A). Threadless couplings and connectors shall not be used on threaded conduit ends unless listed for the purpose.

(B) **Running Threads.** Running threads shall not be used on conduit for connection at couplings.

342.46 Bushings. Where a conduit enters a box, fitting, or other enclosure, a bushing shall be provided to protect the wire from abrasion unless the design of the box, fitting, or enclosure is such as to afford equivalent protection.

FPN: See 300.4(F) for the protection of conductors 4 AWG and larger at bushings.

342.56 Splices and Taps. Splices and taps shall be made in accordance with 300.15.

342.60 Grounding. IMC shall be permitted as an equipment grounding conductor.

ARTICLE 344 Rigid Metal Conduit: Type RMC

I. General

344.1 Scope. This article covers the use, installation, and construction specifications for rigid metal conduit (RMC) and associated fittings.

344.2 Definition.

Rigid Metal Conduit (RMC). A threadable raceway of circular cross section designed for the physical protection and routing of conductors and cables and for use as an equipment grounding conductor when installed with its integral or associated coupling and appropriate fittings. RMC is generally made of steel (ferrous) with protective coatings or aluminum (nonferrous). Special use types are silicon bronze and stainless steel.

344.6 Listing Requirements. RMC, factory elbows and couplings, and associated fittings shall be listed.

II. Installation

344.10 Uses Permitted.

(A) **All Atmospheric Conditions and Occupancies.** Use of RMC shall be permitted under all atmospheric conditions and occupancies. Ferrous raceways and fittings protected from corrosion solely by enamel shall be permitted only indoors and in occupancies not subject to severe corrosive influences.

(B) **Corrosion Environments.** RMC, elbows, couplings, and fittings shall be permitted to be installed in concrete, in direct contact with the earth, or in areas subject to severe corrosive influences where protected by corrosion protection and judged suitable for the condition.

(C) **Cinder Fill.** RMC shall be permitted to be installed in or under cinder fill where subject to permanent moisture where protected on all sides by a layer of noncinder concrete not less than 50 mm (2 in.) thick; where the conduit is not less than 450 mm (18 in.) under the fill; or where protected by corrosion protection and judged suitable for the condition.

(D) **Wet Locations.** All supports, bolts, straps, screws, and so forth, shall be of corrosion-resistant materials or protected against corrosion by corrosion-resistant materials.

FPN: See 300.6 for protection against corrosion.

344.14 Dissimilar Metals. Where practicable, dissimilar metals in contact anywhere in the system shall be avoided to eliminate the possibility of galvanic action. Aluminum fittings and enclosures shall be permitted to be used with steel RMC, and steel fittings and enclosures shall be permitted to be used with aluminum RMC where not subject to severe corrosive influences.

344.20 Size.

(A) **Minimum.** RMC smaller than metric designator 16 (trade size ½) shall not be used.

Exception: For enclosing the leads of motors as permitted in 430.245(B) in the NEC.

(B) **Maximum.** RMC larger than metric designator 155 (trade size 6) shall not be used.

FPN: See 300.1(C) for the metric designators and trade sizes. These are for identification purposes only and do not relate to actual dimensions.

344.22 Number of Conductors. The number of conductors shall not exceed that permitted by the percentage fill specified in Table 1, Chapter 9.

Cables shall be permitted to be installed where such use is not prohibited by the respective cable articles. The

number of cables shall not exceed the allowable percentage fill specified in Table 1, Chapter 9.

344.24 Bends — How Made. Bends of RMC shall be so made that the conduit will not be damaged and so that the internal diameter of the conduit will not be effectively reduced. The radius of the curve of any field bend to the centerline of the conduit shall not be less than indicated in Table 2, Chapter 9.

344.26 Bends — Number in One Run. There shall not be more than the equivalent of four quarter bends (360 degrees total) between pull points, for example, conduit bodies and boxes.

344.28 Reaming and Threading. All cut ends shall be reamed or otherwise finished to remove rough edges. Where conduit is threaded in the field, a standard cutting die with a 1 in 16 taper ($\frac{3}{4}$ -in. taper per foot) shall be used.

FPN: See ANSI/ASME B.1.20.1-1983, *Standard for Pipe Threads, General Purpose (Inch)*.

344.30 Securing and Supporting. RMC shall be installed as a complete system in accordance with 300.18 and shall be securely fastened in place and supported in accordance with 344.30(A) and (B).

(A) Securely Fastened. RMC shall be securely fastened within 900 mm (3 ft) of each outlet box, junction box, device box, cabinet, conduit body, or other conduit termination. Fastening shall be permitted to be increased to a distance of 1.5 m (5 ft) where structural members do not readily permit fastening within 900 mm (3 ft). Where approved, conduit shall not be required to be securely fastened within 900 mm (3 ft) of the service head for above-the-roof termination of a mast.

(B) Supports. RMC shall be supported in accordance with one of the following:

- (1) Conduit shall be supported at intervals not exceeding 3 m (10 ft).
- (2) The distance between supports for straight runs of conduit shall be permitted in accordance with Table 344.30(B)(2), provided the conduit is made up with threaded couplings, and such supports prevent transmission of stresses to termination where conduit is deflected between supports.
- (3) Exposed vertical risers from industrial machinery or fixed equipment shall be permitted to be supported at intervals not exceeding 6 m (20 ft) if the conduit is made up with threaded couplings, the conduit is supported and securely fastened at the top and bottom of the riser,

and no other means of intermediate support is readily available.

- (4) Horizontal runs of RMC supported by openings through framing members at intervals not exceeding 3 m (10 ft) and securely fastened within 900 mm (3 ft) of termination points shall be permitted.

Table 344.30(B)(2) Supports for Rigid Metal Conduit

Conduit Size		Maximum Distance Between Rigid Metal Conduit Supports	
Metric Designator	Trade Size	m	ft
16-21	$\frac{1}{2}$ - $\frac{3}{4}$	3.0	10
27	1	3.7	12
35-41	$1\frac{1}{4}$ - $1\frac{1}{2}$	4.3	14
53-63	2- $2\frac{1}{2}$	4.9	16
78 and larger	3 and larger	6.1	20

344.42 Couplings and Connectors.

(A) Threadless. Threadless couplings and connectors used with conduit shall be made tight. Where buried in masonry or concrete, they shall be the concretetight type. Where installed in wet locations, they shall comply with 314.15(A). Threadless couplings and connectors shall not be used on threaded conduit ends unless listed for the purpose.

(B) Running Threads. Running threads shall not be used on conduit for connection at couplings.

344.46 Bushings. Where a conduit enters a box, fitting, or other enclosure, a bushing shall be provided to protect the wire from abrasion unless the design of the box, fitting, or enclosure is such as to afford equivalent protection.

FPN: See 300.4(F) for the protection of conductors sizes 4 AWG and larger at bushings.

344.56 Splices and Taps. Splices and taps shall be made in accordance with 300.15.

344.60 Grounding. RMC shall be permitted as an equipment grounding conductor.

ARTICLE 348 Flexible Metal Conduit: Type FMC

I. General

348.1 Scope. This article covers the use, installation, and construction specifications for flexible metal conduit (FMC) and associated fittings.

348.2 Definition.

Flexible Metal Conduit (FMC). A raceway of circular cross section made of helically wound, formed, interlocked metal strip.

348.6 Listing Requirements. FMC and associated fittings shall be listed.

II. Installation

348.10 Uses Permitted. FMC shall be permitted to be used in exposed and concealed locations.

348.12 Uses Not Permitted. FMC shall not be used in the following:

- (1) In wet locations unless the conductors are approved for the specific conditions and the installation is such that liquid is not likely to enter raceways or enclosures to which the conduit is connected
- (6) Underground or embedded in poured concrete or aggregate
- (7) Where subject to physical damage

348.20 Size.

(A) Minimum. FMC less than metric designator 16 (trade size 1/2) shall not be used unless permitted in 348.20(A)(1) and (A)(2) for metric designator 12 (trade size).

- (1) For enclosing the leads of motors as permitted in 430.245(B) in the *NEC*
- (2) In lengths not in excess of 1.8 m (6 ft) for any of the following uses:
 - a. For utilization equipment
 - b. As part of a listed assembly
 - c. For tap connections to luminaires (lighting fixtures) as permitted in 410.67(C)

(B) Maximum. FMC larger than metric designator 103 (trade size 4) shall not be used.

FPN: See 300.1(C) for the metric designators and trade sizes. These are for identification purposes only and do not relate to actual dimensions.

348.22 Number of Conductors. The number of conductors shall not exceed that permitted by the percentage fill specified in Table 1, Chapter 9, or as permitted in Table 348.22, or for metric designator 12 (trade size 3/8).

Cables shall be permitted to be installed where such use is not prohibited by the respective cable articles. The number of cables shall not exceed the allowable percentage fill specified in Table 1, Chapter 9.

348.24 Bends — How Made. Bends in conduit shall be made so that the conduit is not damaged and the internal diameter of the conduit is not effectively reduced. Bends shall be permitted to be made manually without auxiliary equipment. The radius of the curve to the centerline of any bend shall not be less than shown in Table 2, Chapter 9 using the column “Other Bends.”

348.26 Bends — Number in One Run. There shall not be more than the equivalent of four quarter bends (360 degrees total) between pull points, for example, conduit bodies and boxes.

348.28 Trimming. All cut ends shall be trimmed or otherwise finished to remove rough edges, except where fittings that thread into the convolutions are used.

348.30 Securing and Supporting. FMC shall be securely fastened in place and supported in accordance with 348.30(A) and (B).

(A) Securely Fastened. FMC shall be securely fastened in place by an approved means within 300 mm (12 in.) of each

Table 348.22 Maximum Number of Insulated Conductors in Metric Designator 12 (Trade Size 3/8) Flexible Metal Conduit*

Size (AWG)	Types RFH-2, SF-2		Types TF, XHHW, TW		Types TFN, THHN, THWN		Types FEP, FEBP, PF, PGF	
	Fittings Inside Conduit	Fittings Outside Conduit	Fittings Inside Conduit	Fittings Outside Conduit	Fittings Inside Conduit	Fittings Outside Conduit	Fittings Inside Conduit	Fittings Outside Conduit
18	2	3	3	5	5	8	5	8
16	1	2	3	4	4	6	4	6
14	1	2	2	3	3	4	3	4
12	—	—	1	2	2	3	2	3
10	—	—	1	1	1	1	1	2

*In addition, one covered or bare equipment grounding conductor of the same size shall be permitted.

box, cabinet, conduit body, or other conduit termination and shall be supported and secured at intervals not to exceed 1.4 m (4½ ft).

Exception No. 1: Where FMC is fished.

Exception No. 2: At terminals where flexibility is required, lengths shall not exceed the following:

- (a) 900 mm (3 ft) for metric designators 16 through 35 (trade sizes ½ through 1¼)
- (b) 1200 mm (4 ft) for metric designators 41 through 53 (trade sizes 1½ through 2)
- (c) 1500 mm (5 ft) for metric designators 63 (trade size 2½) and larger

Exception No. 3: Lengths not exceeding 1.8 m (6 ft) from a luminaire (fixture) terminal connection for tap connections to luminaires (light fixtures) as permitted in 410.67(C).

Exception No. 4: Lengths not exceeding 1.8 m (6 ft) from the last point where the raceway is securely fastened for connections within an accessible ceiling to luminaire(s) [lighting fixture(s)] or other equipment.

(B) Supports. Horizontal runs of FMC supported by openings through framing members at intervals not greater than 1.4 m (4½ ft) and securely fastened within 300 mm (12 in.) of termination points shall be permitted.

348.42 Couplings and Connectors. Angle connectors shall not be used for concealed raceway installations.

348.56 Splices and Taps. Splices and taps shall be made in accordance with 300.15.

348.60 Grounding and Bonding. Where used to connect equipment where flexibility is required, an equipment grounding conductor shall be installed.

Where flexibility is not required, FMC shall be permitted to be used as an equipment grounding conductor when installed in accordance with 250.118(5).

Where required or installed, equipment grounding conductors shall be installed in accordance with 250.134(B).

Where required or installed, equipment bonding jumpers shall be installed in accordance with 250.102.

ARTICLE 350
Liquidtight Flexible Metal Conduit:
Type LFMC

I. General

350.1 Scope. This article covers the use, installation, and construction specifications for liquidtight flexible metal conduit (LFMC) and associated fittings.

350.2 Definition.

Liquidtight Flexible Metal Conduit (LFMC). A raceway of circular cross section having an outer liquidtight, nonmetallic, sunlight-resistant jacket over an inner flexible metal core with associated couplings, connectors, and fittings for the installation of electric conductors.

350.6 Listing Requirements. LFMC and associated fittings shall be listed.

II. Installation

350.10 Uses Permitted. LFMC shall be permitted to be used in exposed or concealed locations as follows:

- (1) Where conditions of installation, operation, or maintenance require flexibility or protection from liquids, vapors, or solids
- (3) For direct burial where listed and marked for the purpose

350.12 Uses Not Permitted. LFMC shall not be used as follows:

- (1) Where subject to physical damage
- (2) Where any combination of ambient and conductor temperature produces an operating temperature in excess of that for which the material is approved

350.20 Size.

(A) Minimum. LFMC smaller than metric designator 16 (trade size ½) shall not be used.

Exception: LFMC of metric designator 12 (trade size ¾) shall be permitted as covered in 348.20(A).

(B) Maximum. The maximum size of LFMC shall be metric designator 103 (trade size 4).

FPN: See 300.1(C) for the metric designators and trade sizes. These are for identification purposes only and do not relate to actual dimensions.

350.22 Number of Conductors or Cables.

(A) Metric Designators 16 Through 103 (trade sizes ½ through 4). The number of conductors shall not exceed that permitted by the percentage fill specified in Table 1, Chapter 9.

Cables shall be permitted to be installed where such use is not prohibited by the respective cable articles. The number of cables shall not exceed the allowable percentage fill specified in Table 1, Chapter 9.

(B) Metric Designator 12 (trade size ¾). The number of conductors shall not exceed that permitted in Table 348.22, "Fittings Outside Conduit" columns.

350.24 Bends — How Made. Bends in conduit shall be so made that the conduit will not be damaged and the internal diameter of the conduit will not be effectively reduced. Bends shall be permitted to be made manually without auxiliary equipment. The radius of the curve to the centerline of any bend shall not be less than required in Table 2, Chapter 9 using the column “Other Bends.”

350.26 Bends — Number in One Run. There shall not be more than the equivalent of four quarter bends (360 degrees total) between pull points, for example, conduit bodies and boxes.

350.30 Securing and Supporting. LFMC shall be securely fastened in place and supported in accordance with 350.30(A) and (B).

(A) Securely Fastened. LFMC shall be securely fastened in place by an approved means within 300 mm (12 in.) of each box, cabinet, conduit body, or other conduit termination and shall be supported and secured at intervals not to exceed 1.4 m (4½ ft).

Exception No. 1: Where LFMC is fished.

Exception No. 2: Lengths not exceeding 900 mm (3 ft) at terminals where flexibility is necessary.

Exception No. 3: Lengths not exceeding 1.8 m (6 ft) from a luminaire (fixture) terminal connection for tap conductors to luminaires (lighting fixtures), as permitted in 410.67(C).

Exception No. 4: Lengths not exceeding 1.8 m (6 ft) from the last point where the raceway is securely fastened for connections within an accessible ceiling to luminaire(s) [lighting fixture(s)] or other equipment.

(B) Supports. Horizontal runs of LFMC supported by openings through framing members at intervals not greater than 1.4 m (4½ ft) and securely fastened within 300 mm (12 in.) of termination points shall be permitted.

350.42 Couplings and Connectors. Angle connectors shall not be used for concealed raceway installations.

350.56 Splices and Taps. Splices and taps shall be made in accordance with 300.15.

350.60 Grounding and Bonding. Where used to connect equipment where flexibility is required, an equipment grounding conductor shall be installed.

Where flexibility is not required, LFMC shall be permitted to be used as an equipment grounding conductor when installed in accordance with 250.118(6).

Where required or installed, equipment grounding conductors shall be installed in accordance with 250.134(B).

Where required or installed, equipment bonding jumpers shall be installed in accordance with 250.102.

ARTICLE 352 Rigid Nonmetallic Conduit: Type RNC

I. General

352.1 Scope. This article covers the use, installation, and construction specifications for rigid nonmetallic conduit (RNC) and associated fittings.

352.2 Definition.

Rigid Nonmetallic Conduit (RNC). A nonmetallic raceway of circular cross section, with integral or associated couplings, connectors, and fittings for the installation of electrical conductors and cables.

352.6 Listing Requirements. RNC, factory elbows, and associated fittings shall be listed.

II. Installation

352.10 Uses Permitted. The use of RNC shall be permitted in accordance with 352.10(A) through (H).

FPN: Extreme cold may cause some nonmetallic conduits to become brittle and therefore more susceptible to damage from physical contact.

(A) Concealed. RNC shall be permitted in walls, floors, and ceilings.

(B) Corrosive Influences. RNC shall be permitted in locations subject to severe corrosive influences as covered in 300.6 and where subject to chemicals for which the materials are specifically approved.

(C) Cinders. RNC shall be permitted in cinder fill.

(D) Wet Locations. RNC shall be permitted in portions of dairies, laundries, canneries, or other wet locations and in locations where walls are frequently washed, the entire conduit system including boxes and fittings used therewith shall be installed and equipped so as to prevent water from entering the conduit. All supports, bolts, straps, screws, and so forth, shall be of corrosion-resistant materials or be protected against corrosion by approved corrosion-resistant materials.

(E) Dry and Damp Locations. RNC shall be permitted for use in dry and damp locations not prohibited by 352.12.

(F) Exposed. RNC shall be permitted for exposed work where not subject to physical damage if identified for such use.

(G) Underground Installations. For underground installations, see 300.5.

FPN: Refer to Article 353 in the *NEC* for High Density Polyethylene Conduit: Type HDPE.

(H) Support of Conduit Bodies. Rigid nonmetallic conduit shall be permitted to support nonmetallic conduit bodies not larger than the largest trade size of an entering raceway. These conduit bodies shall not support luminaires (fixtures) or other equipment and shall not contain devices other than splicing devices as permitted by 110.14(B) and 314.16(C)(2).

352.12 Uses Not Permitted. RNC shall not be used under the following conditions.

(B) Support of Luminaires (Fixtures). For the support of luminaires (fixtures) or other equipment not described in 352.10(H).

(C) Physical Damage. Where subject to physical damage unless identified for such use.

(D) Ambient Temperatures. Where subject to ambient temperatures in excess of 50°C (122°F) unless listed otherwise.

(E) Insulation Temperature Limitations. For conductors or cables operating at a temperature higher than the RNC listed operating temperature rating.

Exception: Conductors or cables rated at a temperature higher than the RNC listed temperature rating shall be permitted to be installed in RNC, provided they are not operated at a temperature higher than the RNC listed temperature rating.

352.20 Size.

(A) Minimum. RNC smaller than metric designator 16 (trade size ½) shall not be used.

(B) Maximum. RNC larger than metric designator 155 (trade size 6) shall not be used.

FPN: The trade sizes and metric designators are for identification purposes only and do not relate to actual dimensions. See 300.1(C).

352.22 Number of Conductors. The number of conductors shall not exceed that permitted by the percentage fill specified in Table 1, Chapter 9.

Cables shall be permitted to be installed where such use is not prohibited by the respective cable articles. The number of cables shall not exceed the allowable percentage fill specified in Table 1, Chapter 9.

352.24 Bends — How Made. Bends shall be so made that the conduit will not be damaged and the internal diameter of the conduit will not be effectively reduced. Field bends shall be made only with bending equipment identified for the purpose. The radius of the curve to the centerline of such bends shall not be less than shown in Table 2, Chapter 9.

352.26 Bends — Number in One Run. There shall not be more than the equivalent of four quarter bends (360 degrees total) between pull points, for example, conduit bodies and boxes.

352.28 Trimming. All cut ends shall be trimmed inside and outside to remove rough edges.

352.30 Securing and Supporting. RNC shall be installed as a complete system as provided in 300.18 and shall be fastened so that movement from thermal expansion or contraction is permitted. RNC shall be securely fastened and supported in accordance with 352.30(A) and (B).

(A) Securely Fastened. RNC shall be securely fastened within 900 mm (3 ft) of each outlet box, junction box, device box, conduit body, or other conduit termination. Conduit listed for securing at other than 900 mm (3 ft) shall be permitted to be installed in accordance with the listing.

(B) Supports. RNC shall be supported as required in Table 352.30(B). Conduit listed for support at spacings other than as shown in Table 352.30(B) shall be permitted to be installed in accordance with the listing. Horizontal runs of RNC supported by openings through framing members at intervals not exceeding those in Table 352.30(B) and securely fastened within 900 mm (3 ft) of termination points shall be permitted.

352.44 Expansion Fittings. Expansion fittings for RNC shall be provided to compensate for thermal expansion and contraction where the length change, in accordance with Table 352.44(A) or Table 352.44(B), is expected to be 6 mm (¼ in.) or greater in a straight run between securely

Table 352.30(B) Support of Rigid Nonmetallic Conduit (RNC)

Conduit Size		Maximum Spacing Between Supports	
Metric Designator	Trade Size	mm or m	ft
16–27	½–1	900 mm	3
35–53	1¼–2	1.5 m	5
63–78	2½–3	1.8 m	6
91–129	3½–5	2.1 m	7
155	6	2.5 m	8

mounted items such as boxes, cabinets, elbows, or other conduit terminations.

352.46 Bushings. Where a conduit enters a box, fitting, or other enclosure, a bushing or adapter shall be provided to protect the wire from abrasion unless the box, fitting, or enclosure design provides equivalent protection.

FPN: See 300.4(F) for the protection of conductors 4 AWG and larger at bushings.

352.48 Joints. All joints between lengths of conduit, and between conduit and couplings, fittings, and boxes, shall be made by an approved method.

352.56 Splices and Taps. Splices and taps shall be made in accordance with 300.15.

352.60 Grounding. Where equipment grounding is required, a separate equipment grounding conductor shall be installed in the conduit.

Exception No. 1: As permitted in 250.134(B), Exception No. 2 in the NEC, for dc circuits and 250.134(B), Exception No. 1, for separately run equipment grounding conductors.

Exception No. 2: Where the grounded conductor is used to ground equipment as permitted in 250.142.

ARTICLE 356
Liquidtight Flexible Nonmetallic Conduit:
Type LFNC

I. General

356.1 Scope. This article covers the use, installation, and construction specifications for liquidtight flexible nonmetallic conduit (LFNC) and associated fittings.

356.2 Definition.

Liquidtight Flexible Nonmetallic Conduit (LFNC). A raceway of circular cross section of various types as follows:

- (1) A smooth seamless inner core and cover bonded together and having one or more reinforcement layers between the core and covers, designated as Type LFNC-A
- (2) A smooth inner surface with integral reinforcement within the conduit wall, designated as Type LFNC-B
- (3) A corrugated internal and external surface without integral reinforcement within the conduit wall, designated as LFNC-C

Table 352.44(A) Expansion Characteristics of PVC Rigid Nonmetallic Conduit Coefficient of Thermal Expansion = 6.084×10^{-5} mm/mm/°C (3.38×10^{-5} in./in./°F)

Temperature Change (°C)	Length Change of PVC Conduit (mm/m)	Temperature Change (°F)	Length Change of PVC Conduit (in./100 ft)	Temperature Change (°F)	Length Change of PVC Conduit (in./100 ft)
5	0.30	5	0.20	105	4.26
10	0.61	10	0.41	110	4.46
15	0.91	15	0.61	115	4.66
20	1.22	20	0.81	120	4.87
25	1.52	25	1.01	125	5.07
30	1.83	30	1.22	130	5.27
35	2.13	35	1.42	135	5.48
40	2.43	40	1.62	140	5.68
45	2.74	45	1.83	145	5.88
50	3.04	50	2.03	150	6.08
55	3.35	55	2.23	155	6.29
60	3.65	60	2.43	160	6.49
65	3.95	65	2.64	165	6.69
70	4.26	70	2.84	170	6.90
75	4.56	75	3.04	175	7.10
80	4.87	80	3.24	180	7.30
85	5.17	85	3.45	185	7.50
90	5.48	90	3.65	190	7.71
95	5.78	95	3.85	195	7.91
100	6.08	100	4.06	200	8.11

Table 352.44(B) Expansion Characteristics of Reinforced Thermosetting Resin Conduit (RTRC) Coefficient of Thermal Expansion = 2.7×10^{-5} mm/mm/°C (1.5×10^{-5} in./in./°F)

Temperature Change (°C)	Length Change of RTRC Conduit (mm/m)	Temperature Change (°F)	Length Change of RTRC Conduit (in./100 ft)	Temperature Change (°F)	Length Change of RTRC Conduit (in./100 ft)
5	0.14	5	0.09	105	1.89
10	0.27	10	0.18	110	1.98
15	0.41	15	0.27	115	2.07
20	0.54	20	0.36	120	2.16
25	0.68	25	0.45	125	2.25
30	0.81	30	0.54	130	2.34
35	0.95	35	0.63	135	2.43
40	1.08	40	0.72	140	2.52
45	1.22	45	0.81	145	2.61
50	1.35	50	0.90	150	2.70
55	1.49	55	0.99	155	2.79
60	1.62	60	1.08	160	2.88
65	1.76	65	1.17	165	2.97
70	1.89	70	1.26	170	3.06
75	2.03	75	1.35	175	3.15
80	2.16	80	1.44	180	3.24
85	2.30	85	1.53	185	3.33
90	2.43	90	1.62	190	3.42
95	2.57	95	1.71	195	3.51
100	2.70	100	1.80	200	3.60

LFNC is flame resistant and with fittings and is approved for the installation of electrical conductors.

FPN: FNMC is an alternative designation for LFNC.

356.6 Listing Requirements. LFNC and associated fittings shall be listed.

II. Installation

356.10 Uses Permitted. LFNC shall be permitted to be used in exposed or concealed locations for the following purposes:

FPN: Extreme cold may cause some types of nonmetallic conduits to become brittle and therefore more susceptible to damage from physical contact.

- (1) Where flexibility is required for installation, operation, or maintenance
- (2) Where protection of the contained conductors is required from vapors, liquids, or solids
- (3) For outdoor locations where listed and marked as suitable for the purpose
- (4) For direct burial where listed and marked for the purpose
- (5) Type LFNC-B shall be permitted to be installed in

lengths longer than 1.8 m (6 ft) where secured in accordance with 356.30

356.12 Uses Not Permitted. LFNC shall not be used as follows:

- (1) Where subject to physical damage
- (2) Where any combination of ambient and conductor temperatures is in excess of that for which the LFNC is approved
- (3) In lengths longer than 1.8 m (6 ft), except as permitted by 356.10(5) or where a longer length is approved as essential for a required degree of flexibility

356.20 Size.

(A) Minimum. LFNC smaller than metric designator 16 (trade size ½) shall not be used unless permitted in 356.20(A)(1) and (A)(2) for metric designator 12 (trade size ⅜).

- (1) For enclosing the leads of motors as permitted in 430.245(B) in the *NEC*
- (2) In lengths not exceeding 1.8 m (6 ft) as part of a listed assembly for tap connections to luminaires (lighting fixtures) as required in 410.67(C), or for utilization equipment

(B) Maximum. LFNC larger than metric designator 103 (trade size 4) shall not be used.

FPN: See 300.1(C) for the metric designators and trade sizes. These are for identification purposes only and do not relate to actual dimensions.

356.22 Number of Conductors. The number of conductors shall not exceed that permitted by the percentage fill specified in Table 1, Chapter 9.

Cables shall be permitted to be installed where such use is not prohibited by the respective cable articles. The number of cables shall not exceed the allowable percentage fill specified in Table 1, Chapter 9.

356.24 Bends — How Made. Bends in conduit shall be so made that the conduit is not damaged and the internal diameter of the conduit is not effectively reduced. Bends shall be permitted to be made manually without auxiliary equipment. The radius of the curve to the centerline of any bend shall not be less than shown in Table 2, Chapter 9 using the column “Other Bends.”

356.26 Bends — Number in One Run. There shall not be more than the equivalent of four quarter bends (360 degrees total) between pull points, for example, conduit bodies and boxes.

356.28 Trimming. All cut ends of conduit shall be trimmed inside and outside to remove rough edges.

356.30 Securing and Supporting. Type LFNC-B shall be securely fastened and supported in accordance with one of the following:

- (1) Where installed in lengths exceeding 1.8 m (6 ft), the conduit shall be securely fastened at intervals not exceeding 900 mm (3 ft) and within 300 mm (12 in.) on each side of every outlet box, junction box, cabinet, or fitting.
- (2) Securing or supporting of the conduit shall not be required where it is fished, installed in lengths not exceeding 900 mm (3 ft) at terminals where flexibility is required, or installed in lengths not exceeding 1.8 m (6 ft) from a luminaire (fixture) terminal connection for tap conductors to luminaires (lighting fixtures) permitted in 410.67(C).
- (3) Horizontal runs of LFNC supported by openings through framing members at intervals not exceeding 900 mm (3 ft) and securely fastened within 300 mm (12 in.) of termination points shall be permitted.
- (4) Securing or supporting of LFNC-B shall not be required where installed in lengths not exceeding 1.8 m (6 ft) from the last point where the raceway is securely fas-

tened for connections within an accessible ceiling to luminaire(s) [lighting fixture(s)] or other equipment.

356.42 Couplings and Connectors. Only fittings listed for use with LFNC shall be used. Angle connectors shall not be used for concealed raceway installations. Straight LFNC fittings are permitted for direct burial or encasement in concrete.

356.56 Splices and Taps. Splices and taps shall be made in accordance with 300.15.

356.60 Grounding and Bonding. Where used to connect equipment where flexibility is required, an equipment grounding conductor shall be installed.

Where required or installed, equipment grounding conductors shall be installed in accordance with 250.134(B).

Where required or installed, equipment bonding jumpers shall be installed in accordance with 250.102.

ARTICLE 358 Electrical Metallic Tubing: Type EMT

I. General

358.1 Scope. This article covers the use, installation, and construction specifications for electrical metallic tubing (EMT) and associated fittings.

358.2 Definition.

Electrical Metallic Tubing (EMT). An unthreaded thin-wall raceway of circular cross section designed for the physical protection and routing of conductors and cables and for use as an equipment grounding conductor when installed utilizing appropriate fittings. EMT is generally made of steel (ferrous) with protective coatings or aluminum (nonferrous).

358.6 Listing Requirements. EMT, factory elbows, and associated fittings shall be listed.

II. Installation

358.10 Uses Permitted.

(A) Exposed and Concealed. The use of EMT shall be permitted for both exposed and concealed work.

(B) Corrosion Protection. Ferrous or nonferrous EMT, elbows, couplings, and fittings shall be permitted to be installed in concrete, in direct contact with the earth, or in areas subject to severe corrosive influences where protected by corrosion protection and judged suitable for the condition.

(C) Wet Locations. All supports, bolts, straps, screws, and so forth shall be of corrosion-resistant materials or protected against corrosion by corrosion-resistant materials.

FPN: See 300.6 for protection against corrosion.

358.12 Uses Not Permitted. EMT shall not be used under the following conditions:

- (1) Where, during installation or afterward, it will be subject to severe physical damage
- (2) Where protected from corrosion solely by enamel
- (3) In cinder concrete or cinder fill where subject to permanent moisture unless protected on all sides by a layer of noncinder concrete at least 50 mm (2 in.) thick or unless the tubing is at least 450 mm (18 in.) under the fill
- (5) For the support of luminaires (fixtures) or other equipment except conduit bodies no larger than the largest trade size of the tubing
- (6) Where practicable, dissimilar metals in contact anywhere in the system shall be avoided to eliminate the possibility of galvanic action

Exception: Aluminum fittings and enclosures shall be permitted to be used with steel EMT where not subject to severe corrosive influences.

358.20 Size.

(A) Minimum. EMT smaller than metric designator 16 (trade size ½) shall not be used.

Exception: For enclosing the leads of motors as permitted in 430.245(B) in the NEC.

(B) Maximum. The maximum size of EMT shall be metric designator 103 (trade size 4).

FPN: See 300.1(C) for the metric designators and trade sizes. These are for identification purposes only and do not relate to actual dimensions.

358.22 Number of Conductors. The number of conductors shall not exceed that permitted by the percentage fill specified in Table 1, Chapter 9.

Cables shall be permitted to be installed where such use is not prohibited by the respective cable articles. The number of cables shall not exceed the allowable percentage fill specified in Table 1, Chapter 9.

358.24 Bends — How Made. Bends shall be made so that the tubing is not damaged and the internal diameter of the tubing is not effectively reduced. The radius of the curve of any field bend to the centerline of the tubing shall not be less than shown in Table 2, Chapter 9 for one-shot and full shoe benders.

358.26 Bends — Number in One Run. There shall not be more than the equivalent of four quarter bends (360 degrees total) between pull points, for example, conduit bodies and boxes.

358.28 Reaming and Threading.

(A) Reaming. All cut ends of EMT shall be reamed or otherwise finished to remove rough edges.

(B) Threading. EMT shall not be threaded.

Exception: EMT with factory threaded integral couplings complying with 358.100 in the NEC.

358.30 Securing and Supporting. EMT shall be installed as a complete system in accordance with 300.18 and shall be securely fastened in place and supported in accordance with 358.30(A) and (B).

(A) Securely Fastened. EMT shall be securely fastened in place at least every 3 m (10 ft). In addition, each EMT run between termination points shall be securely fastened within 900 mm (3 ft) of each outlet box, junction box, device box, cabinet, conduit body, or other tubing termination.

Exception No. 1: Fastening of unbroken lengths shall be permitted to be increased to a distance of 1.5 m (5 ft) where structural members do not readily permit fastening within 900 mm (3 ft).

Exception No. 2: For concealed work in finished buildings or prefinished wall panels where such securing is impracticable, unbroken lengths (without coupling) of EMT shall be permitted to be fished.

(B) Supports. Horizontal runs of EMT supported by openings through framing members at intervals not greater than 3 m (10 ft) and securely fastened within 900 mm (3 ft) of termination points shall be permitted.

358.42 Couplings and Connectors. Couplings and connectors used with EMT shall be made up tight. Where buried in masonry or concrete, they shall be concretetight type. Where installed in wet locations, they shall comply with 314.15(A).

358.56 Splices and Taps. Splices and taps shall be made in accordance with 300.15.

358.60 Grounding. EMT shall be permitted as an equipment grounding conductor.

ARTICLE 362

Electrical Nonmetallic Tubing: Type ENT

I. General

362.1 Scope. This article covers the use, installation, and construction specifications for electrical nonmetallic tubing (ENT) and associated fittings.

362.2 Definition.

Electrical Nonmetallic Tubing (ENT). A nonmetallic pliable corrugated raceway of circular cross section with integral or associated couplings, connectors, and fittings for the installation of electric conductors. ENT is composed of a material that is resistant to moisture and chemical atmospheres and is flame retardant.

A pliable raceway is a raceway that can be bent by hand with a reasonable force but without other assistance.

362.6 Listing Requirements. ENT and associated fittings shall be listed.

II. Installation

362.10 Uses Permitted. For the purpose of this article, the first floor of a building shall be that floor that has 50 percent or more of the exterior wall surface area level with or above finished grade. One additional level that is the first level and not designed for human habitation and used only for vehicle parking, storage, or similar use shall be permitted. The use of ENT and fittings shall be permitted in the following:

- (1) In any building not exceeding three floors above grade as follows:
 - a. For exposed work, where not prohibited by 362.12
 - b. Concealed within walls, floors, and ceilings
- (2) In any building exceeding three floors above grade, ENT shall be concealed within walls, floors, and ceilings where the walls, floors, and ceilings provide a thermal barrier of material that has at least a 15-minute finish rating as identified in listings of fire-rated assemblies. The 15-minute-finish-rated thermal barrier shall be permitted to be used for combustible or noncombustible walls, floors, and ceilings.

Exception to (2): Where a fire sprinkler system(s) is installed in accordance with NFPA 13-2002, Standard for the Installation of Sprinkler Systems, on all floors, ENT shall be permitted to be used within walls, floors, and ceilings, exposed or concealed, in buildings exceeding three floors above grade.

FPN: A finish rating is established for assemblies containing combustible (wood) supports. The finish rating is defined as the time at which the wood stud or wood joist reaches an average temperature rise of 121°C (250°F) or an individual temperature of 163°C (325°F) as measured on the plane of the wood nearest the fire. A finish rating is not intended to represent a rating for a membrane ceiling.

- (4) In concealed, dry, and damp locations not prohibited by 362.12.
- (5) Above suspended ceilings where the suspended ceilings provide a thermal barrier of material that has at least a 15-minute finish rating as identified in listings of fire-rated assemblies, except as permitted in 362.10(1)(a).

Exception to (5): ENT shall be permitted to be used above suspended ceilings in buildings exceeding three floors above grade where the building is protected throughout by a fire sprinkler system installed in accordance with NFPA 13-2002, Standard for the Installation of Sprinkler Systems.

- (6) Encased in poured concrete, or embedded in a concrete slab on grade where ENT is placed on sand or approved screenings, provided fittings identified for this purpose are used for connections.
- (7) For wet locations indoors as permitted in this section or in a concrete slab on or below grade, with fittings listed for the purpose.

FPN: Extreme cold may cause some types of nonmetallic conduits to become brittle and therefore more susceptible to damage from physical contact.

362.12 Uses Not Permitted. ENT shall not be used in the following:

- (2) For the support of luminaires (fixtures) and other equipment
- (3) Where subject to ambient temperatures in excess of 50°C (122°F) unless listed otherwise
- (4) For conductors or cables operating at a temperature higher than the ENT listed temperature rating

Exception to (4): Conductors or cables rated at a temperature higher than the ENT listed temperature rating shall be permitted to be installed in ENT, provided they are not operated at a temperature higher than the ENT listed temperature rating.

- (5) For direct earth burial
- (7) In exposed locations, except as permitted by 362.10(1), 362.10(5), and 362.10(7)
- (9) Where exposed to the direct rays of the sun, unless identified as sunlight resistant
- (10) Where subject to physical damage

362.20 Size.

(A) Minimum. ENT smaller than metric designator 16 (trade size ½) shall not be used.

(B) Maximum. ENT larger than metric designator 53 (trade size 2) shall not be used.

FPN: See 300.1(C) for the metric designators and trade sizes. These are for identification purposes only and do not relate to actual dimensions.

362.22 Number of Conductors. The number of conductors shall not exceed that permitted by the percentage fill in Table 1, Chapter 9.

Cables shall be permitted to be installed where such use is not prohibited by the respective cable articles. The number of cables shall not exceed the allowable percentage fill specified in Table 1, Chapter 9.

362.24 Bends — How Made. Bends shall be so made that the tubing will not be damaged and the internal diameter of the tubing will not be effectively reduced. Bends shall be permitted to be made manually without auxiliary equipment, and the radius of the curve to the centerline of such bends shall not be less than shown in Table 2, Chapter 9 using the column “Other Bends.”

362.26 Bends — Number in One Run. There shall not be more than the equivalent of four quarter bends (360 degrees total) between pull points, for example, conduit bodies and boxes.

362.28 Trimming. All cut ends shall be trimmed inside and outside to remove rough edges.

362.30 Securing and Supporting. ENT shall be installed as a complete system in accordance with 300.18 and shall be securely fastened in place and supported in accordance with 362.30(A) and (B).

(A) Securely Fastened. ENT shall be securely fastened at intervals not exceeding 900 mm (3 ft). In addition, ENT shall be securely fastened in place within 900 mm (3 ft) of each outlet box, device box, junction box, cabinet, or fitting where it terminates.

Exception No. 1: Lengths not exceeding a distance of 1.8 m (6 ft) from a luminaire (fixture) terminal connection for tap connections to lighting luminaires (fixtures) shall be permitted without being secured.

Exception No. 2: Lengths not exceeding 1.8 m (6 ft) from the last point where the raceway is securely fastened for connections within an accessible ceiling to luminaire(s) [lighting fixture(s)] or other equipment.

(B) Supports. Horizontal runs of ENT supported by openings in framing members at intervals not exceeding 900 mm (3 ft) and securely fastened within 900 mm (3 ft) of termination points shall be permitted.

362.46 Bushings. Where a tubing enters a box, fitting, or other enclosure, a bushing or adapter shall be provided to protect the wire from abrasion unless the box, fitting, or enclosure design provides equivalent protection.

FPN: See 300.4(F) for the protection of conductors size 4 AWG or larger.

362.48 Joints. All joints between lengths of tubing and between tubing and couplings, fittings, and boxes shall be by an approved method.

362.56 Splices and Taps. Splices and taps shall be made only in accordance with 300.15.

FPN: See Article 314 for rules on the installation and use of boxes and conduit bodies.

362.60 Grounding. Where equipment grounding is required, a separate equipment grounding conductor shall be installed in the raceway.

ARTICLE 380 Multioutlet Assembly

380.1 Scope. This article covers the use and installation requirements for multioutlet assemblies.

380.2 Use.

(A) Permitted. The use of a multioutlet assembly shall be permitted in dry locations.

(B) Not Permitted. A multioutlet assembly shall not be installed as follows:

- (1) Where concealed, except that it shall be permissible to surround the back and sides of a metal multioutlet assembly by the building finish or recess a nonmetallic multioutlet assembly in a baseboard
- (2) Where subject to severe physical damage

380.3 Metal Multioutlet Assembly Through Dry Partitions. It shall be permissible to extend a metal multioutlet assembly through (not run within) dry partitions if arrangements are made for removing the cap or cover on all exposed portions and no outlet is located within the partitions.

Chapter 4 Equipment for General Use

ARTICLE 400 Flexible Cords and Cables

I. General

400.1 Scope. This article covers general requirements, applications, and construction specifications for flexible cords and flexible cables.

400.2 Other Articles. Flexible cords and flexible cables shall comply with this article and with the applicable provisions of other articles of this *Code*.

400.3 Suitability. Flexible cords and cables and their associated fittings shall be suitable for the conditions of use and location.

400.7 Uses Permitted.

(A) Uses. Flexible cords and cables shall be used only for the following:

- (1) Pendants
- (2) Wiring of luminaires (fixtures)
- (3) Connection of portable lamps, portable and mobile signs, or appliances
- (6) Connection of utilization equipment to facilitate frequent interchange
- (7) Prevention of the transmission of noise or vibration
- (8) Appliances where the fastening means and mechanical connections are specifically designed to permit ready removal for maintenance and repair, and the appliance is intended or identified for flexible cord connection
- (9) Connection of moving parts
- (10) Where specifically permitted elsewhere in this *Code* or the *NEC*.

(B) Attachment Plugs. Where used as permitted in 400.7(A)(3), (A)(6), and (A)(8), each flexible cord shall be equipped with an attachment plug and shall be energized from a receptacle outlet.

400.8 Uses Not Permitted. Unless specifically permitted in 400.7, flexible cords and cables shall not be used for the following:

- (1) As a substitute for the fixed wiring of a structure
- (2) Where run through holes in walls, structural ceilings, suspended ceilings, dropped ceilings, or floors

- (3) Where run through doorways, windows, or similar openings
- (4) Where attached to building surfaces
- (5) Where concealed by walls, floors, or ceilings or located above suspended or dropped ceilings
- (6) Where installed in raceways, except as otherwise permitted in this *Code* or the *NEC*
- (7) Where subject to physical damage

400.9 Splices. Flexible cord shall be used only in continuous lengths without splice or tap where initially installed in applications permitted by 400.7(A). The repair of hard-service cord and junior hard-service cord (see Trade Name column in Table 400.4 in the *NEC*) 14 AWG and larger shall be permitted if conductors are spliced in accordance with 110.14(B) and the completed splice retains the insulation, outer sheath properties, and usage characteristics of the cord being spliced.

400.10 Pull at Joints and Terminals. Flexible cords and cables shall be connected to devices and to fittings so that tension is not transmitted to joints or terminals.

FPN: Some methods of preventing pull on a cord from being transmitted to joints or terminals are knotting the cord, winding with tape, and fittings designed for the purpose.

ARTICLE 404 Switches

I. Installation

404.1 Scope. The provisions of this article shall apply to all switches, switching devices, and circuit breakers where used as switches.

404.2 Switch Connections.

(A) Three-Way and Four-Way Switches. Three-way and four-way switches shall be wired so that all switching is done only in the ungrounded circuit conductor. Where in metal raceways or metal-armored cables, wiring between switches and outlets shall be in accordance with 300.20(A).

Exception: Switch loops shall not require a grounded conductor.

(B) Grounded Conductors. Switches or circuit breakers shall not disconnect the grounded conductor of a circuit.

Exception: A switch or circuit breaker shall be permitted to disconnect a grounded circuit conductor where all circuit conductors are disconnected simultaneously, or where the device is arranged so that the grounded conductor cannot be disconnected until all the ungrounded conductors of the circuit have been disconnected.

404.3 Enclosure.

(A) General. Switches and circuit breakers shall be of the externally operable type mounted in an enclosure listed for the intended use. The minimum wire-bending space at terminals and minimum gutter space provided in switch enclosures shall be as required in 312.6.

Exception No. 1: Pendant- and surface-type snap switches and knife switches mounted on an open-face switchboard or panelboard shall be permitted without enclosures.

(B) Used as a Raceway. Enclosures shall not be used as junction boxes, auxiliary gutters, or raceways for conductors feeding through or tapping off to other switches or overcurrent devices, unless the enclosure complies with 312.8.

404.4 Wet Locations. A switch or circuit breaker in a wet location or outside of a building shall be enclosed in a weatherproof enclosure or cabinet that shall comply with 312.2(A). Switches shall not be installed within wet locations in tub or shower spaces unless installed as part of a listed tub or shower assembly.

404.5 Time Switches, Flashers, and Similar Devices. Time switches, flashers, and similar devices shall be of the enclosed type or shall be mounted in cabinets or boxes or equipment enclosures. Energized parts shall be barriered to prevent operator exposure when making manual adjustments or switching.

404.8 Accessibility and Grouping.

(A) Location. All switches and circuit breakers used as switches shall be located so that they may be operated from a readily accessible place. They shall be installed such that the center of the grip of the operating handle of the switch or circuit breaker, when in its highest position, is not more than 2.0 m (6 ft 7 in.) above the floor or working platform.

Exception No. 2: Switches and circuit breakers installed adjacent to motors, appliances, or other equipment that they supply shall be permitted to be located higher than 2.0 m (6 ft 7 in.) and to be accessible by portable means.

Exception No. 3: Hookstick operable isolating switches shall be permitted at greater heights.

404.9 Provisions for General-Use Snap Switches.

(A) Faceplates. Faceplates provided for snap switches mounted in boxes and other enclosures shall be installed so

as to completely cover the opening and, where the switch is flush mounted, seat against the finished surface.

(B) Grounding. Snap switches, including dimmer and similar control switches, shall be effectively grounded and shall provide a means to ground metal faceplates, whether or not a metal faceplate is installed. Snap switches shall be considered effectively grounded if either of the following conditions is met:

- (1) The switch is mounted with metal screws to a metal box or to a nonmetallic box with integral means for grounding devices.
- (2) An equipment grounding conductor or equipment bonding jumper is connected to an equipment grounding termination of the snap switch.

Exception to (B): Where no grounding means exists within the snap-switch enclosure or where the wiring method does not include or provide an equipment ground, a snap switch without a grounding connection shall be permitted for replacement purposes only. A snap switch wired under the provisions of this exception and located within reach of earth, grade, conducting floors, or other conducting surfaces shall be provided with a faceplate of nonconducting, noncombustible material or shall be protected by a ground-fault circuit interrupter.

(C) Construction. Metal faceplates shall be of ferrous metal not less than 0.76 mm (0.030 in.) in thickness or of nonferrous metal not less than 1.02 mm (0.040 in.) in thickness. Faceplates of insulating material shall be noncombustible and not less than 2.54 mm (0.010 in.) in thickness, but they shall be permitted to be less than 2.54 mm (0.010 in.) in thickness if formed or reinforced to provide adequate mechanical strength.

404.10 Mounting of Snap Switches.

(A) Surface-Type. Snap switches used with open wiring on insulators shall be mounted on insulating material that separates the conductors at least 13 mm (½ in.) from the surface wired over.

(B) Box Mounted. Flush-type snap switches mounted in boxes that are set back of the finished surface as permitted in 314.20 shall be installed so that the extension plaster ears are seated against the surface. Flush-type snap switches mounted in boxes that are flush with the finished surface or project from it shall be installed so that the mounting yoke or strap of the switch is seated against the box.

404.11 Circuit Breakers as Switches. A hand-operable circuit breaker equipped with a lever or handle, or a power-operated circuit breaker capable of being opened by hand

in the event of a power failure, shall be permitted to serve as a switch if it has the required number of poles.

FPN: See the provisions contained in 240.81 and 240.83 in the *NEC*.

404.12 Grounding of Enclosures. Metal enclosures for switches or circuit breakers shall be grounded as specified in Article 250. Where nonmetallic enclosures are used with metal raceways or metal-armored cables, provision shall be made for grounding continuity.

Except as covered in 404.9(B), Exception, nonmetallic boxes for switches shall be installed with a wiring method that provides or includes an equipment ground.

404.14 Rating and Use of Snap Switches. Snap switches shall be used within their ratings and as indicated in 404.14(A), (B), (C), and (E).

FPN No. 2: For switches controlling motors, see 430.83, 430.109, and 430.110 in the *NEC*.

(A) Alternating Current General-Use Snap Switch. A form of general-use snap switch suitable only for use on ac circuits for controlling the following:

- (1) Resistive and inductive loads, including electric-discharge lamps, not exceeding the ampere rating of the switch at the voltage involved
- (2) Tungsten-filament lamp loads not exceeding the ampere rating of the switch at 120 volts
- (3) Motor loads not exceeding 80 percent of the ampere rating of the switch at its rated voltage

(B) Alternating-Current or Direct-Current General-Use Snap Switch. A form of general-use snap switch suitable for use on either ac or dc circuits for controlling the following:

- (1) Resistive loads not exceeding the ampere rating of the switch at the voltage applied.
- (2) Inductive loads not exceeding 50 percent of the ampere rating of the switch at the applied voltage. Switches rated in horsepower are suitable for controlling motor loads within their rating at the voltage applied.
- (3) Tungsten-filament lamp loads not exceeding the ampere rating of the switch at the applied voltage if T-rated.

(C) CO/ALR Snap Switches. Snap switches rated 20 amperes or less directly connected to aluminum conductors shall be listed and marked CO/ALR.

(E) Dimmer Switches. General-use dimmer switches shall be used only to control permanently installed incandescent luminaires (lighting fixtures) unless listed for the control of other loads and installed accordingly.

ARTICLE 406 Receptacles, Cord Connectors, and Attachment Plugs (Caps)

406.1 Scope. This article covers the rating, type, and installation of receptacles, cord connectors, and attachment plugs (cord caps).

406.2 Receptacle Rating and Type.

(A) Receptacles. Receptacles shall be listed and marked with the manufacturer's name or identification and voltage and ampere ratings.

(B) Rating. Receptacles and cord connectors shall be rated not less than 15 amperes, 125 volts, or 15 amperes, 250 volts, and shall be of a type not suitable for use as lampholders.

FPN: See 210.21(B) for receptacle ratings where installed on branch circuits.

(C) Receptacles for Aluminum Conductors. Receptacles rated 20 amperes or less and designed for the direct connection of aluminum conductors shall be marked CO/ALR.

406.3 General Installation Requirements. Receptacle outlets shall be located in branch circuits in accordance with Part III of Article 210. General installation requirements shall be in accordance with 406.3(A) through 406.3(F).

(A) Grounding Type. Receptacles installed on 15- and 20-ampere branch circuits shall be of the grounding type. Grounding-type receptacles shall be installed only on circuits of the voltage class and current for which they are rated, except as provided in Table 210.21(B)(2) and Table 210.21(B)(3).

Exception: Nongrounding-type receptacles installed in accordance with 406.3(D).

(B) To Be Grounded. Receptacles and cord connectors that have grounding contacts shall have those contacts effectively grounded.

Exception No. 2: Replacement receptacles as permitted by 406.3(D).

(C) Methods of Grounding. The grounding contacts of receptacles and cord connectors shall be grounded by connection to the equipment grounding conductor of the circuit supplying the receptacle or cord connector.

The branch-circuit wiring method shall include or provide an equipment-grounding conductor to which the grounding contacts of the receptacle or cord connector are connected.

FPN No. 1: See 250.118 for acceptable grounding means.

FPN No. 2: For extensions of existing branch circuits, see 250.130.

(D) Replacements. Replacement of receptacles shall comply with 406.3(D)(1), (D)(2), and (D)(3) as applicable.

(1) Grounding-Type Receptacles. Where a grounding means exists in the receptacle enclosure or a grounding conductor is installed in accordance with 250.130(C), grounding-type receptacles shall be used and shall be connected to the grounding conductor in accordance with 406.3(C) or 250.130(C).

(2) Ground-Fault Circuit Interrupters. Ground-fault circuit-interrupter protected receptacles shall be provided where replacements are made at receptacle outlets that are required to be so protected elsewhere in this *Code*.

(3) Non-grounding-Type Receptacles. Where grounding means does not exist in the receptacle enclosure, the installation shall comply with (D)(3)(a), (D)(3)(b), or (D)(3)(c).

(a) A non-grounding-type receptacle(s) shall be permitted to be replaced with another non-grounding-type receptacle(s).

(b) A non-grounding-type receptacle(s) shall be permitted to be replaced with a ground-fault circuit interrupter-type of receptacle(s). These receptacles shall be marked “No Equipment Ground.” An equipment grounding conductor shall not be connected from the ground-fault circuit-interrupter-type receptacle to any outlet supplied from the ground-fault circuit-interrupter receptacle.

(c) A non-grounding-type receptacle(s) shall be permitted to be replaced with a grounding-type receptacle(s) where supplied through a ground-fault circuit interrupter. Grounding-type receptacles supplied through the ground-fault circuit interrupter shall be marked “GFCI Protected” and “No Equipment Ground.” An equipment grounding conductor shall not be connected between the grounding-type receptacles.

(E) Cord-and-Plug-Connected Equipment. The installation of grounding-type receptacles shall not be used as a requirement that all cord-and-plug-connected equipment be of the grounded type.

FPN: See 250.114 for types of cord-and-plug-connected equipment to be grounded.

(F) Noninterchangeable Types. Receptacles connected to circuits that have different voltages, frequencies, or types of current (ac or dc) on the same premises shall be of such design that the attachment plugs used on these circuits are not interchangeable.

406.4 Receptacle Mounting. Receptacles shall be mounted in boxes or assemblies designed for the purpose, and such boxes or assemblies shall be securely fastened in place unless otherwise permitted elsewhere in this *Code*.

(A) Boxes That Are Set Back. Receptacles mounted in boxes that are set back from the finished surface as permitted in 314.20 shall be installed such that the mounting yoke or strap of the receptacle is held rigidly at the finished surface.

(B) Boxes That Are Flush. Receptacles mounted in boxes that are flush with the finished surface or project therefrom shall be installed such that the mounting yoke or strap of the receptacle is held rigidly against the box or box cover.

(C) Receptacles Mounted on Covers. Receptacles mounted to and supported by a cover shall be held rigidly against the cover by more than one screw or shall be a device assembly or box cover listed and identified for securing by a single screw.

(D) Position of Receptacle Faces. After installation, receptacle faces shall be flush with or project from faceplates of insulating material and shall project a minimum of 0.4 mm (0.015 in.) from metal faceplates.

Exception No. 1: Listed kits or assemblies encompassing receptacles and nonmetallic faceplates that cover the receptacle face, where the plate cannot be installed on any other receptacle, shall be permitted.

Exception No. 2: Listed nonmetallic faceplates that cover the receptacle face to a maximum thickness of 1 mm (0.040 in.) shall be permitted.

(E) Receptacles in Countertops and Similar Work Surfaces in Dwelling Units. Receptacles shall not be installed in a face-up position in countertops or similar work surfaces.

(F) Exposed Terminals. Receptacles shall be enclosed so that live wiring terminals are not exposed to contact.

406.5 Receptacle Faceplates (Cover Plates). Receptacle faceplates shall be installed so as to completely cover the opening and seat against the mounting surface.

(A) Thickness of Metal Faceplates. Metal faceplates shall be of ferrous metal not less than 0.76 mm (0.030 in.) in thickness or of nonferrous metal not less than 1.02 mm (0.040 in.) in thickness.

(B) Grounding. Metal faceplates shall be grounded.

(C) Faceplates of Insulating Material. Faceplates of insulating material shall be noncombustible and not less than 2.54 mm (0.10 in.) in thickness but shall be permitted to be less than 2.54 mm (0.10 in.) in thickness if formed or reinforced to provide adequate mechanical strength.

406.6 Attachment Plugs, Cord Connectors, and Flanged Surface Devices. All attachment plugs, cord connectors, and flanged surface devices (inlets and outlets) shall be listed and marked with the manufacturer's name or identification and voltage and ampere ratings.

(B) Connection of Attachment Plugs. Attachment plugs shall be installed so that their prongs, blades, or pins are not energized unless inserted into an energized receptacle. No receptacle shall be installed so as to require the insertion of an energized attachment plug as its source of supply.

406.8 Receptacles in Damp or Wet Locations.

(A) Damp Locations. A receptacle installed outdoors in a location protected from the weather or in other damp locations shall have an enclosure for the receptacle that is weatherproof when the receptacle is covered (attachment plug cap not inserted and receptacle covers closed).

An installation suitable for wet locations shall also be considered suitable for damp locations.

A receptacle shall be considered to be in a location protected from the weather where located under roofed open porches, canopies, marquees, and the like, and will not be subjected to a beating rain or water runoff.

(B) Wet Locations.

(1) 15- and 20-Ampere Receptacles in a Wet Location. 15- and 20-ampere, 125- and 250-volt receptacles installed in a wet location shall have an enclosure that is weatherproof whether or not the attachment plug cap is inserted.

(2) Other Receptacles. All other receptacles installed in a wet location shall comply with (B)(2)(a) or (B)(2)(b).

(a) A receptacle installed in a wet location, where the product intended to be plugged into it is not attended while in use, shall have an enclosure that is weatherproof with the attachment plug cap inserted or removed.

(b) A receptacle installed in a wet location where the product intended to be plugged into it will be attended while in use (e.g., portable tools) shall have an enclosure that is weatherproof when the attachment plug is removed.

(C) Bathtub and Shower Space. Receptacles shall not be installed within or directly over a bathtub or shower stall.

(E) Flush Mounting with Faceplate. The enclosure for a receptacle installed in an outlet box flush-mounted in a finished surface shall be made weatherproof by means of a weatherproof faceplate assembly that provides a watertight connection between the plate and the finished surface.

406.9 Grounding-Type Receptacles, Adapters, Cord Connectors, and Attachment Plugs.

(C) Grounding Terminal Use. A grounding terminal or grounding-type device shall not be used for purposes other than grounding.

ARTICLE 408
Switchboards and Panelboards

I. General

408.1 Scope. This article covers the following:

- (1) All switchboards, panelboards, and distribution boards installed for the control of light and power circuits
- (2) Battery-charging panels supplied from light or power circuits

408.2 Other Articles. Switches, circuit breakers, and over-current devices used on switchboards, panelboards, and distribution boards, and their enclosures shall comply with this article and also with the requirements of Articles 240, 250, 312, 314, 404, and other articles that apply.

408.3 Support and Arrangement of Busbars and Conductors.

(C) Used as Service Equipment. Each switchboard or panelboard, if used as service equipment, shall be provided with a main bonding jumper sized in accordance with 250.28(D) or the equivalent placed within the panelboard or one of the sections of the switchboard for connecting the grounded service conductor on its supply side to the switchboard or panelboard frame. All sections of a switchboard shall be bonded together using an equipment bonding conductor sized in accordance with Table 250.122 or Table 250.66 as appropriate.

408.4 Circuit Directory or Circuit Identification. Every circuit and circuit modification shall be legibly identified as to its clear, evident, and specific purpose or use. The identification shall include sufficient detail to allow each circuit to be distinguished from all others. The identification shall be included in a circuit directory that is located on the face or inside of the panel door in the case of a panelboard, and located at each switch on a switchboard.

408.7 Unused Openings. Unused openings for circuit breakers and switches shall be closed using identified closures, or other approved means that provide protection substantially equivalent to the wall of the enclosure.

III. Panelboards

408.30 General. All panelboards shall have a rating not less than the minimum feeder capacity required for the load calculated in accordance with Article 220. Panelboards shall be durably marked by the manufacturer with the voltage and the current rating and the number of phases for which they are designed and with the manufacturer's name or trademark in such a manner so as to be visible after installation, without disturbing the interior parts or wiring.

FPN: See 110.22 for additional requirements.

408.34 Classification of Panelboards. Panelboards shall be classified for the purposes of this article as either lighting and appliance branch-circuit panelboards or power panelboards, based on their content. A lighting and appliance branch circuit is a branch circuit that has a connection to the neutral of the panelboard and that has overcurrent protection of 30 amperes or less in one or more conductors.

(A) Lighting and Appliance Branch-Circuit Panelboard. A lighting and appliance branch-circuit panelboard is one having more than 10 percent of its overcurrent devices protecting lighting and appliance branch circuits.

(B) Power Panelboard. A power panelboard is one having 10 percent or fewer of its overcurrent devices protecting lighting and appliance branch circuits.

408.35 Number of Overcurrent Devices on One Panelboard. Not more than 42 overcurrent devices (other than those provided for in the mains) of a lighting and appliance branch-circuit panelboard shall be installed in any one cabinet or cutout box.

A lighting and appliance branch-circuit panelboard shall be provided with physical means to prevent the installation of more overcurrent devices than that number for which the panelboard was designed, rated, and approved.

For the purposes of this article, a 2-pole circuit breaker shall be considered two overcurrent devices; a 3-pole circuit breaker shall be considered three overcurrent devices.

408.36 Overcurrent Protection.

(A) Lighting and Appliance Branch-Circuit Panelboard Individually Protected. Each lighting and appliance branch-circuit panelboard shall be individually protected on the supply side by not more than two main circuit breakers or two sets of fuses having a combined rating not greater than that of the panelboard.

Exception No. 1: Individual protection for a lighting and appliance panelboard shall not be required if the panelboard feeder has overcurrent protection not greater than the rating of the panelboard.

Exception No. 2: For existing installations, individual protection for lighting and appliance branch-circuit panelboards shall not be required where such panelboards are used as service equipment in supplying an individual residential occupancy.

(B) Power Panelboard Protection. In addition to the requirements of 408.30, a power panelboard with supply conductors that include a neutral, and having more than 10 percent of its overcurrent devices protecting branch circuits rated 30 amperes or less, shall be protected by an overcurrent protective device having a rating not greater than that of the panelboard. This overcurrent protective device shall be located within or at any point on the supply side of the panelboard.

Exception: This individual protection shall not be required for a power panelboard used as service equipment with multiple disconnecting means in accordance with 230.71.

(C) Snap Switches Rated at 30 Amperes or Less. Panelboards equipped with snap switches rated at 30 amperes or less shall have overcurrent protection of 200 amperes or less.

(F) Back-Fed Devices. Plug-in-type overcurrent protection devices or plug-in type main lug assemblies that are backfed and used to terminate field-installed ungrounded supply conductors shall be secured in place by an additional fastener that requires other than a pull to release the device from the mounting means on the panel.

408.37 Panelboards in Damp or Wet Locations. Panelboards in damp or wet locations shall be installed to comply with 312.2(A).

408.38 Enclosure. Panelboards shall be mounted in cabinets, cutout boxes, or enclosures designed for the purpose and shall be dead-front.

408.39 Relative Arrangement of Switches and Fuses. In panelboards, fuses of any type shall be installed on the load side of any switches.

Exception: Fuses installed as part of service equipment in accordance with the provisions of 230.94 shall be permitted on the line side of the service switch.

408.40 Grounding of Panelboards. Panelboard cabinets and panelboard frames, if of metal, shall be in physical contact with each other and shall be grounded. Where the panelboard is used with nonmetallic raceway or cable or where separate grounding conductors are provided, a terminal bar for the grounding conductors shall be secured inside the cabinet. The terminal bar shall be bonded to the cabinet and panelboard frame, if of metal; otherwise it shall be

connected to the grounding conductor that is run with the conductors feeding the panelboard.

Exception: Where an isolated equipment grounding conductor is provided as permitted by 250.146(D) in the NEC, the insulated equipment grounding conductor that is run with the circuit conductors shall be permitted to pass through the panelboard without being connected to the panelboard's equipment grounding terminal bar.

Grounding conductors shall not be connected to a terminal bar provided for grounded conductors (may be a neutral) unless the bar is identified for the purpose and is located where interconnection between equipment grounding conductors and grounded circuit conductors is permitted or required by Article 250.

408.41 Grounded Conductor Terminations. Each grounded conductor shall terminate within the panelboard in an individual terminal that is not also used for another conductor.

Exception: Grounded conductors of circuits with parallel conductors shall be permitted to terminate in a single terminal if the terminal is identified for connection of more than one conductor.

ARTICLE 410
Luminaires (Lighting Fixtures),
Lamp holders, and Lamps

I. General

410.1 Scope. This article covers luminaires (lighting fixtures), lampholders, pendants, incandescent filament lamps, arc lamps, electric-discharge lamps, decorative lighting products, lighting accessories for temporary seasonal and holiday use, portable flexible lighting products, and the wiring and equipment forming part of such products and lighting installations.

410.2 Application of Other Articles. Lighting systems operating at 30 volts or less shall conform to Article 411.

410.3 Live Parts. Luminaires (fixtures), lampholders, and lamps shall have no live parts normally exposed to contact. Exposed accessible terminals in lampholders and switches shall not be installed in metal luminaire (fixture) canopies or in open bases of portable table or floor lamps.

Exception: Cleat-type lampholders located at least 2.5 m (8 ft) above the floor shall be permitted to have exposed terminals.

II. Luminaire (Fixture) Locations

410.4 Luminaires (Fixtures) in Specific Locations.

(A) Wet and Damp Locations. Luminaires (fixtures) installed in wet or damp locations shall be installed so that water cannot enter or accumulate in wiring compartments, lampholders, or other electrical parts. All luminaires (fixtures) installed in wet locations shall be marked, "Suitable for Wet Locations." All luminaires (fixtures) installed in damp locations shall be marked, "Suitable for Wet Locations" or "Suitable for Damp Locations."

(B) Corrosive Locations. Luminaires (fixtures) installed in corrosive locations shall be of a type suitable for such locations.

(D) Bathtub and Shower Areas. No parts of cord-connected luminaires (fixtures), chain-, cable-, or cord-suspended-luminaires (fixtures), lighting track, pendants, or ceiling-suspended (paddle) fans shall be located within a zone measured 900 mm (3 ft) horizontally and 2.5 m (8 ft) vertically from the top of the bathtub rim or shower stall threshold. This zone is all encompassing and includes the zone directly over the tub or shower stall. Luminaires (lighting fixtures) located in this zone shall be listed for damp locations, or listed for wet locations where subject to shower spray.

410.5 Luminaires (Fixtures) Near Combustible Material. Luminaires (fixtures) shall be constructed, installed, or equipped with shades or guards so that combustible material is not subjected to temperatures in excess of 90°C (194°F).

410.6 Luminaires (Fixtures) Over Combustible Material. Lampholders installed over highly combustible material shall be of the unswitched type. Unless an individual switch is provided for each luminaire (fixture), lampholders shall be located at least 2.5 m (8 ft) above the floor or shall be located or guarded so that the lamps cannot be readily removed or damaged.

410.8 Luminaires (Fixtures) in Clothes Closets.

(A) Definition.

Storage Space. The volume bounded by the sides and back closet walls and planes extending from the closet floor vertically to a height of 1.8 m (6 ft) or to the highest clothes-hanging rod and parallel to the walls at a horizontal distance of 600 mm (24 in.) from the sides and back of the closet walls, respectively, and continuing vertically to the closet ceiling parallel to the walls at a horizontal distance of 300 mm (12 in.) or the width of the shelf, whichever is greater; for a closet that permits access to both sides of a hanging rod, this space includes the volume below the highest rod

extending 300 mm (12 in.) on either side of the rod on a plane horizontal to the floor extending the entire length of the rod.

FPN: See Figure 410.8.

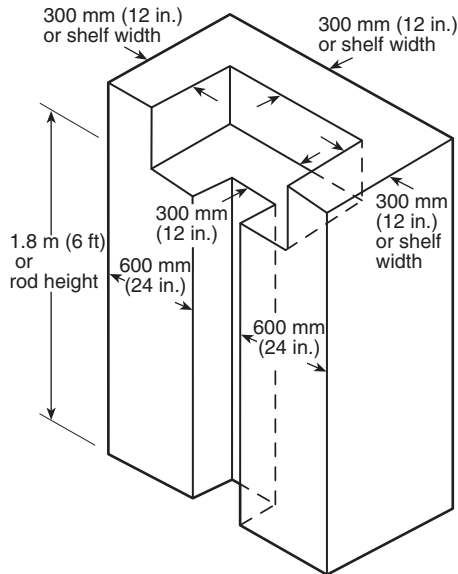

Figure 410.8 Closet Storage Space.

(B) Luminaire (Fixture) Types Permitted. Listed luminaires (fixtures) of the following types shall be permitted to be installed in a closet:

- (1) A surface-mounted or recessed incandescent luminaire (fixture) with a completely enclosed lamp
- (2) A surface-mounted or recessed fluorescent luminaire (fixture)

(C) Luminaire (Fixture) Types Not Permitted. Incandescent luminaires (fixtures) with open or partially enclosed lamps and pendant luminaires (fixtures) or lampholders shall not be permitted.

(D) Location. Luminaires (fixtures) in clothes closets shall be permitted to be installed as follows:

- (1) Surface-mounted incandescent luminaires (fixtures) installed on the wall above the door or on the ceiling, provided there is a minimum clearance of 300 mm (12 in.) between the luminaire (fixture) and the nearest point of a storage space
- (2) Surface-mounted fluorescent luminaires (fixtures) installed on the wall above the door or on the ceiling, provided there is a minimum clearance of 150 mm (6 in.) between the luminaire (fixture) and the nearest point of a storage space
- (3) Recessed incandescent luminaires (fixtures) with a completely enclosed lamp installed in the wall or the ceiling,

provided there is a minimum clearance of 150 mm (6 in.) between the luminaire (fixture) and the nearest point of a storage space

- (4) Recessed fluorescent luminaires (fixtures) installed in the wall or the ceiling, provided there is a minimum clearance of 150 mm (6 in.) between the luminaire (fixture) and the nearest point of a storage space

410.9 Space for Cove Lighting. Coves shall have adequate space and shall be located so that lamps and equipment can be properly installed and maintained.

III. Provisions at Luminaire (Fixture) Outlet Boxes, Canopies, and Pans

410.10 Space for Conductors. Canopies and outlet boxes taken together shall provide adequate space so that luminaire (fixture) conductors and their connecting devices can be properly installed.

410.11 Temperature Limit of Conductors in Outlet Boxes. Luminaires (fixtures) shall be of such construction or installed so that the conductors in outlet boxes shall not be subjected to temperatures greater than that for which the conductors are rated.

Branch-circuit wiring, other than 2-wire or multiwire branch circuits supplying power to luminaires (fixtures) connected together, shall not be passed through an outlet box that is an integral part of a luminaire (fixture) unless the luminaire (fixture) is identified for through-wiring.

FPN: See 410.32 for wiring supplying power to fixtures connected together.

410.12 Outlet Boxes to Be Covered. In a completed installation, each outlet box shall be provided with a cover unless covered by means of a luminaire (fixture) canopy, lampholder, receptacle, or similar device.

410.13 Covering of Combustible Material at Outlet Boxes. Any combustible wall or ceiling finish exposed between the edge of a luminaire (fixture) canopy or pan and an outlet box shall be covered with noncombustible material.

410.14 Connection of Electric-Discharge Luminaires (Lighting Fixtures).

(A) Independent of the Outlet Box. Electric-discharge luminaires (lighting fixtures) supported independently of the outlet box shall be connected to the branch circuit through metal raceway, nonmetallic raceway, Type MC cable, Type AC cable, Type MI cable, nonmetallic sheathed cable, or by flexible cord as permitted in 410.30(B) or 410.30(C).

(B) Access to Boxes. Electric-discharge luminaires (fixtures) surface mounted over concealed outlet, pull, or

junction boxes and designed not to be supported solely by the outlet box shall be provided with suitable openings in the back of the luminaire (fixture) to provide access to the wiring in the box.

IV. Luminaire (Fixture) Supports

410.15 Supports.

(A) General. Luminaires (fixtures) and lampholders shall be securely supported. A luminaire (fixture) that weighs more than 3 kg (6 lb) or exceeds 400 mm (16 in.) in any dimension shall not be supported by the screw shell of a lampholder.

(B) Metal or Nonmetallic Poles Supporting Luminaires (Lighting Fixtures). Metal or nonmetallic poles shall be permitted to be used to support luminaires (lighting fixtures) and as a raceway to enclose supply conductors, provided the following conditions are met:

- (1) A pole shall have a handhole not less than 50 mm × 100 mm (2 in. × 4 in.) with a raintight cover to provide access to the supply terminations within the pole or pole base.

Exception No. 1: No handhole shall be required in a pole 2.5 m (8 ft) or less in height above grade where the supply wiring method continues without splice or pull point, and where the interior of the pole and any splices are accessible by removing the luminaire (fixture).

Exception No. 2: No handhole shall be required in a pole 6.0 m (20 ft) or less in height above grade that is provided with a hinged base.

- (2) Where raceway risers or cable is not installed within the pole, a threaded fitting or nipple shall be brazed, welded, or attached to the pole opposite the handhole for the supply connection.
- (3) A metal pole shall be provided with a grounding terminal as follows:
 - a. A pole with a handhole shall have the grounding terminal accessible from the handhole.
 - b. A pole with a hinged base shall have the grounding terminal accessible within the base.

Exception to (3): No grounding terminal shall be required in a pole 2.5 m (8 ft) or less in height above grade where the supply wiring method continues without splice or pull, and where the interior of the pole and any splices are accessible by removing the luminaire (fixture).

- (4) A metal pole with a hinged base shall have the hinged base and pole bonded together.

- (5) Metal raceways or other equipment grounding conductors shall be bonded to the metal pole with an equipment grounding conductor recognized by 250.118 and sized in accordance with 250.122.
- (6) Conductors in vertical poles used as raceway shall be supported as provided in 300.19 in the *NEC*.

410.16 Means of Support.

(A) Outlet Boxes. Outlet boxes or fittings installed as required by 314.23 and complying with the provisions of 314.27(A) and 314.27(B) shall be permitted to support luminaires (fixtures).

(B) Inspection. Luminaires (fixtures) shall be installed such that the connections between the luminaire (fixture) conductors and the circuit conductors can be inspected without requiring the disconnection of any part of the wiring unless the luminaires (fixtures) are connected by attachment plugs and receptacles.

(C) Suspended Ceilings. Framing members of suspended ceiling systems used to support luminaires (fixtures) shall be securely fastened to each other and shall be securely attached to the building structure at appropriate intervals. Luminaires (fixtures) shall be securely fastened to the ceiling framing member by mechanical means such as bolts, screws, or rivets. Listed clips identified for use with the type of ceiling framing member(s) and luminaire(s) [fixture(s)] shall also be permitted.

(D) Luminaire (Fixture) Studs. Luminaire (fixture) studs that are not a part of outlet boxes, hickeyes, tripods, and crowfeet shall be made of steel, malleable iron, or other material suitable for the application.

(E) Insulating Joints. Insulating joints that are not designed to be mounted with screws or bolts shall have an exterior metal casing, insulated from both screw connections.

(F) Raceway Fittings. Raceway fittings used to support a luminaire(s) [lighting fixture(s)] shall be capable of supporting the weight of the complete fixture assembly and lamp(s).

(H) Trees. Outdoor luminaires (lighting fixtures) and associated equipment shall be permitted to be supported by trees.

FPN No. 1: See 225.26 for restrictions for support of overhead conductors.

FPN No. 2: See 300.5(D) for protection of conductors.

V. Grounding

410.17 General. Luminaires (fixtures) and lighting equipment shall be grounded as required in Article 250 and Part V of this article.

410.18 Exposed Luminaire (Fixture) Parts.

(A) Exposed Conductive Parts. Exposed metal parts shall be grounded or insulated from ground and other conducting surfaces or be inaccessible to unqualified personnel. Lamp tie wires, mounting screws, clips, and decorative bands on glass spaced at least 38 mm (1½ in.) from lamp terminals shall not be required to be grounded.

(B) Made of Insulating Material. Luminaires (fixtures) directly wired or attached to outlets supplied by a wiring method that does not provide a ready means for grounding shall be made of insulating material and shall have no exposed conductive parts.

Exception No. 1: Replacement luminaires (fixtures) shall be permitted to connect an equipment grounding conductor from the outlet in compliance with 250.130(C). The luminaire (fixture) shall then be grounded in accordance with 410.18(A).

Exception No. 2: Where no equipment grounding conductor exists at the outlet, replacement luminaires (fixtures) that are GFCI protected shall not be required to be connected to an equipment grounding conductor.

410.20 Equipment Grounding Conductor Attachment.

Luminaires (fixtures) with exposed metal parts shall be provided with a means for connecting an equipment grounding conductor for such luminaires (fixtures).

410.21 Methods of Grounding.

Luminaires (fixtures) and equipment shall be considered grounded where mechanically connected to an equipment grounding conductor as specified in 250.118 and sized in accordance with 250.122.

VI. Wiring of Luminaires (Fixtures)**410.22 Luminaire (Fixture) Wiring — General.**

Wiring on or within fixtures shall be neatly arranged and shall not be exposed to physical damage. Excess wiring shall be avoided. Conductors shall be arranged so that they are not subjected to temperatures above those for which they are rated.

410.23 Polarization of Luminaires (Fixtures).

Luminaires (fixtures) shall be wired so that the screw shells of lampholders are connected to the same luminaire (fixture) or circuit conductor or terminal. The grounded conductor, where connected to a screw-shell lampholder, shall be connected to the screw shell.

410.28 Protection of Conductors and Insulation.

(A) Properly Secured. Conductors shall be secured in a manner that does not tend to cut or abrade the insulation.

(B) Protection Through Metal. Conductor insulation shall be protected from abrasion where it passes through metal.

(C) Luminaire (Fixture) Stems. Splices and taps shall not be located within luminaire (fixture) arms or stems.

(D) Splices and Taps. No unnecessary splices or taps shall be made within or on a luminaire (fixture).

FPN: For approved means of making connections, see 110.14.

(E) Stranding. Stranded conductors shall be used for wiring on luminaire (fixture) chains and on other movable or flexible parts.

(F) Tension. Conductors shall be arranged so that the weight of the luminaire (fixture) or movable parts does not put tension on the conductors.

410.30 Cord-Connected Lampholders and Luminaires (Fixtures).

(B) Adjustable Luminaires (Fixtures). Luminaires (fixtures) that require adjusting or aiming after installation shall not be required to be equipped with an attachment plug or cord connector, provided the exposed cord is of the hard-usage or extra-hard-usage type and is not longer than that required for maximum adjustment. The cord shall not be subject to strain or physical damage.

(C) Electric-Discharge Luminaires (Fixtures).

(1) Cord Connected Installation. A listed luminaire (fixture) or a listed assembly shall be permitted to be cord connected if the following conditions apply:

- (1) The luminaire (fixture) is located directly below the outlet or busway.
- (2) The flexible cord meets all the following:
 - a. Is visible for its entire length outside the luminaire (fixture)
 - b. Is not subject to strain or physical damage
 - c. Is terminated in a grounding-type attachment plug cap or busway plug, or is a part of a listed assembly incorporating a manufactured wiring system connector in accordance with 604.6(C) in the *NEC*, or has a luminaire (fixture) assembly with a strain relief and canopy

410.31 Luminaires (Fixtures) as Raceways. Luminaires (fixtures) shall not be used as a raceway for circuit conductors unless listed and marked for use as a raceway.

410.32 Wiring Supplying Luminaires (Fixtures) Connected Together. Luminaires (fixtures) designed for end-to-end connection to form a continuous assembly, or luminaires

(fixtures) connected together by recognized wiring methods, shall be permitted to contain the conductors of a 2-wire branch circuit, or one multiwire branch circuit, supplying the connected luminaires (fixtures) and need not be listed as a raceway. One additional 2-wire branch circuit separately supplying one or more of the connected luminaires (fixtures) shall also be permitted.

FPN: See Article 100 for the definition of *Multiwire Branch Circuit*.

410.33 Branch Circuit Conductors and Ballasts. Branch-circuit conductors within 75 mm (3 in.) of a ballast shall have an insulation temperature rating not lower than 90°C (194°F) unless supplying a luminaire (fixture) listed and marked as suitable for a different insulation temperature.

VIII. Installation of Lampholders

410.47 Screw-Shell Type. Lampholders of the screw-shell type shall be installed for use as lampholders only. Where supplied by a circuit having a grounded conductor, the grounded conductor shall be connected to the screw shell.

410.48 Double-Pole Switched Lampholders. Where supplied by the ungrounded conductors of a circuit, the switching device of lampholders of the switched type shall simultaneously disconnect both conductors of the circuit.

410.49 Lampholders in Wet or Damp Locations. Lampholders installed in wet or damp locations shall be of the weatherproof type.

XI. Special Provisions for Flush and Recessed Luminaires (Fixtures)

410.64 General. Luminaires (fixtures) installed in recessed cavities in walls or ceilings shall comply with 410.65 through 410.67.

410.65 Temperature.

(A) Combustible Material. Luminaires (fixtures) shall be installed so that adjacent combustible material will not be subjected to temperatures in excess of 90°C (194°F).

(B) Fire-Resistant Construction. Where a luminaire (fixture) is recessed in fire-resistant material in a building of fire-resistant construction, a temperature higher than 90°C (194°F) but not higher than 150°C (302°F) shall be considered acceptable if the luminaire (fixture) is plainly marked that it is listed for that service.

(C) Recessed Incandescent Luminaires (Fixtures). Incandescent luminaires (fixtures) shall have thermal protection and shall be identified as thermally protected.

Exception No. 1: Thermal protection shall not be required in a recessed luminaire (fixture) identified for use and installed in poured concrete.

Exception No. 2: Thermal protection shall not be required in a recessed luminaire (fixture) whose design, construction, and thermal performance characteristics are equivalent to a thermally protected luminaire (fixture) and are identified as inherently protected.

410.66 Clearance and Installation.

(A) Clearance.

(1) Non-Type IC. A recessed luminaire (fixture) that is not identified for contact with insulation shall have all recessed parts spaced not less than 13 mm (½ in.) from combustible materials. The points of support and the trim finishing off the opening in the ceiling or wall surface shall be permitted to be in contact with combustible materials.

(2) Type IC. A recessed luminaire (fixture) that is identified for contact with insulation, Type IC, shall be permitted to be in contact with combustible materials at recessed parts, points of support, and portions passing through or finishing off the opening in the building structure.

(B) Installation. Thermal insulation shall not be installed above a recessed luminaire (fixture) or with 75 mm (3 in.) of the recessed luminaire's (fixture's) enclosure, wiring compartment, or ballast unless it is identified for contact with insulation, Type IC.

410.67 Wiring.

(A) General. Conductors that have insulation suitable for the temperature encountered shall be used.

(B) Circuit Conductors. Branch-circuit conductors that have an insulation suitable for the temperature encountered shall be permitted to terminate in the luminaire (fixture).

(C) Tap Conductors. Tap conductors of a type suitable for the temperature encountered shall be permitted to run from the luminaire (fixture) terminal connection to an outlet box placed at least 300 mm (1 ft) from the luminaire (fixture). Such tap conductors shall be in suitable raceway or Type AC or MC cable of at least 450 mm (18 in.) but not more than 1.8 m (6 ft) in length.

XIII. Special Provisions for Electric-Discharge Lighting Systems of 1000 Volts or Less

410.73 General.

(A) Open-Circuit Voltage of 1000 Volts or Less. Equipment for use with electric-discharge lighting systems and designed for an open-circuit voltage of 1000 volts or less shall be of a type intended for such service.

(E) Thermal Protection — Fluorescent Luminaires (Fixtures).

(1) Integral Thermal Protection. The ballast of a fluorescent luminaire (fixture) installed indoors shall have integral thermal protection. Replacement ballasts shall also have thermal protection integral with the ballast.

(2) Simple Reactance Ballasts. A simple reactance ballast in a fluorescent luminaire (fixture) with straight tubular lamps shall not be required to be thermally protected.

(F) High-Intensity Discharge Luminaires (Fixtures).

(1) Recessed. Recessed high-intensity luminaires (fixtures) designed to be installed in wall or ceiling cavities shall have thermal protection and be identified as thermally protected.

(2) Inherently Protected. Thermal protection shall not be required in a recessed high-intensity luminaire (fixture) whose design, construction, and thermal performance characteristics are equivalent to a thermally protected luminaire (fixture) and are identified as inherently protected.

(3) Installed in Poured Concrete. Thermal protection shall not be required in a recessed high-intensity discharge luminaire (fixture) identified for use and installed in poured concrete.

(4) Recessed Remote Ballasts. A recessed remote ballast for a high-intensity discharge luminaire (fixture) shall have thermal protection that is integral with the ballast and be identified as thermally protected.

(5) Metal Halide Lamp Containment. Luminaires (fixtures) that use a metal halide lamp other than a thick-glass parabolic reflector lamp (PAR) shall be provided with a containment barrier that encloses the lamp, or shall be provided with a physical means that only allows the use of a lamp that is Type O.

FPN: See ANSI Standard C78.387, *American National Standard for Electric Lamps — Metal Halide Lamps, Methods of Measuring Characteristics*.

410.75 Open-Circuit Voltage Exceeding 300 Volts.

Equipment having an open-circuit voltage exceeding 300 volts shall not be installed in dwelling occupancies unless such equipment is designed so that there will be no exposed live parts when lamps are being inserted, are in place, or are being removed.

410.76 Luminaire (Fixture) Mounting.

(A) Exposed Ballasts. Luminaires (fixtures) that have exposed ballasts or transformers shall be installed so that such ballasts or transformers will not be in contact with combustible material.

(B) Combustible Low-Density Cellulose Fiberboard.

Where a surface-mounted luminaire (fixture) containing a ballast is to be installed on combustible low-density cellulose fiberboard, it shall be listed for this condition or shall be spaced not less than 38 mm (1½ in.) from the surface of the fiberboard. Where such luminaires (fixtures) are partially or wholly recessed, the provisions of 410.64 through 410.67 shall apply.

FPN: Combustible low-density cellulose fiberboard includes sheets, panels, and tiles that have a density of 320 kg/m³ (20 lb/ft³) or less and that are formed of bonded plant fiber material but does not include solid or laminated wood or fiberboard that has a density in excess of 320 kg/m³ (20 lb/ft³) or is a material that has been integrally treated with fire-retarding chemicals to the degree that the flame spread in any plane of the material will not exceed 25, determined in accordance with tests for surface burning characteristics of building materials. See ANSI/ASTM E84-1997, *Test Method for Surface Burning Characteristics of Building Materials*.

XIV. Special Provisions for Electric-Discharge Lighting Systems of More Than 1000 Volts**410.80 General.**

(B) Dwelling Occupancies. Equipment that has an open-circuit voltage exceeding 1000 volts shall not be installed in or on dwelling occupancies.

XV. Lighting Track**410.100 Definition.**

Lighting Track. A manufactured assembly designed to support and energize luminaires (lighting fixtures) that are capable of being readily repositioned on the track. Its length can be altered by the addition or subtraction of sections of track.

410.101 Installation.

(A) Lighting Track. Lighting track shall be permanently installed and permanently connected to a branch circuit. Only lighting track fittings shall be installed on lighting track. Lighting track fittings shall not be equipped with general-purpose receptacles.

(B) Connected Load. The connected load on lighting track shall not exceed the rating of the track. Lighting track shall be supplied by a branch circuit having a rating not more than that of the track.

(C) Locations Not Permitted. Lighting track shall not be installed in the following locations:

- (1) Where likely to be subjected to physical damage
- (2) In wet or damp locations
- (3) Where subject to corrosive vapors

- (4) In storage battery rooms
- (5) In hazardous (classified) locations
- (6) Where concealed
- (7) Where extended through walls or partitions
- (8) Less than 1.5 m (5 ft) above the finished floor except where protected from physical damage or track operating at less than 30 volts rms open-circuit voltage
- (9) Where prohibited by 410.4(D)

(D) Support. Fittings identified for use on lighting track shall be designed specifically for the track on which they are to be installed. They shall be securely fastened to the track, shall maintain polarization and grounding, and shall be designed to be suspended directly from the track.

410.104 Fastening. Lighting track shall be securely mounted so that each fastening is suitable for supporting the maximum weight of luminaires (fixtures) that can be installed. Unless identified for supports at greater intervals, a single section 1.2 m (4 ft) or shorter in length shall have two supports, and, where installed in a continuous row, each individual section of not more than 1.2 m (4 ft) in length shall have one additional support.

410.105 Construction Requirements.

(B) Grounding. Lighting track shall be grounded in accordance with Article 250, and the track sections shall be securely coupled to maintain continuity of the circuitry, polarization, and grounding throughout.

XVI. Decorative Lighting and Similar Accessories

410.110 Listing of Decorative Lighting. Decorative lighting and similar accessories used for holiday lighting and similar purposes, in accordance with 590.3(B), shall be listed.

ARTICLE 411
Lighting Systems Operating at 30 Volts
or Less

411.1 Scope. This article covers lighting systems operating at 30 volts or less and their associated components.

411.2 Definition.

Lighting Systems Operating at 30 Volts or Less. A lighting system consisting of an isolating power supply operating at 30 volts (42.4 volts peak) or less under any load condition, with one or more secondary circuits, each limited to 25

amperes maximum, supplying luminaires (lighting fixtures) and associated equipment identified for the use.

411.3 Listing Required. Lighting systems operating at 30 volts or less shall be listed.

411.4 Locations Not Permitted. Lighting systems operating at 30 volts or less shall not be installed in the locations described in 411.4(A) and 411.4(B).

(A) Where concealed or extended through a building wall unless permitted in (1) or (2):

- (1) Installed using any of the wiring methods specified in Chapter 3
- (2) Installed using wiring supplied by a listed Class 2 power source and installed in accordance with 725.52

(B) Where installed within 3.0 m (10 ft) of pools, spas, fountains, or similar locations, unless permitted by Article 680.

411.5 Secondary Circuits.

(A) Grounding. Secondary circuits shall not be grounded.

(B) Isolation. The secondary circuit shall be insulated from the branch circuit by an isolating transformer.

(C) Bare Conductors. Exposed bare conductors and current-carrying parts shall be permitted for indoor installations only. Bare conductors shall not be installed less than 2.1 m (7 ft) above the finished floor, unless specifically listed for a lower installation height.

411.6 Branch Circuit. Lighting systems operating at 30 volts or less shall be supplied from a maximum 20-ampere branch circuit.

ARTICLE 422
Appliances

I. General

422.1 Scope. This article covers electric appliances used in any occupancy.

422.4 Live Parts. Appliances shall have no live parts normally exposed to contact other than those parts functioning as open-resistance heating elements, such as the heating element of a toaster, which are necessarily exposed.

II. Installation

422.10 Branch-Circuit Rating. This section specifies the ratings of branch circuits capable of carrying appliance current without overheating under the conditions specified.

(A) Individual Circuits. The rating of an individual branch circuit shall not be less than the marked rating of the appliance or the marked rating of an appliance having combined loads as provided in 422.62.

The rating of an individual branch circuit for motor-operated appliances not having a marked rating shall be in accordance with Part II of Article 430 in the *NEC*.

The branch-circuit rating for an appliance that is continuously loaded, other than a motor-operated appliance, shall not be less than 125 percent of the marked rating, or not less than 100 percent of the marked rating if the branch-circuit device and its assembly are listed for continuous loading at 100 percent of its rating.

Branch circuits for household cooking appliances shall be permitted to be in accordance with Table 220.55.

(B) Circuits Supplying Two or More Loads. For branch circuits supplying appliance and other loads, the rating shall be determined in accordance with 210.23.

422.11 Overcurrent Protection. Appliances shall be protected against overcurrent in accordance with 422.11(A), 422.11 (B), 422.11(E), 422.11(F), 422.11(G), and 422.10.

(A) Branch-Circuit Overcurrent Protection. Branch circuits shall be protected in accordance with 240.4.

If a protective device rating is marked on an appliance, the branch-circuit overcurrent device rating shall not exceed the protective device rating marked on the appliance.

(B) Household-Type Appliances with Surface Heating Elements. Household-type appliances with surface heating elements having a maximum demand of more than 60 amperes calculated in accordance with Table 220.55 shall have its power supply subdivided into two or more circuits, each of which shall be provided with overcurrent protection rated at not over 50 amperes.

(E) Single Non-motor-Operated Appliance. If the branch circuit supplies a single non-motor-operated appliance, the rating of overcurrent protection shall:

- (1) Not exceed that marked on the appliance;
- (2) Not exceed 20 amperes if the overcurrent protection rating is not marked and the appliance is rated 13.3 amperes or less; or
- (3) Not exceed 150 percent of the appliance rated current if the overcurrent protection rating is not marked and the appliance is rated over 13.3 amperes. Where 150 percent of the appliance rating does not correspond to

a standard overcurrent device ampere rating, the next higher standard rating shall be permitted.

(F) Electric Heating Appliances Employing Resistance-Type Heating Elements Rated More Than 48 Amperes.

(1) Electric Heating Appliances. Electric heating appliances employing resistance-type heating elements rated more than 48 amperes, other than household appliances with surface heating elements covered by 422.11(B), and commercial-type heating appliances covered by 422.11(D) in the *NEC*, shall have the heating elements subdivided. Each subdivided load shall not exceed 48 amperes and shall be protected at not more than 60 amperes.

These supplementary overcurrent protective devices shall be (1) factory-installed within or on the heater enclosure or provided as a separate assembly by the heater manufacturer; (2) accessible; and (3) suitable for branch-circuit protection.

The main conductors supplying these overcurrent protective devices shall be considered branch-circuit conductors.

(G) Motor-Operated Appliances. Motors of motor-operated appliances shall be provided with overload protection in accordance with Part III of Article 430 in the *NEC*. Hermetic refrigerant motor-compressors in air-conditioning or refrigerating equipment shall be provided with overload protection in accordance with Part VI of Article 440. Where appliance overcurrent protective devices that are separate from the appliance are required, data for selection of these devices shall be marked on the appliance. The minimum marking shall be that specified in 430.7 and 440.4 in the *NEC*.

422.12 Central Heating Equipment. Central heating equipment other than fixed electric space-heating equipment shall be supplied by an individual branch circuit.

Exception No. 1: Auxiliary equipment, such as a pump, valve, humidifier, or electrostatic air cleaner directly associated with the heating equipment, shall be permitted to be connected to the same branch circuit.

Exception No. 2: Permanently connected air-conditioning equipment shall be permitted to be connected to the same branch circuit.

422.13 Storage-Type Water Heaters. A fixed storage-type water heater that has a capacity of 450 L (120 gal) or less shall be considered a continuous load.

FPN: For branch-circuit rating, see 422.10.

422.15 Central Vacuum Outlet Assemblies.

(A) Listed central vacuum outlet assemblies shall be permitted to be connected to a branch circuit in accordance with 210.23(A).

(B) The ampacity of the connecting conductors shall not be less than the ampacity of the branch circuit conductors to which they are connected.

(C) An equipment grounding conductor shall be used where the central vacuum outlet assembly has accessible non-current-carrying metal parts.

422.16 Flexible Cords.

(A) **General.** Flexible cord shall be permitted (1) for the connection of appliances to facilitate their frequent interchange or to prevent the transmission of noise or vibration or (2) to facilitate the removal or disconnection of appliances that are fastened in place, where the fastening means and mechanical connections are specifically designed to permit ready removal for maintenance or repair and the appliance is intended or identified for flexible cord connection.

(B) Specific Appliances.

(1) **Electrically Operated Kitchen Waste Disposers.** Electrically operated kitchen waste disposers shall be permitted to be cord-and-plug connected with a flexible cord identified as suitable for the purpose in the installation instructions of the appliance manufacturer, where all of the following conditions are met.

- (1) The flexible cord shall be terminated with a grounding-type attachment plug.

Exception: A listed kitchen waste disposer distinctly marked to identify it as protected by a system of double insulation, or its equivalent, shall not be required to be terminated with a grounding-type attachment plug.

- (2) The length of the cord shall not be less than 450 mm (18 in.) and not over 900 mm (36 in.).
- (3) Receptacles shall be located to avoid physical damage to the flexible cord.
- (4) The receptacle shall be accessible.

(2) **Built-in Dishwashers and Trash Compactors.** Built-in dishwashers and trash compactors shall be permitted to be cord-and-plug connected with a flexible cord identified as suitable for the purpose in the installation instructions of the appliance manufacturer where all of the following conditions are met.

- (1) The flexible cord shall be terminated with a grounding-type attachment plug.

Exception: A listed dishwasher or trash compactor distinctly marked to identify it as protected by a system of double insulation, or its equivalent, shall not be required to be terminated with a grounding-type attachment plug.

- (2) The length of the cord shall be 0.9 m to 1.2 m (3 ft to 4 ft) measured from the face of the attachment plug to the plane of the rear of the appliance.

- (3) Receptacles shall be located to avoid physical damage to the flexible cord.
- (4) The receptacle shall be located in the space occupied by the appliance or adjacent thereto.
- (5) The receptacle shall be accessible.

(3) **Wall-Mounted Ovens and Counter-Mounted Cooking Units.** Wall-mounted ovens and counter-mounted cooking units complete with provisions for mounting and for making electrical connections shall be permitted to be permanently connected or, only for ease in servicing or for installation, cord-and-plug connected.

A separable connector or a plug and receptacle combination in the supply line to an oven or cooking unit shall be approved for the temperature of the space in which it is located.

(4) **Range Hoods.** Range hoods shall be permitted to be cord-and-plug connected with a flexible cord identified as suitable for use on range hoods in the installation instructions of the appliance manufacturer, where all of the following conditions are met:

- (1) The flexible cord is terminated with a grounding-type attachment plug.

Exception: A listed range hood distinctly marked to identify it as protected by a system of double insulation, or its equivalent, shall not be required to be terminated with a grounding-type attachment plug.

- (2) The length of the cord is not less than 450 mm (18 in.) and not over 900 mm (36 in.).
- (3) Receptacles are located to avoid physical damage to the flexible cord.
- (4) The receptacle is accessible.
- (5) The receptacle is supplied by an individual branch circuit.

422.17 Protection of Combustible Material. Each electrically heated appliance that is intended by size, weight, and service to be located in a fixed position shall be placed so as to provide ample protection between the appliance and adjacent combustible material.

422.18 Support of Ceiling-Suspended (Paddle) Fans. Ceiling-suspended (paddle) fans shall be supported independently of an outlet box or by listed outlet box or outlet box systems identified for the use and installed in accordance with 314.27(D).

422.20 Other Installation Methods. Appliances employing methods of installation other than covered by this article shall be permitted to be used only by special permission.

III. Disconnecting Means

422.30 General. A means shall be provided to disconnect each appliance from all ungrounded conductors in accordance with the following sections of Part III. If an appliance is supplied by more than one source, the disconnecting means shall be grouped and identified.

422.31 Disconnection of Permanently Connected Appliances.

(A) Rated at Not Over 300 Volt-Amperes or 1/8 Horsepower. For permanently connected appliances rated at not over 300 volt-amperes or 1/8 hp, the branch-circuit overcurrent device shall be permitted to serve as the disconnecting means.

(B) Appliances Rated Over 300 Volt-Amperes or 1/8 Horsepower. For permanently connected appliances rated over 300 volt-amperes or 1/8 hp, the branch-circuit switch or circuit breaker shall be permitted to serve as the disconnecting means where the switch or circuit breaker is within sight from the appliance or is capable of being locked in the open position. The provision for locking or adding a lock to the disconnecting means shall be installed on or at the switch or circuit breaker used as the disconnecting means and shall remain in place with or without the lock installed.

FPN: For appliances employing unit switches, see 422.34.

422.32 Disconnecting Means for Motor-Driven Appliance. If a switch or circuit breaker serves as the disconnecting means for a permanently connected motor-driven appliance of more than 1/8 hp, it shall be located within sight from the motor controller and shall comply with Part IX of Article 430 of the *NEC*.

Exception: If a motor-driven appliance of more than 1/8 hp is provided with a unit switch that complies with 422.34(B), (C), or (D), the switch or circuit breaker serving as the other disconnecting means shall be permitted to be out of sight from the motor controller.

422.33 Disconnection of Cord-and-Plug-Connected Appliances.

(A) Separable Connector or an Attachment Plug and Receptacle. For cord-and-plug-connected appliances, an accessible separable connector or an accessible plug and receptacle shall be permitted to serve as the disconnecting means. Where the separable connector or plug and receptacle are not accessible, cord-and-plug-connected appliances shall be provided with disconnecting means in accordance with 422.31.

(B) Connection at the Rear Base of a Range. For cord-and-plug-connected household electric ranges, an attach-

ment plug and receptacle connection at the rear base of a range, if it is accessible from the front by removal of a drawer, shall be considered as meeting the intent of 422.33(A).

(C) Rating. The rating of a receptacle or of a separable connector shall not be less than the rating of any appliance connected thereto.

Exception: Demand factors authorized elsewhere in this Code shall be permitted to be applied to the rating of a receptacle or of a separable connector.

422.34 Unit Switch(es) as Disconnecting Means. A unit switch(es) with a marked-off position that is a part of an appliance and disconnects all ungrounded conductors shall be permitted as the disconnecting means required by this article where other means for disconnection are provided in occupancies specified in 422.34(B) through 422.34(D).

(B) Two-Family Dwellings. In two-family dwellings, the other disconnecting means shall be permitted either inside or outside of the dwelling unit in which the appliance is installed. In this case, an individual switch or circuit breaker for the dwelling unit shall be permitted and shall also be permitted to control lamps and other appliances.

(C) One-Family Dwellings. In one-family dwellings, the service disconnecting means shall be permitted to be the other disconnecting means.

(D) Other Occupancies. In other occupancies, the branch-circuit switch or circuit breaker, where readily accessible for servicing of the appliance, shall be permitted as the other disconnecting means.

422.35 Switch and Circuit Breaker to Be Indicating. Switches and circuit breakers used as disconnecting means shall be of the indicating type.

V. Marking

422.60 Nameplate.

(A) Nameplate Marking. Each electric appliance shall be provided with a nameplate giving the identifying name and the rating in volts and amperes, or in volts and watts. If the appliance is to be used on a specific frequency or frequencies, it shall be so marked.

Where motor overload protection external to the appliance is required, the appliance shall be so marked.

FPN: See 422.11 for overcurrent protection requirements.

(B) To Be Visible. Marking shall be located so as to be visible or easily accessible after installation.

422.61 Marking of Heating Elements. All heating elements that are rated over one ampere, replaceable in the field, and a part of an appliance shall be legibly marked with the ratings in volts and amperes, or in volts and watts, or with the manufacturer's part number.

422.62 Appliances Consisting of Motors and Other Loads.

(A) Nameplate Horsepower Markings. Where a motor-operated appliance nameplate includes a horsepower rating, that rating shall not be less than the horsepower rating on the motor nameplate. Where an appliance consists of multiple motors, or one or more motors and other loads, the nameplate value shall not be less than the equivalent horsepower of the combined loads, calculated in accordance with 430.110(C)(1) in the *NEC*.

(B) Additional Nameplate Markings. Appliances, other than those factory-equipped with cords and attachment plugs and with nameplates in compliance with 422.60, shall be marked in accordance with 422.62(B)(1) or (B)(2).

(1) Marking. In addition to the marking required in 422.60, the marking on an appliance consisting of a motor with other load(s) or motors with or without other load(s) shall specify the minimum supply circuit conductor ampacity and the maximum rating of the circuit overcurrent protective device. This requirement shall not apply to an appliance with a nameplate in compliance with 422.60 where both the minimum supply circuit conductor ampacity and maximum rating of the circuit overcurrent protective device are not more than 15 amperes.

(2) Alternate Marking Method. An alternative marking method shall be permitted to specify the rating of the largest motor in volts and amperes, and the additional load(s) in volts and amperes, or volts and watts in addition to the marking required in 422.60. The ampere rating of a motor $\frac{1}{8}$ horsepower or less or a nonmotor load 1 ampere or less shall be permitted to be omitted unless such loads constitute the principal load.

ARTICLE 424
Fixed Electric Space-Heating Equipment

I. General

424.1 Scope. This article covers fixed electric equipment used for space heating. For the purpose of this article, heating equipment shall include heating cable, unit heaters, boilers, central systems, or other approved fixed electric space-heat-

ing equipment. This article shall not apply to process heating and room air conditioning.

424.2 Other Articles. Fixed electric space-heating equipment incorporating a hermetic refrigerant motor-compressor shall also comply with Article 440.

424.3 Branch Circuits.

(A) Branch-Circuit Requirements. Individual branch circuits shall be permitted to supply any size fixed electric space-heating equipment.

Branch circuits supplying two or more outlets for fixed electric space-heating equipment shall be rated 15, 20, 25, or 30 amperes. In nondwelling occupancies, fixed infrared heating equipment shall be permitted to be supplied from branch circuits rated not over 50 amperes.

(B) Branch-Circuit Sizing. Fixed electric space heating equipment shall be considered continuous load.

424.6 Listed Equipment. Electric baseboard heaters, heating cables, duct heaters, and radiant heating systems shall be listed and labeled.

II. Installation

424.9 General. All fixed electric space-heating equipment shall be installed in an approved manner.

Permanently installed electric baseboard heaters equipped with factory-installed receptacle outlets, or outlets provided as a separate listed assembly, shall be permitted in lieu of a receptacle outlet(s) that is required by 210.50(B). Such receptacle outlets shall not be connected to the heater circuits.

FPN: Listed baseboard heaters include instructions that may not permit their installation below receptacle outlets.

424.10 Special Permission. Fixed electric space-heating equipment and systems installed by methods other than covered by this article shall be permitted only by special permission.

424.11 Supply Conductors. Fixed electric space-heating equipment requiring supply conductors with over 60°C insulation shall be clearly and permanently marked. This marking shall be plainly visible after installation and shall be permitted to be adjacent to the field connection box.

424.12 Locations.

(A) Exposed to Physical Damage. Where subject to physical damage, fixed electric space-heating equipment shall be protected in an approved manner.

(B) Damp or Wet Locations. Heaters and related equipment installed in damp or wet locations shall be listed for such locations and shall be constructed and installed so that water or other liquids cannot enter or accumulate in or on wired sections, electrical components, or ductwork.

FPN No. 1: See 110.11 for equipment exposed to deteriorating agents.

FPN No. 2: See 680.27(C) for pool deck areas.

424.13 Spacing from Combustible Materials. Fixed electric space-heating equipment shall be installed to provide the required spacing between the equipment and adjacent combustible material, unless it is listed to be installed in direct contact with combustible material.

III. Control and Protection of Fixed Electric Space-Heating Equipment

424.19 Disconnecting Means. Means shall be provided to disconnect the heater, motor controller(s), and supplementary overcurrent protective device(s) of all fixed electric space-heating equipment from all ungrounded conductors. Where heating equipment is supplied by more than one source, the disconnecting means shall be grouped and marked.

(A) Heating Equipment with Supplementary Overcurrent Protection. The disconnecting means for fixed electric space-heating equipment with supplementary overcurrent protection shall be within sight from the supplementary overcurrent protective device(s), on the supply side of these devices, if fuses, and, in addition, shall comply with either 424.19(A)(1) or (A)(2).

(1) Heater Containing No Motor Rated Over 1/8 Horsepower. The above disconnecting means or unit switches complying with 424.19(C) shall be permitted to serve as the required disconnecting means for both the motor controller(s) and heater under either of the following conditions:

- (1) The disconnecting means provided is also within sight from the motor controller(s) and the heater.
- (2) The disconnecting means provided is capable of being locked in the open position.

(2) Heater Containing a Motor(s) Rated Over 1/8 Horsepower. The above disconnecting means shall be permitted to serve as the required disconnecting means for both the motor controller(s) and heater by one of the following means:

- (1) Where the disconnecting means is also in sight from the motor controller(s) and the heater.
- (2) Where the disconnecting means is not within sight from the heater, a separate disconnecting means shall be installed, or the disconnecting means shall be capable

of being locked in the open position, or unit switches complying with 424.19(C) shall be permitted.

- (4) Where the motor is not in sight from the motor controller location, 430.102(B) of the *NEC* shall apply.

(B) Heating Equipment Without Supplementary Overcurrent Protection.

(1) Without Motor or with Motor Not Over 1/8 Horsepower. For fixed electric space-heating equipment without a motor rated over 1/8 hp, the branch-circuit switch or circuit breaker shall be permitted to serve as the disconnecting means where the switch or circuit breaker is within sight from the heater or is capable of being locked in the open position.

(2) Over 1/8 Horsepower. For motor-driven electric space-heating equipment with a motor rated over 1/8 hp, a disconnecting means shall be located within sight from the motor controller or shall be permitted to comply with the requirements in 424.19(A)(2).

(C) Unit Switch(es) as Disconnecting Means. A unit switch(es) with a marked “off” position that is part of a fixed heater and disconnects all ungrounded conductors shall be permitted as the disconnecting means required by this article where other means for disconnection are provided in the types of occupancies in 424.19(C)(2) through (C)(4).

(2) Two-Family Dwellings. In two-family dwellings, the other disconnecting means shall be permitted either inside or outside of the dwelling unit in which the fixed heater is installed. In this case, an individual switch or circuit breaker for the dwelling unit shall be permitted and shall also be permitted to control lamps and appliances.

(3) One-Family Dwellings. In one-family dwellings, the service disconnecting means shall be permitted to be the other disconnecting means.

(4) Other Occupancies. In other occupancies, the branch-circuit switch or circuit breaker, where readily accessible for servicing of the fixed heater, shall be permitted as the other disconnecting means.

424.20 Thermostatically Controlled Switching Devices.

(A) Serving as Both Controllers and Disconnecting Means. Thermostatically controlled switching devices and combination thermostats and manually controlled switches shall be permitted to serve as both controllers and disconnecting means, provided all of the following conditions are met:

- (1) Provided with a marked “off” position
- (2) Directly open all ungrounded conductors when manually placed in the “off” position

- (3) Designed so that the circuit cannot be energized automatically after the device has been manually placed in the “off” position
- (4) Located as specified in 424.19

(B) Thermostats That Do Not Directly Interrupt All Ungrounded Conductors. Thermostats that do not directly interrupt all ungrounded conductors and thermostats that operate remote-control circuits shall not be required to meet the requirements of 424.20(A). These devices shall not be permitted as the disconnecting means.

424.21 Switch and Circuit Breaker to Be Indicating. Switches and circuit breakers used as disconnecting means shall be of the indicating type.

424.22 Overcurrent Protection.

(A) Branch-Circuit Devices. Electric space-heating equipment, other than such motor-operated equipment as required by Article 430 of the *NEC* and Article 440 to have additional overcurrent protection, shall be permitted to be protected against overcurrent where supplied by one of the branch circuits in Article 210.

(B) Resistance Elements. Resistance-type heating elements in electric space-heating equipment shall be protected at not more than 60 amperes. Equipment rated more than 48 amperes and employing such elements shall have the heating elements subdivided, and each subdivided load shall not exceed 48 amperes. Where a subdivided load is less than 48 amperes, the rating of the supplementary overcurrent protective device shall comply with 424.3(B). A boiler employing resistance-type immersion heating elements contained in an ASME rated and stamped vessel shall be permitted to comply with 424.72(A) in the *NEC*.

(C) Overcurrent Protective Devices. The supplementary overcurrent protective devices for the subdivided loads specified in 424.22(B) shall be (1) factory-installed within or on the heater enclosure or supplied for use with the heater as a separate assembly by the heater manufacturer; (2) accessible, but shall not be required to be readily accessible; and (3) suitable for branch-circuit protection.

FPN: See 240.10 in the *NEC*.

Where cartridge fuses are used to provide this overcurrent protection, a single disconnecting means shall be permitted to be used for the several subdivided loads.

FPN No. 1: For supplementary overcurrent protection, see 240.10 in the *NEC*.

FPN No. 2: For disconnecting means for cartridge fuses in circuits of any voltage, see 240.40 in the *NEC*.

(D) Branch-Circuit Conductors. The conductors supplying the supplementary overcurrent protective devices shall be considered branch-circuit conductors.

Where the heaters are rated 50 kW or more, the conductors supplying the supplementary overcurrent protective devices specified in 424.22(C) shall be permitted to be sized at not less than 100 percent of the nameplate rating of the heater, provided all of the following conditions are met:

- (1) The heater is marked with a minimum conductor size.
- (2) The conductors are not smaller than the marked minimum size.
- (3) A temperature-actuated device controls the cyclic operation of the equipment.

(E) Conductors for Subdivided Loads. Field-wired conductors between the heater and the supplementary overcurrent protective devices shall be sized at not less than 125 percent of the load served. The supplementary overcurrent protective devices specified in 424.22(C) shall protect these conductors in accordance with 240.4.

Where the heaters are rated 50 kW or more, the ampacity of field-wired conductors between the heater and the supplementary overcurrent protective devices shall be permitted to be not less than 100 percent of the load of their respective subdivided circuits, provided all of the following conditions are met:

- (1) The heater is marked with a minimum conductor size.
- (2) The conductors are not smaller than the marked minimum size.
- (3) A temperature-activated device controls the cyclic operation of the equipment.

IV. Marking of Heating Equipment

424.28 Nameplate.

(A) Marking Required. Each unit of fixed electric space-heating equipment shall be provided with a nameplate giving the identifying name and the normal rating in volts and watts or in volts and amperes.

Electric space-heating equipment intended for use on alternating current only or direct current only shall be marked to so indicate. The marking of equipment consisting of motors over $\frac{1}{8}$ hp and other loads shall specify the rating of the motor in volts, amperes, and frequency, and the heating load in volts and watts or in volts and amperes.

(B) Location. This nameplate shall be located so as to be visible or easily accessible after installation.

424.29 Marking of Heating Elements. All heating elements that are replaceable in the field and are part of an electric heater shall be legibly marked with the ratings in volts and watts or in volts and amperes.

V. Electric Space-Heating Cables

424.34 Heating Cable Construction. Heating cables shall be furnished complete with factory-assembled nonheating leads at least 2.1 m (7 ft) in length.

424.35 Marking of Heating Cables. Each unit shall be marked with the identifying name or identification symbol, catalog number, and ratings in volts and watts or in volts and amperes.

Each unit length of heating cable shall have a permanent legible marking on each nonheating lead located within 75 mm (3 in.) of the terminal end. The lead wire shall have the following color identification to indicate the circuit voltage on which it is to be used:

- (1) 120 volt, nominal — yellow
- (2) 208 volt, nominal — blue
- (3) 240 volt, nominal — red
- (4) 277 volt, nominal — brown
- (5) 480 volt, nominal — orange

424.36 Clearances of Wiring in Ceilings. Wiring located above heated ceilings shall be spaced not less than 50 mm (2 in.) above the heated ceiling and shall be considered as operating at an ambient temperature of 50°C (122°F). The ampacity of conductors shall be calculated on the basis of the correction factors shown in the 0–2000 volt ampacity tables of Article 310. If this wiring is located above thermal insulation having a minimum thickness of 50 mm (2 in.), the wiring shall not require correction for temperature.

424.38 Area Restrictions.

(A) Shall Not Extend Beyond the Room or Area. Heating cables shall not extend beyond the room or area in which they originate.

(B) Uses Prohibited. Heating cables shall not be installed in the following:

- (1) In closets
- (2) Over walls
- (3) Over partitions that extend to the ceiling, unless they are isolated single runs of embedded cable
- (4) Over cabinets whose clearance from the ceiling is less than the minimum horizontal dimension of the cabinet to the nearest cabinet edge that is open to the room or area

(C) In Closet Ceilings as Low-Temperature Heat Sources to Control Relative Humidity. The provisions of 424.38(B) shall not prevent the use of cable in closet ceilings as low-temperature heat sources to control relative humidity, provided they are used only in those portions of the ceiling that

are unobstructed to the floor by shelves or other permanent luminaires (fixtures).

424.39 Clearance from Other Objects and Openings. Heating elements of cables shall be separated at least 200 mm (8 in.) from the edge of outlet boxes and junction boxes that are to be used for mounting surface luminaires (lighting fixtures). A clearance of not less than 50 mm (2 in.) shall be provided from recessed luminaires (fixtures) and their trims, ventilating openings, and other such openings in room surfaces. Sufficient area shall be provided to ensure that no heating cable is covered by any surface-mounted units.

424.40 Splices. Embedded cables shall be spliced only where necessary and only by approved means, and in no case shall the length of the heating cable be altered.

424.41 Installation of Heating Cables on Dry Board, in Plaster, and on Concrete Ceilings.

(A) In Walls. Cables shall not be installed in walls unless it is necessary for an isolated single run of cable to be installed down a vertical surface to reach a dropped ceiling.

(B) Adjacent Runs. Adjacent runs of cable not exceeding 9 watts/m (2¾ watts/ft) shall not be installed less than 38 mm (1½ in.) on centers.

(C) Surfaces to Be Applied. Heating cables shall be applied only to gypsum board, plaster lath, or other fire-resistant material. With metal lath or other electrically conductive surfaces, a coat of plaster shall be applied to completely separate the metal lath or conductive surface from the cable.

FPN: See also 424.41(F).

(D) Splices. All heating cables, the splice between the heating cable and nonheating leads, and 75-mm (3-in.) minimum of the nonheating lead at the splice shall be embedded in plaster or dry board in the same manner as the heating cable.

(E) Ceiling Surface. The entire ceiling surface shall have a finish of thermally noninsulating sand plaster that has a nominal thickness of 13 mm (½ in.), or other noninsulating material identified as suitable for this use and applied according to specified thickness and directions.

(F) Secured. Cables shall be secured by means of approved stapling, tape, plaster, nonmetallic spreaders, or other approved means either at intervals not exceeding 400 mm (16 in.) or at intervals not exceeding 1.8 m (6 ft) for cables identified for such use. Staples or metal fasteners that straddle the cable shall not be used with metal lath or other electrically conductive surfaces.

(G) Dry Board Installations. In dry board installations, the entire ceiling below the heating cable shall be covered with gypsum board not exceeding 13 mm (½ in.) thickness. The void between the upper layer of gypsum board, plaster lath, or other fire-resistant material and the surface layer of gypsum board shall be completely filled with thermally conductive, nonshrinking plaster or other approved material or equivalent thermal conductivity.

(H) Free from Contact with Conductive Surfaces. Cables shall be kept free from contact with metal or other electrically conductive surfaces.

(I) Joists. In dry board applications, cable shall be installed parallel to the joist, leaving a clear space centered under the joist of 65 mm (2½ in.) (width) between centers of adjacent runs of cable. A surface layer of gypsum board shall be mounted so that the nails or other fasteners do not pierce the heating cable.

(J) Crossing Joists. Cables shall cross joists only at the ends of the room unless the cable is required to cross joists elsewhere in order to satisfy the manufacturer's instructions that the installer avoid placing the cable too close to ceiling penetrations and luminaires (lighting fixtures).

424.42 Finished Ceilings. Finished ceilings shall not be covered with decorative panels or beams constructed of materials that have thermal insulating properties, such as wood, fiber, or plastic. Finished ceilings shall be permitted to be covered with paint, wallpaper, or other approved surface finishes.

424.43 Installation of Nonheating Leads of Cables.

(A) Free Nonheating Leads. Free nonheating leads of cables shall be installed in accordance with approved wiring methods from the junction box to a location within the ceiling. Such installations shall be permitted to be single conductors in approved raceways, single or multiconductor Type UF, Type NMC, Type MI, or other approved conductors.

(B) Leads in Junction Box. Not less than 150 mm (6 in.) of free nonheating lead shall be within the junction box. The marking of the leads shall be visible in the junction box.

(C) Excess Leads. Excess leads of heating cables shall not be cut but shall be secured to the underside of the ceiling and embedded in plaster or other approved material, leaving only a length sufficient to reach the junction box with not less than 150 mm (6 in.) of free lead within the box.

424.44 Installation of Cables in Concrete or Poured Masonry Floors.

(A) Watts per Linear Foot. Constant wattage heating cables shall not exceed 54 watts/linear meter (16½ watts/linear foot) of cable.

(B) Spacing Between Adjacent Runs. The spacing between adjacent runs of cable shall not be less than 25 mm (1 in.) on centers.

(C) Secured in Place. Cables shall be secured in place by nonmetallic frames or spreaders or other approved means while the concrete or other finish is applied.

Cables shall not be installed where they bridge expansion joints unless protected from expansion and contraction.

(D) Spacings Between Heating Cable and Metal Embedded in the Floor. Spacings shall be maintained between the heating cable and metal embedded in the floor, unless the cable is a grounded metal-clad cable.

(E) Leads Protected. Leads shall be protected where they leave the floor by rigid metal conduit, intermediate metal conduit, rigid nonmetallic conduit, electrical metallic tubing, or by other approved means.

(F) Bushings or Approved Fittings. Bushings or approved fittings shall be used where the leads emerge within the floor slab.

(G) Ground-Fault Circuit-Interrupter Protection. Ground-fault circuit-interrupter protection for personnel shall be provided for cables installed in electrically heated floors of bathrooms and in hydromassage bathtub locations.

424.45 Inspection and Tests. Cable installations shall be made with due care to prevent damage to the cable assembly and shall be inspected and approved before cables are covered or concealed.

VI. Duct Heaters

424.57 General. Part VI shall apply to any heater mounted in the airstream of a forced-air system where the air-moving unit is not provided as an integral part of the equipment.

424.58 Identification. Heaters installed in an air duct shall be identified as suitable for the installation.

424.59 Airflow. Means shall be provided to ensure uniform and adequate airflow over the face of the heater in accordance with the manufacturer's instructions.

FPN: Heaters installed within 1.2 m (4 ft) of the outlet of an air-moving device, heat pump, air conditioner, elbows, baffle plates, or other obstructions in ductwork may require turning vanes, pressure plates, or other devices on the inlet side of the duct heater to ensure an even distribution of air over the face of the heater.

424.60 Elevated Inlet Temperature. Duct heaters intended for use with elevated inlet air temperature shall be identified as suitable for use at the elevated temperatures.

424.61 Installation of Duct Heaters with Heat Pumps and Air Conditioners. Heat pumps and air conditioners having duct heaters closer than 1.2 m (4 ft) to the heat pump or air conditioner shall have both the duct heater and heat pump or air conditioner identified as suitable for such installation and so marked.

424.62 Condensation. Duct heaters used with air conditioners or other air-cooling equipment that could result in condensation of moisture shall be identified as suitable for use with air conditioners.

424.63 Fan Circuit Interlock. Means shall be provided to ensure that the fan circuit is energized when any heater circuit is energized. However, time- or temperature-controlled delay in energizing the fan motor shall be permitted.

424.64 Limit Controls. Each duct heater shall be provided with an approved, integral, automatic-reset temperature-limiting control or controllers to de-energize the circuit or circuits.

In addition, an integral independent supplementary control or controllers shall be provided in each duct heater that disconnects a sufficient number of conductors to interrupt current flow. This device shall be manually resettable or replaceable.

424.65 Location of Disconnecting Means. Duct heater controller equipment shall be either accessible with the disconnecting means installed at or within sight from the controller or as permitted by 424.19(A).

424.66 Installation. Duct heaters shall be installed in accordance with the manufacturer's instructions in such a manner that operation does not create a hazard to persons or property. Furthermore, duct heaters shall be located with respect to building construction and other equipment so as to permit access to the heater. Sufficient clearance shall be maintained to permit replacement of controls and heating elements and for adjusting and cleaning of controls and other parts requiring such attention. See 110.26.

FPN: For additional installation information, see NFPA 90A-2002, *Standard for the Installation of Air-Conditioning and Ventilating Systems*, and NFPA 90B-2002, *Standard for the Installation of Warm Air Heating and Air-Conditioning Systems*.

VII. Resistance-Type Boilers

Installation shall conform to the requirements of Article 424 Part VII in the 2005 *National Electrical Code* (NFPA 70-2005)

IX. Electric Radiant Heating Panels and Heating Panel Sets

424.90 Scope. The provisions of Part IX of this article shall apply to radiant heating panels and heating panel sets.

424.91 Definitions.

Heating Panel. A complete assembly provided with a junction box or a length of flexible conduit for connection to a branch circuit.

Heating Panel Set. A rigid or nonrigid assembly provided with nonheating leads or a terminal junction assembly identified as being suitable for connection to a wiring system.

424.92 Markings.

(A) Location. Markings shall be permanent and in a location that is visible prior to application of panel finish.

(B) Identified as Suitable. Each unit shall be identified as suitable for the installation.

(C) Required Markings. Each unit shall be marked with the identifying name or identification symbol, catalog number, and rating in volts and watts or in volts and amperes.

(D) Labels Provided by Manufacturer. The manufacturers of heating panels or heating panel sets shall provide marking labels that indicate that the space-heating installation incorporates heating panels or heating panel sets and instructions that the labels shall be affixed to the panelboards to identify which branch circuits supply the circuits to those space-heating installations. If the heating panels and heating panel set installations are visible and distinguishable after installation, the labels shall not be required to be provided and affixed to the panelboards.

424.93 Installation.

(A) General.

(1) Manufacturer's Instructions. Heating panels and heating panel sets shall be installed in accordance with the manufacturer's instructions.

(2) Locations Not Permitted. The heating portion shall not be installed as follows:

- (1) In or behind surfaces where subject to physical damage
- (2) Run through or above walls, partitions, cupboards, or similar portions of structures that extend to the ceiling
- (3) Run in or through thermal insulation, but shall be permitted to be in contact with the surface of thermal insulation

(3) Separation from Outlets for Luminaires (Lighting Fixtures). Edges of panels and panel sets shall be separated by not less than 200 mm (8 in.) from the edges of any outlet boxes and junction boxes that are to be used for mounting surface luminaires (lighting fixtures). A clearance of not less than 50 mm (2 in.) shall be provided from recessed luminaires (fixtures) and their trims, ventilating openings, and other such openings in room surfaces, unless the heating

panels and panel sets are listed and marked for lesser clearances, in which case they shall be permitted to be installed at the marked clearances. Sufficient area shall be provided to ensure that no heating panel or heating panel set is to be covered by any surface-mounted units.

(4) Surfaces Covering Heating Panels. After the heating panels or heating panel sets are installed and inspected, it shall be permitted to install a surface that has been identified by the manufacturer's instructions as being suitable for the installation. The surface shall be secured so that the nails or other fastenings do not pierce the heating panels or heating panel sets.

(5) Surface Coverings. Surfaces permitted by 424.93(A)(4) shall be permitted to be covered with paint, wallpaper, or other approved surfaces identified in the manufacturer's instructions as being suitable.

(B) Heating Panel Sets.

(1) Mounting Location. Heating panel sets shall be permitted to be secured to the lower face of joists or mounted in between joists, headers, or nailing strips.

(2) Parallel to Joists or Nailing Strips. Heating panel sets shall be installed parallel to joists or nailing strips.

(3) Installation of Nails, Staples, or Other Fasteners. Nailing or stapling of heating panel sets shall be done only through the unheated portions provided for this purpose. Heating panel sets shall not be cut through or nailed through any point closer than 6 mm (¼ in.) to the element. Nails, staples, or other fasteners shall not be used where they penetrate current-carrying parts.

(4) Installed as Complete Unit. Heating panel sets shall be installed as complete units unless identified as suitable for field cutting in an approved manner.

424.94 Clearances of Wiring in Ceilings. Wiring located above heated ceilings shall be spaced not less than 50 mm (2 in.) above the heated ceiling and shall be considered as operating at an ambient of 50°C (122°F). The ampacity shall be calculated on the basis of the correction factors given in the 0–2000 volt ampacity tables of Article 310. If this wiring is located above thermal insulations having a minimum thickness of 50 mm (2 in.), the wiring shall not require correction for temperature.

424.95 Location of Branch-Circuit and Feeder Wiring in Walls.

(A) Exterior Walls. Wiring methods shall comply with Article 300 and 310.10.

(B) Interior Walls. Any wiring behind heating panels or heating panel sets located in interior walls or partitions shall

be considered as operating at an ambient temperature of 40°C (104°F), and the ampacity shall be calculated on the basis of the correction factors given in the 0–2000 volt ampacity tables of Article 310.

424.96 Connection to Branch-Circuit Conductors.

(A) General. Heating panels or heating panel sets assembled together in the field to form a heating installation in one room or area shall be connected in accordance with the manufacturer's instructions.

(B) Heating Panels. Heating panels shall be connected to branch-circuit wiring by an approved wiring method.

(C) Heating Panel Sets.

(1) Connection to Branch Circuit Wiring. Heating panel sets shall be connected to branch-circuit wiring by a method identified as being suitable for the purpose.

(2) Panel Sets with Terminal Junction Assembly. A heating panel set provided with terminal junction assembly shall be permitted to have the nonheating leads attached at the time of installation in accordance with the manufacturer's instructions.

424.97 Nonheating Leads. Excess nonheating leads of heating panels or heating panel sets shall be permitted to be cut to the required length. They shall meet the installation requirements of the wiring method employed in accordance with 424.96. Nonheating leads shall be an integral part of a heating panel and a heating panel set and shall not be subjected to the ampacity requirements of 424.3(B) for branch circuits.

424.98 Installation in Concrete or Poured Masonry.

(A) Maximum Heated Area. Heating panels or heating panel sets shall not exceed 355 watts/m² (33 watts/ft²) of heated area.

(B) Secured in Place and Identified as Suitable. Heating panels or heating panel sets shall be secured in place by means specified in the manufacturer's instructions and identified as suitable for the installation.

(C) Expansion Joints. Heating panels or heating panel sets shall not be installed where they bridge expansion joints unless provision is made for expansion and contraction.

(D) Spacings. Spacings shall be maintained between heating panels or heating panel sets and metal embedded in the floor. Grounded metal-clad heating panels shall be permitted to be in contact with metal embedded in the floor.

(E) Protection of Leads. Leads shall be protected where they leave the floor by rigid metal conduit, intermediate

metal conduit, rigid nonmetallic conduit, or electrical metallic tubing, or by other approved means.

(F) Bushings or Fittings Required. Bushings or approved fittings shall be used where the leads emerge within the floor slabs.

ARTICLE 440 Air-Conditioning and Refrigerating Equipment

I. General

440.1 Scope. The provisions of this article apply to electric motor-driven air-conditioning and refrigerating equipment and to the branch circuits and controllers for such equipment. It provides for the special considerations necessary for circuits supplying hermetic refrigerant motor-compressors and for any air-conditioning or refrigerating equipment that is supplied from a branch circuit that supplies a hermetic refrigerant motor-compressor.

440.2 Definitions.

Branch-Circuit Selection Current. The value in amperes to be used instead of the rated-load current in determining the ratings of motor branch-circuit conductors, disconnecting means, controllers, and branch-circuit short-circuit and ground-fault protective devices wherever the running overload protective device permits a sustained current greater than the specified percentage of the rated-load current. The value of branch-circuit selection current will always be equal to or greater than the marked rated-load current.

Hermetic Refrigerant Motor-Compressor. A combination consisting of a compressor and motor, both of which are enclosed in the same housing, with no external shaft or shaft seals, the motor operating in the refrigerant.

Leakage Current Detection and Interruption (LCDI) Protection. A device provided in a power supply cord or cord set that senses leakage current flowing between or from the cord conductors and interrupts the circuit at a predetermined level of leakage current.

Rated-Load Current. The rated-load current for a hermetic refrigerant motor-compressor is the current resulting when the motor-compressor is operated at the rated load, rated voltage, and rated frequency of the equipment it serves.

440.3 Other Articles.

(A) Article 430. These provisions are in addition to, or amendatory of, the provisions of Article 430 in the *NEC* and

other articles in this *Code*, which apply except as modified in this article.

(B) Articles 422, 424, or 430. The rules of Articles 422, 424, or 430 in the *NEC*, as applicable, shall apply to air-conditioning and refrigerating equipment that does not incorporate a hermetic refrigerant motor-compressor. This equipment includes devices that employ refrigeration compressors driven by conventional motors, furnaces with air-conditioning evaporator coils installed, fan-coil units, remote forced air-cooled condensers, remote commercial refrigerators, and so forth.

(C) Article 422. Equipment such as room air conditioners, household refrigerators and freezers, drinking water coolers, and beverage dispensers shall be considered appliances, and the provisions of Article 422 shall also apply.

440.6 Ampacity and Rating. The size of conductors for equipment covered by this article shall be selected from Table 310.16 through Table 310.19 in the *NEC* or calculated in accordance with 310.15 as applicable. The required ampacity of conductors and rating of equipment shall be determined according to 440.6(A) and 440.6(B).

(A) Hermetic Refrigerant Motor-Compressor. For a hermetic refrigerant motor-compressor, the rated-load current marked on the nameplate of the equipment in which the motor-compressor is employed shall be used in determining the rating or ampacity of the disconnecting means, the branch-circuit conductors, the controller, the branch-circuit short-circuit and ground-fault protection, and the separate motor overload protection. Where no rated-load current is shown on the equipment nameplate, the rated-load current shown on the compressor nameplate shall be used.

Exception No. 1: Where so marked, the branch-circuit selection current shall be used instead of the rated-load current to determine the rating or ampacity of the disconnecting means, the branch-circuit conductors, the controller, and the branch-circuit short-circuit and ground-fault protection.

Exception No. 2: For cord-and-plug-connected equipment, the nameplate marking shall be used in accordance with 440.22(B), Exception No. 2.

FPN: For disconnecting means and controllers, see 440.12 and 440.41.

(B) Multimotor Equipment. For multimotor equipment employing a shaded-pole or permanent split-capacitor-type fan or blower motor, the full-load current for such motor marked on the nameplate of the equipment in which the fan or blower motor is employed shall be used instead of the horsepower rating to determine the ampacity or rating of the disconnecting means, the branch-circuit conductors, the controller, the branch-circuit short-circuit and ground-fault

protection, and the separate overload protection. This marking on the equipment nameplate shall not be less than the current marked on the fan or blower motor nameplate.

440.7 Highest Rated (Largest) Motor. In determining compliance with this article and with 430.24, 430.53(B) and 430.53(C), and 430.62(A) in the *NEC*, the highest rated (largest) motor shall be considered to be the motor that has the highest rated-load current. Where two or more motors have the same highest rated-load current, only one of them shall be considered as the highest rated (largest) motor. For other than hermetic refrigerant motor-compressors, and fan or blower motors as covered in 440.6(B), the full-load current used to determine the highest rated motor shall be the equivalent value corresponding to the motor horsepower rating selected from Table 430.248, Table 430.249, or Table 430.250 in the *NEC*.

Exception: Where so marked, the branch-circuit selection current shall be used instead of the rated-load current in determining the highest rated (largest) motor-compressor.

440.8 Single Machine. An air-conditioning or refrigerating system shall be considered to be a single machine under the provisions of 430.87, Exception, and 430.112, Exception in the *NEC*. The motors shall be permitted to be located remotely from each other.

II. Disconnecting Means

440.11 General. The provisions of Part II are intended to require disconnecting means capable of disconnecting air-conditioning and refrigerating equipment, including motor-compressors and controllers from the circuit conductors.

440.12 Rating and Interrupting Capacity.

(A) Hermetic Refrigerant Motor-Compressor. A disconnecting means serving a hermetic refrigerant motor-compressor shall be selected on the basis of the nameplate rated-load current or branch-circuit selection current, whichever is greater, and locked-rotor current, respectively, of the motor-compressor as follows.

(1) Ampere Rating. The ampere rating shall be at least 115 percent of the nameplate rated-load current or branch-circuit selection current, whichever is greater.

Exception: A listed nonfused motor circuit switch having a horsepower rating not less than the equivalent horsepower determined in accordance with 440.12(A)(2) shall be permitted to have an ampere rating less than 115 percent of the specified current.

(2) Equivalent Horsepower. To determine the equivalent horsepower in complying with the requirements of 430.109

in the *NEC*, the horsepower rating shall be selected from Table 430.248, Table 430.249, or Table 430.250 in the *NEC* corresponding to the rated-load current or branch-circuit selection current, whichever is greater, and also the horsepower rating from Table 430.251(A) or Table 430.251(B) in the *NEC* corresponding to the locked-rotor current. In case the nameplate rated-load current or branch-circuit selection current and locked-rotor current do not correspond to the currents shown in Table 430.248, Table 430.249, Table 430.250, Table 430.251(A), or Table 430.251(B) in the *NEC*, the horsepower rating corresponding to the next higher value shall be selected. In case different horsepower ratings are obtained when applying these tables, a horsepower rating at least equal to the larger of the values obtained shall be selected.

(B) Combination Loads. Where the combined load of two or more hermetic refrigerant motor-compressors or one or more hermetic refrigerant motor-compressor with other motors or loads may be simultaneous on a single disconnecting means, the rating for the disconnecting means shall be determined in accordance with 440.12(B)(1) and (B)(2).

(1) Horsepower Rating. The horsepower rating of the disconnecting means shall be determined from the sum of all currents, including resistance loads, at the rated-load condition and also at the locked-rotor condition. The combined rated-load current and the combined locked-rotor current so obtained shall be considered as a single motor for the purpose of this requirement as follows.

(a) The full-load current equivalent to the horsepower rating of each motor, other than a hermetic refrigerant motor-compressor, and fan or blower motors as covered in 440.6(B) shall be selected from Table 430.248, Table 430.249, or Table 430.250 in the *NEC*. These full-load currents shall be added to the motor-compressor rated-load current(s) or branch-circuit selection current(s), whichever is greater, and to the rating in amperes of other loads to obtain an equivalent full-load current for the combined load.

(b) The locked-rotor current equivalent to the horsepower rating of each motor, other than a hermetic refrigerant motor-compressor, shall be selected from Table 430.251(A) or Table 430.251(B) in the *NEC*, and, for fan and blower motors of the shaded-pole or permanent split-capacitor type marked with the locked-rotor current, the marked value shall be used. The locked-rotor currents shall be added to the motor-compressor locked-rotor current(s) and to the rating in amperes of other loads to obtain an equivalent locked-rotor current for the combined load. Where two or more motors or other loads such as resistance heaters, or both, cannot be started simultaneously, appropriate combinations of locked-rotor and rated-load current or branch-circuit selection current, whichever is greater, shall be an acceptable

means of determining the equivalent locked-rotor current for the simultaneous combined load.

Exception: Where part of the concurrent load is a resistance load and the disconnecting means is a switch rated in horsepower and amperes, the switch used shall be permitted to have a horsepower rating not less than the combined load to the motor-compressor(s) and other motor(s) at the locked-rotor condition, if the ampere rating of the switch is not less than this locked-rotor load plus the resistance load.

(2) Full-Load Current Equivalent. The ampere rating of the disconnecting means shall be at least 115 percent of the sum of all currents at the rated-load condition determined in accordance with 440.12(B)(1).

Exception: A listed nonfused motor circuit switch having a horsepower rating not less than the equivalent horsepower determined by 440.12(B)(1) shall be permitted to have an ampere rating less than 115 percent of the sum of all currents.

(C) Small Motor-Compressors. For small motor-compressors not having the locked-rotor current marked on the nameplate, or for small motors not covered by Table 430.247, Table 430.248, Table 430.249, or Table 430.250 in the *NEC*, the locked-rotor current shall be assumed to be six times the rated-load current.

(D) Disconnecting Means. Every disconnecting means in the refrigerant motor-compressor circuit between the point of attachment to the feeder and the point of connection to the refrigerant motor-compressor shall comply with the requirements of 440.12.

440.13 Cord-Connected Equipment. For cord-connected equipment such as room air conditioners, household refrigerators and freezers, drinking water coolers, and beverage dispensers, a separable connector or an attachment plug and receptacle shall be permitted to serve as the disconnecting means.

FPN: For room air conditioners, see 440.63.

440.14 Location. Disconnecting means shall be located within sight from and readily accessible from the air-conditioning or refrigerating equipment. The disconnecting means shall be permitted to be installed on or within the air-conditioning or refrigerating equipment.

The disconnecting means shall not be located on panels that are designed to allow access to the air-conditioning or refrigeration equipment.

Exception No. 2: Where an attachment plug and receptacle serve as the disconnecting means in accordance with 440.13, their location shall be accessible but shall not be required to be readily accessible.

FPN: See Parts VII and IX of Article 430 in the *NEC* for additional requirements.

III. Branch-Circuit Short-Circuit and Ground-Fault Protection

440.21 General. The provisions of Part III specify devices intended to protect the branch-circuit conductors, control apparatus, and motors in circuits supplying hermetic refrigerant motor-compressors against overcurrent due to short circuits and grounds. They are in addition to or amendatory of the provisions of Article 240.

440.22 Application and Selection.

(A) Rating or Setting for Individual Motor-Compressor. The motor-compressor branch-circuit short-circuit and ground-fault protective device shall be capable of carrying the starting current of the motor. A protective device having a rating or setting not exceeding 175 percent of the motor-compressor rated-load current or branch-circuit selection current, whichever is greater, shall be permitted, provided that, where the protection specified is not sufficient for the starting current of the motor, the rating or setting shall be permitted to be increased but shall not exceed 225 percent of the motor rated-load current or branch-circuit selection current, whichever is greater.

Exception: The rating of the branch-circuit short-circuit and ground-fault protective device shall not be required to be less than 15 amperes.

(B) Rating or Setting for Equipment. The equipment branch-circuit short-circuit and ground-fault protective device shall be capable of carrying the starting current of the equipment. Where the hermetic refrigerant motor-compressor is the only load on the circuit, the protection shall conform with 440.22(A). Where the equipment incorporates more than one hermetic refrigerant motor-compressor or a hermetic refrigerant motor-compressor and other motors or other loads, the equipment short-circuit and ground-fault protection shall conform with 430.53 in the *NEC* and 440.22(B)(1) and (B)(2).

(1) Motor-Compressor Largest Load. Where a hermetic refrigerant motor-compressor is the largest load connected to the circuit, the rating or setting of the branch-circuit short-circuit and ground-fault protective device shall not exceed the value specified in 440.22(A) for the largest motor-compressor plus the sum of the rated-load current or branch-circuit selection current, whichever is greater, of the other motor-compressor(s) and the ratings of the other loads supplied.

(2) Motor-Compressor Not Largest Load. Where a hermetic refrigerant motor-compressor is not the largest load connected to the circuit, the rating or setting of the branch-circuit short-circuit and ground-fault protective device shall not exceed a value equal to the sum of the rated-load current or branch-circuit selection current, whichever is greater, rating(s) for the motor-compressor(s) plus the value specified

in 430.53(C)(4) in the *NEC* where other motor loads are supplied, or the value specified in 240.4 where only nonmotor loads are supplied in addition to the motor-compressor(s).

Exception No. 1: Equipment that starts and operates on a 15- or 20-ampere 120-volt, or 15-ampere 208- or 240-volt single-phase branch circuit, shall be permitted to be protected by the 15- or 20-ampere overcurrent device protecting the branch circuit, but if the maximum branch-circuit short-circuit and ground-fault protective device rating marked on the equipment is less than these values, the circuit protective device shall not exceed the value marked on the equipment nameplate.

Exception No. 2: The nameplate marking of cord-and-plug-connected equipment rated not greater than 250 volts, single-phase, such as household refrigerators and freezers, drinking water coolers, and beverage dispensers, shall be used in determining the branch-circuit requirements, and each unit shall be considered as a single motor unless the nameplate is marked otherwise.

(C) Protective Device Rating Not to Exceed the Manufacturer's Values. Where maximum protective device ratings shown on a manufacturer's overload relay table for use with a motor controller are less than the rating or setting selected in accordance with 440.22(A) and 440.22(B), the protective device rating shall not exceed the manufacturer's values marked on the equipment.

IV. Branch-Circuit Conductors

440.31 General. The provisions of Part IV and Article 310 specify ampacities of conductors required to carry the motor current without overheating under the conditions specified, except as modified in 440.6(A), Exception No. 1.

The provisions of these articles shall not apply to integral conductors of motors, motor controllers and the like, or to conductors that form an integral part of approved equipment.

FPN: See 300.1(B) and 310.1 for similar requirements.

440.32 Single Motor-Compressor. Branch-circuit conductors supplying a single motor-compressor shall have an ampacity not less than 125 percent of either the motor-compressor rated-load current or the branch-circuit selection current, whichever is greater.

440.33 Motor-Compressor(s) With or Without Additional Motor Loads. Conductors supplying one or more motor-compressor(s) with or without an additional load(s) shall have an ampacity not less than the sum of the rated-load or branch-circuit selection current ratings, whichever is larger, of all the motor-compressors plus the full-load currents of the other motors, plus 25 percent of the highest motor or motor-compressor rating in the group.

Exception No. 1: Where the circuitry is interlocked so as to prevent the starting and running of a second motor-compressor or group of motor-compressors, the conductor size shall be determined from the largest motor-compressor or group of motor-compressors that is to be operated at a given time.

Exception No. 2: The branch circuit conductors for room air conditioners shall be in accordance with Part VII of Article 440.

440.34 Combination Load. Conductors supplying a motor-compressor load in addition to a lighting or appliance load as calculated from Article 220 and other applicable articles shall have an ampacity sufficient for the lighting or appliance load plus the required ampacity for the motor-compressor load determined in accordance with 440.33 or, for a single motor-compressor, in accordance with 440.32.

Exception: Where the circuitry is interlocked so as to prevent simultaneous operation of the motor-compressor(s) and all other loads connected, the conductor size shall be determined from the largest size required for the motor-compressor(s) and other loads to be operated at a given time.

440.35 Multimotor and Combination-Load Equipment. The ampacity of the conductors supplying multimotor and combination-load equipment shall not be less than the minimum circuit ampacity marked on the equipment in accordance with 440.4(B) in the *NEC*.

V. Controllers for Motor-Compressors

440.41 Rating.

(A) Motor-Compressor Controller. A motor-compressor controller shall have both a continuous-duty full-load current rating and a locked-rotor current rating not less than the nameplate rated-load current or branch-circuit selection current, whichever is greater, and locked-rotor current, respectively, of the compressor. In case the motor controller is rated in horsepower but is without one or both of the foregoing current ratings, equivalent currents shall be determined from the ratings as follows. Table 430.248, Table 430.249, and Table 430.250 in the *NEC* shall be used to determine the equivalent full-load current rating. Table 430.251(A) and Table 430.251(B) in the *NEC* shall be used to determine the equivalent locked-rotor current ratings.

(B) Controller Serving More Than One Load. A controller serving more than one motor-compressor or a motor-compressor and other loads shall have a continuous-duty full-load current rating and a locked-rotor current rating not less than the combined load as determined in accordance with 440.12(B).

VI. Motor-Compressor and Branch-Circuit Overload Protection

440.51 General. The provisions of Part VI specify devices intended to protect the motor-compressor, the motor-control apparatus, and the branch-circuit conductors against excessive heating due to motor overload and failure to start.

FPN: See 240.4(G) for application of Parts III and VI of Article 440.

440.52 Application and Selection.

(A) Protection of Motor-Compressor. Each motor-compressor shall be protected against overload and failure to start by one of the following means:

- (1) A separate overload relay that is responsive to motor-compressor current. This device shall be selected to trip at not more than 140 percent of the motor-compressor rated-load current.
- (2) A thermal protector integral with the motor-compressor, approved for use with the motor-compressor that it protects on the basis that it will prevent dangerous overheating of the motor-compressor due to overload and failure to start. If the current-interrupting device is separate from the motor-compressor and its control circuit is operated by a protective device integral with the motor-compressor, it shall be arranged so that the opening of the control circuit will result in interruption of current to the motor-compressor.
- (3) A fuse or inverse time circuit breaker responsive to motor current, which shall also be permitted to serve as the branch-circuit short-circuit and ground-fault protective device. This device shall be rated at not more than 125 percent of the motor-compressor rated-load current. It shall have sufficient time delay to permit the motor-compressor to start and accelerate its load. The equipment or the motor-compressor shall be marked with this maximum branch-circuit fuse or inverse time circuit breaker rating.
- (4) A protective system, furnished or specified and approved for use with the motor-compressor that it protects on the basis that it will prevent dangerous overheating of the motor-compressor due to overload and failure to start. If the current-interrupting device is separate from the motor-compressor and its control circuit is operated by a protective device that is not integral with the current-interrupting device, it shall be arranged so that the opening of the control circuit will result in interruption of current to the motor-compressor.

(B) Protection of Motor-Compressor Control Apparatus and Branch-Circuit Conductors. The motor-compressor controller(s), the disconnecting means, and the branch-circuit conductors shall be protected against overcurrent due

to motor overload and failure to start by one of the following means, which shall be permitted to be the same device or system protecting the motor-compressor in accordance with 440.52(A):

Exception: Overload protection of motor-compressors and equipment on 15- and 20-ampere, single-phase, branch circuits shall be permitted to be in accordance with 440.54 and 440.55.

- (1) An overload relay selected in accordance with 440.52(A)(1)
- (2) A thermal protector applied in accordance with 440.52(A)(2), that will not permit a continuous current in excess of 156 percent of the marked rated-load current or branch-circuit selection current
- (3) A fuse or inverse time circuit breaker selected in accordance with 440.52(A)(3)
- (4) A protective system, in accordance with 440.52(A)(4), that will not permit a continuous current in excess of 156 percent of the marked rated-load current or branch-circuit selection current

440.53 Overload Relays. Overload relays and other devices for motor overload protection that are not capable of opening short circuits shall be protected by fuses or inverse time circuit breakers with ratings or settings in accordance with Part III unless approved for group installation or for part-winding motors and marked to indicate the maximum size of fuse or inverse time circuit breaker by which they shall be protected.

Exception: The fuse or inverse time circuit breaker size marking shall be permitted on the nameplate of approved equipment in which the overload relay or other overload device is used.

440.54 Motor-Compressors and Equipment on 15- or 20-Ampere Branch Circuits — Not Cord-and-Attachment-Plug-Connected. Overload protection for motor-compressors and equipment used on 15- or 20-ampere 120-volt, or 15-ampere 208- or 240-volt single-phase branch circuits as permitted in Article 210 shall be permitted as indicated in 440.54(A) and 440.54(B).

(A) Overload Protection. The motor-compressor shall be provided with overload protection selected as specified in 440.52(A). Both the controller and motor overload protective device shall be approved for installation with the short-circuit and ground-fault protective device for the branch circuit to which the equipment is connected.

(B) Time Delay. The short-circuit and ground-fault protective device protecting the branch circuit shall have sufficient time delay to permit the motor-compressor and other motors to start and accelerate their loads.

440.55 Cord-and-Attachment-Plug-Connected Motor-Compressors and Equipment on 15- or 20-Ampere Branch Circuits. Overload protection for motor-compressors and equipment that are cord-and-attachment-plug-connected and used on 15- or 20-ampere 120-volt, or 15-ampere 208- or 240-volt, single-phase branch circuits as permitted in Article 210 shall be permitted as indicated in 440.55(A), (B), and (C).

(A) Overload Protection. The motor-compressor shall be provided with overload protection as specified in 440.52(A). Both the controller and the motor overload protective device shall be approved for installation with the short-circuit and ground-fault protective device for the branch circuit to which the equipment is connected.

(B) Attachment Plug and Receptacle Rating. The rating of the attachment plug and receptacle shall not exceed 20 amperes at 125 volts or 15 amperes at 250 volts.

(C) Time Delay. The short-circuit and ground-fault protective device protecting the branch circuit shall have sufficient time delay to permit the motor-compressor and other motors to start and accelerate their loads.

VII. Provisions for Room Air Conditioners

440.60 General. The provisions of Part VII shall apply to electrically energized room air conditioners that control temperature and humidity. For the purpose of Part VII, a room air conditioner (with or without provisions for heating) shall be considered as an ac appliance of the air-cooled window, console, or in-wall type that is installed in the conditioned room and that incorporates a hermetic refrigerant motor-compressor(s). The provisions of Part VII cover equipment rated not over 250 volts, single phase, and such equipment shall be permitted to be cord-and-attachment-plug-connected.

A room air conditioner that is rated three phase or rated over 250 volts shall be directly connected to a wiring method recognized in Chapter 3, and provisions of Part VII shall not apply.

440.61 Grounding. Room air conditioners shall be grounded in accordance with 250.110, 250.112, and 250.114.

440.62 Branch-Circuit Requirements.

(A) Room Air Conditioner as a Single Motor Unit. A room air conditioner shall be considered as a single motor unit in determining its branch-circuit requirements where all the following conditions are met:

- (1) It is cord-and-attachment-plug-connected.
- (2) Its rating is not more than 40 amperes and 250 volts, single phase.

- (3) Total rated-load current is shown on the room air-conditioner nameplate rather than individual motor currents.
- (4) The rating of the branch-circuit short-circuit and ground-fault protective device does not exceed the ampacity of the branch-circuit conductors or the rating of the receptacle, whichever is less.

(B) Where No Other Loads Are Supplied. The total marked rating of a cord-and-attachment-plug-connected room air conditioner shall not exceed 80 percent of the rating of a branch circuit where no other loads are supplied.

(C) Where Lighting Units or Other Appliances Are Also Supplied. The total marked rating of a cord-and-attachment-plug-connected room air conditioner shall not exceed 50 percent of the rating of a branch circuit where lighting outlets, other appliances, or general-use receptacles are also supplied. Where the circuitry is interlocked to prevent simultaneous operation of the room air conditioner and energization of other outlets on the same branch circuit, a cord-and-attachment-plug-connected room air conditioner shall not exceed 80 percent of the branch-circuit rating.

440.63 Disconnecting Means. An attachment plug and receptacle shall be permitted to serve as the disconnecting means for a single-phase room air conditioner rated 250 volts or less if (1) the manual controls on the room air conditioner are readily accessible and located within 1.8 m (6 ft) of the floor or (2) an approved manually operable disconnecting means is installed in a readily accessible location within sight from the room air conditioner.

440.64 Supply Cords. Where a flexible cord is used to supply a room air conditioner, the length of such cord shall not exceed 3.0 m (10 ft) for a nominal, 120-volt rating or 1.8 m (6 ft) for a nominal, 208- or 240-volt rating.

440.65 Leakage Current Detection and Interruption (LCDI) and Arc Fault Circuit Interrupter (AFCI). Single-phase cord-and-plug-connected room air conditioners shall be provided with factory-installed LCDI or AFCI protection. The LCDI or AFCI protection shall be an integral part of the attachment plug or be located in the power supply cord within 300 mm (12 in.) of the attachment plug.

ARTICLE 445 Generators

Installations shall conform to the requirements of Article 445 of the 2005 *National Electrical Code* (NFPA 70-2005).

Chapter 5 Special Occupancies

ARTICLE 550 Mobile Homes, Manufactured Homes, and Mobile Home Parks

I. General

550.1 Scope. The provisions of this article cover the electrical conductors and equipment installed within or on mobile and manufactured homes, the conductors that connect mobile and manufactured homes to a supply of electricity, and the installation of electrical wiring, luminaires (fixtures), equipment, and appurtenances related to electrical installations within a mobile home park up to the mobile home service-entrance conductors or, if none, the mobile home service equipment.

FPN: For additional information on manufactured housing see NFPA 501-2003, *Standard on Manufactured Housing*, and Part 3280, *Manufactured Home Construction and Safety Standards*, of the Federal Department of Housing and Urban Development.

550.2 Definitions.

Feeder Assembly. The overhead or under-chassis feeder conductors, including the grounding conductor, together with the necessary fittings and equipment or a power-supply cord listed for mobile home use, designed for the purpose of delivering energy from the source of electrical supply to the distribution panelboard within the mobile home.

Manufactured Home. A structure, transportable in one or more sections, that is 2.5 m (8 body ft) or more in width or 12 m (40 body ft) or more in length in the traveling mode or, when erected on site, is 30 m² (320 ft²) or more; which is built on a chassis and designed to be used as a dwelling, with or without a permanent foundation, when connected to the required utilities, including the plumbing, heating, air conditioning, and electrical systems contained therein. Calculations used to determine the number of square meters (square feet) in a structure will be based on the structure's exterior dimensions, measured at the largest horizontal projections when erected on site. These dimensions include all expandable rooms, cabinets, and other projections containing interior space but do not include inside bay windows.

For the purpose of this *Code* and unless otherwise indicated, the term mobile home includes manufactured homes.

FPN No. 1: See the applicable building code for definition of the term permanent foundation.

FPN No. 2: See Part 3280, *Manufactured Home Construction and Safety Standards*, of the Federal Department of Housing and Urban Development, for additional information on the definition.

Mobile Home. A factory-assembled structure or structures transportable in one or more sections that is built on a permanent chassis and designed to be used as a dwelling without a permanent foundation where connected to the required utilities and that includes the plumbing, heating, air-conditioning, and electric systems contained therein.

For the purpose of this *Code* and unless otherwise indicated, the term mobile home includes manufactured homes.

Mobile Home Accessory Building or Structure. Any awning, cabana, ramada, storage cabinet, carport, fence, windbreak, or porch established for the use of the occupant of the mobile home on a mobile home lot.

Mobile Home Lot. A designated portion of a mobile home park designed for the accommodation of one mobile home and its accessory buildings or structures for the exclusive use of its occupants.

Mobile Home Park. A contiguous parcel of land that is used for the accommodation of occupied mobile homes.

Mobile Home Service Equipment. The equipment containing the disconnecting means, overcurrent protective devices, and receptacles or other means for connecting a mobile home feeder assembly.

550.4 General Requirements.

(B) In Other Than Mobile Home Parks. Mobile homes installed in other than mobile home parks shall comply with the provisions of this article.

(C) Connection to Wiring System. The provisions of this article shall apply to mobile homes intended for connection to a wiring system rated 120/240 volts, nominal, 3-wire ac, with grounded neutral.

(D) Listed or Labeled. All electrical materials, devices, appliances, fittings, and other equipment shall be listed or labeled by a qualified testing agency and shall be connected in an approved manner when installed.

III. Services and Feeders

550.30 Distribution System. The mobile home park secondary electrical distribution system to mobile home lots shall be single-phase, 120/240 volts, nominal. For the purpose of Part III, where the park service exceeds 240 volts,

nominal, transformers and secondary distribution panels shall be treated as services.

550.31 Allowable Demand Factors. Park electrical wiring systems shall be calculated (at 120/240 volts) on the larger of the following:

- (1) 16,000 volt-amperes for each mobile home lot
- (2) The load calculated in accordance with 550.18 in the *NEC* for the largest typical mobile home that each lot will accept

It shall be permissible to calculate the feeder or service load in accordance with Table 550.31. No demand factor shall be allowed for any other load, except as provided in the *NEC*.

Service and feeder conductors to a mobile home in compliance with 310.15(B)(6) shall be permitted.

Table 550.31 Demand Factors for Services and Feeders

Number of Mobile Homes	Demand Factor (percent)
1	100
2	55
3	44
4	39
5	33
6	29
7-9	28
10-12	27
13-15	26
16-21	25
22-40	24
41-60	23
61 and over	22

550.32 Service Equipment.

(A) Mobile Home Service Equipment. The mobile home service equipment shall be located adjacent to the mobile home and not mounted in or on the mobile home. The service equipment shall be located in sight from and not more than 9.0 m (30 ft) from the exterior wall of the mobile home it serves. The service equipment shall be permitted to be located elsewhere on the premises, provided that a disconnecting means suitable for use as service equipment is located within sight from and not more than 9.0 m (30 ft) from the exterior wall of the mobile home it serves and is rated not less than that required for service equipment per 550.32(C). Grounding at the disconnecting means shall be in accordance with 250.32.

(B) Manufactured Home Service Equipment. The manufactured home service equipment shall be permitted to be

installed in or on a manufactured home, provided that all of the following conditions are met:

- (1) The manufacturer shall include in its written installation instructions information indicating that the home shall be secured in place by an anchoring system or installed on and secured to a permanent foundation.
- (2) The installation of the service equipment shall comply with Article 230.
- (3) Means shall be provided for the connection of a grounding electrode conductor to the service equipment and routing it outside the structure.
- (4) Bonding and grounding of the service shall be in accordance with Article 250.
- (5) The manufacturer shall include in its written installation instructions one method of grounding the service equipment at the installation site. The instructions shall clearly state that other methods of grounding are found in Article 250.
- (6) The minimum size grounding electrode conductor shall be specified in the instructions.
- (7) A red warning label shall be mounted on or adjacent to the service equipment. The label shall state the following:

WARNING
DO NOT PROVIDE ELECTRICAL POWER
UNTIL THE GROUNDING ELECTRODE(S)
IS INSTALLED AND CONNECTED
(SEE INSTALLATION INSTRUCTIONS).

Where the service equipment is not installed in or on the unit, the installation shall comply with the other provisions of this section.

(C) Rating. Mobile home service equipment shall be rated at not less than 100 amperes at 120/240 volts, and provisions shall be made for connecting a mobile home feeder assembly by a permanent wiring method. Power outlets used as mobile home service equipment shall also be permitted to contain receptacles rated up to 50 amperes with appropriate overcurrent protection. Fifty-ampere receptacles shall conform to the configuration shown in Figure 550.10(C) in the *NEC*.

FPN: Complete details of the 50-ampere plug and receptacle configuration can be found in ANSI/NEMA WD 6-1989, National Electrical Manufacturers Association *Standard for Wiring Devices — Dimensional Requirements*, Figure 14-50.

(D) Additional Outside Electrical Equipment. Means for connecting a mobile home accessory building or structure or additional electrical equipment located outside a mobile home by a fixed wiring method shall be provided in either the mobile home service equipment or the local external disconnecting means permitted in 550.32(A).

(E) Additional Receptacles. Additional receptacles shall be permitted for connection of electrical equipment located outside the mobile home, and all such 125-volt, single-phase, 15- and 20-ampere receptacles shall be protected by a listed ground-fault circuit interrupter.

(F) Mounting Height. Outdoor mobile home disconnecting means shall be installed so the bottom of the enclosure containing the disconnecting means is not less than 600 mm (2 ft) above finished grade or working platform. The disconnecting means shall be installed so that the center of the grip of the operating handle, when in the highest position, is not more than 2.0 m (6 ft 7 in.) above the finished grade or working platform.

(G) Marking. Where a 125/250-volt receptacle is used in mobile home service equipment, the service equipment shall be marked as follows:

TURN DISCONNECTING SWITCH OR
CIRCUIT BREAKER OFF BEFORE INSERTING
OR REMOVING PLUG. PLUG MUST BE FULLY
INSERTED OR REMOVED.

The marking shall be located on the service equipment adjacent to the receptacle outlet.

550.33 Feeder.

(A) Feeder Conductors. Feeder conductors shall consist of either a listed cord, factory installed in accordance with 550.10(B) in the *NEC*, or a permanently installed feeder consisting of four insulated, color-coded conductors that shall be identified by the factory or field marking of the conductors in compliance with 310.12. Equipment grounding conductors shall not be identified by stripping the insulation.

Exception: Where a feeder is installed between service equipment and a disconnecting means as covered in 550.32(A), it shall be permitted to omit the equipment grounding conductor where the grounded circuit conductor is grounded at the disconnecting means as required in 250.32(B).

(B) Feeder Capacity. Mobile home and manufactured home lot feeder circuit conductors shall have a capacity not less than the loads supplied and shall be rated at not less than 100 amperes at 120/240 volts.

ARTICLE 590 Temporary Installations

590.1 Scope. The provisions of this article apply to temporary electrical power and lighting installations.

590.2 All Wiring Installations.

(A) Other Articles. Except as specifically modified in this article, all other requirements of this *Code* for permanent wiring shall apply to temporary wiring installations.

(B) Approval. Temporary wiring methods shall be acceptable only if approved based on the conditions of use and any special requirements of the temporary installation.

590.3 Time Constraints.

(A) During the Period of Construction. Temporary electrical power and lighting installations shall be permitted during the period of construction, remodeling, maintenance, repair, or demolition of buildings, structures, equipment, or similar activities.

(B) 90 Days. Temporary electrical power and lighting installations shall be permitted for a period not to exceed 90 days for holiday decorative lighting and similar purposes.

(C) Emergencies and Tests. Temporary electrical power and lighting installations shall be permitted during emergencies and for tests, experiments, and developmental work.

(D) Removal. Temporary wiring shall be removed immediately upon completion of construction or purpose for which the wiring was installed.

590.4 General.

(A) Services. Services shall be installed in conformance with Article 230.

(B) Feeders. Overcurrent protection shall be provided in accordance with 240.4 and 240.5 in the *NEC*. They shall originate in an approved distribution center. Conductors shall be permitted within cable assemblies or within multiconductor cords or cables of a type identified in Table 400.4 in the *NEC* for hard usage or extra-hard usage. For the purpose of this section, Type NM and Type NMC cables shall be permitted to be used in any dwelling, building, or structure without any height limitation or limitation by building construction type and without concealment within walls, floors, or ceilings.

Exception: Single insulated conductors shall be permitted where installed for the purpose(s) specified in 590.3(C), where accessible only to qualified persons.

(C) Branch Circuits. All branch circuits shall originate in an approved power outlet or panelboard. Conductors shall be permitted within cable assemblies or within multiconductor cord or cable of a type identified in Table 400.4 in the *NEC* for hard usage or extra-hard usage. Conductors shall be protected from overcurrent as provided in 240.4 and 240.5 in the *NEC*. For the purposes of this section, Type NM and Type NMC cables shall be permitted to be used in any

dwelling, building, or structure without any height limitation or limitation by building construction type and without concealment within walls, floors, or ceilings.

Exception: Branch circuits installed for the purposes specified in 590.3(B) or 590.3(C) shall be permitted to be run as single insulated conductors. Where the wiring is installed in accordance with 590.3(B), the voltage to ground shall not exceed 150 volts, the wiring shall not be subject to physical damage, and the conductors shall be supported on insulators at intervals of not more than 3.0 m (10 ft); or, for festoon lighting, the conductors shall be so arranged that excessive strain is not transmitted to the lampholders.

(D) Receptacles. All receptacles shall be of the grounding type. Unless installed in a continuous grounded metal raceway or metal-covered cable, all branch circuits shall contain a separate equipment grounding conductor, and all receptacles shall be electrically connected to the equipment grounding conductors. Receptacles on construction sites shall not be installed on branch circuits that supply temporary lighting. Receptacles shall not be connected to the same ungrounded conductor of multiwire circuits that supply temporary lighting.

(E) Disconnecting Means. Suitable disconnecting switches or plug connectors shall be installed to permit the disconnection of all ungrounded conductors of each temporary circuit. Multiwire branch circuits shall be provided with a means to disconnect simultaneously all ungrounded conductors at the power outlet or panelboard where the branch circuit originated. Approved handle ties shall be permitted.

(F) Lamp Protection. All lamps for general illumination shall be protected from accidental contact or breakage by a suitable fixture or lampholder with a guard.

Brass shell, paper-lined sockets, or other metal-cased sockets shall not be used unless the shell is grounded.

(G) Splices. On construction sites, a box shall not be required for splices or junction connections where the circuit conductors are multiconductor cord or cable assemblies, provided that the equipment grounding continuity is maintained with or without the box. See 110.14(B) and 400.9. A box, conduit body, or terminal fitting having a separately bushed hole for each conductor shall be used wherever a change is made to a conduit or tubing system or a metal-sheathed cable system.

(H) Protection from Accidental Damage. Flexible cords and cables shall be protected from accidental damage. Sharp corners and projections shall be avoided. Where passing through doorways or other pinch points, protection shall be provided to avoid damage.

(I) Termination(s) at Devices. Flexible cords and cables entering enclosures containing devices requiring termination

shall be secured to the box with fittings designed for the purpose.

(J) Support. Cable assemblies and flexible cords and cables shall be supported in place at intervals that ensure that they will be protected from physical damage. Support shall be in the form of staples, cable ties, straps, or similar type fittings installed so as not to cause damage. Vegetation shall not be used for support of overhead spans of branch circuits or feeders.

Exception: For holiday lighting in accordance with 590.3(B), where the conductors or cables are arranged with proper strain relief devices, tension take-up devices, or other approved means to avoid damage from the movement of the live vegetation, trees shall be permitted to be used for support of overhead spans of branch circuit conductors or cables.

590.5 Listing of Decorative Lighting. Decorative lighting used for holiday lighting and similar purposes, in accordance with 590.3(B), shall be listed.

590.6 Ground-Fault Protection for Personnel. Ground-fault protection for personnel for all temporary wiring installations shall be provided to comply with 590.6(A) and 590.6(B). This section shall apply only to temporary wiring installations used to supply temporary power to equipment used by personnel during construction, remodeling, maintenance, repair, or demolition of buildings, structures, equipment, or similar activities.

(A) Receptacle Outlets. All 125-volt, single-phase, 15-, 20-, and 30-ampere receptacle outlets that are not a part of the permanent wiring of the building or structure and that are in use by personnel shall have ground-fault circuit interrupter protection for personnel. If a receptacle(s) is installed or exists as part of the permanent wiring of the building or structure and is used for temporary electric power, ground-fault circuit-interrupter protection for personnel shall be provided. For the purposes of this section, cord sets or devices incorporating listed ground-fault circuit interrupter protection for personnel identified for portable use shall be permitted.

(B) Use of Other Outlets. Receptacles other than 125-volt, single-phase, 15-, 20-, and 30-ampere receptacles shall have protection in accordance with (B)(1) or the assured equipment grounding conductor program in accordance with (B)(2).

(1) GFCI Protection. Ground-fault circuit interrupter protection for personnel.

(2) Assured Equipment Grounding Conductor Program. A written assured equipment grounding conductor program continuously enforced at the site by one or more

designated persons to ensure that equipment grounding conductors for all cord sets, receptacles that are not a part of the permanent wiring of the building or structure, and equipment connected by cord and plug are installed and maintained in accordance with the applicable requirements of 250.114, 250.138, 406.3(C), and 590.4(D).

(a) The following tests shall be performed on all cord sets, receptacles that are not part of the permanent wiring of the building or structure, and cord-and-plug-connected equipment required to be grounded:

(1) All equipment grounding conductors shall be tested for continuity and shall be electrically continuous.

(2) Each receptacle and attachment plug shall be tested for correct attachment of the equipment grounding conductor. The equipment grounding conductor shall be connected to its proper terminal.

(3) All required tests shall be performed as follows:

- a. Before first use on site
- b. When there is evidence of damage
- c. Before equipment is returned to service following any repairs
- d. At intervals not exceeding 3 months

(b) The tests required in item (2)(a) shall be recorded and made available to the authority having jurisdiction.

Chapter 6 Special Equipment

ARTICLE 680 Swimming Pools, Fountains, and Similar Installations

I. General

680.1 Scope. The provisions of this article apply to the construction and installation of electrical wiring for and equipment in or adjacent to all swimming, wading, therapeutic, and decorative pools; fountains; hot tubs; spas; and hydromassage bathtubs, whether permanently installed or storable, and to metallic auxiliary equipment, such as pumps, filters, and similar equipment. The term body of water used throughout Part I applies to all bodies of water covered in this scope unless otherwise amended.

680.2 Definitions.

Cord-and-Plug-Connected Lighting Assembly. A lighting assembly consisting of a luminaire (lighting fixture) intended for installation in the wall of a spa, hot tub, or storable pool, and a cord-and-plug-connected transformer.

Dry-Niche Luminaire (Lighting Fixture). A luminaire (lighting fixture) intended for installation in the wall of a pool or fountain in a niche that is sealed against the entry of pool water.

Equipment, Fixed. Equipment that is fastened or otherwise secured at a specific location.

Equipment, Portable. Equipment that is actually moved or can easily be moved from one place to another in normal use.

Equipment, Stationary. Equipment that is not easily moved from one place to another in normal use.

Forming Shell. A structure designed to support a wet-niche luminaire (lighting fixture) assembly and intended for mounting in a pool or fountain structure.

Fountain. Fountains, ornamental pools, display pools, and reflection pools. The definition does not include drinking fountains.

Hydromassage Bathtub. A permanently installed bathtub equipped with a recirculating piping system, pump, and associated equipment. It is designed so it can accept, circulate, and discharge water upon each use.

Maximum Water Level. The highest level that water can reach before it spills out.

No-Niche Luminaire (Lighting Fixture). A luminaire (lighting fixture) intended for installation above or below the water without a niche.

Packaged Spa or Hot Tub Equipment Assembly. A factory-fabricated unit consisting of water-circulating, heating, and control equipment mounted on a common base, intended to operate a spa or hot tub. Equipment can include pumps, air blowers, heaters, lights, controls, sanitizer generators, and so forth.

Permanently Installed Swimming, Wading, and Therapeutic Pools. Those that are constructed in the ground or partially in the ground, and all others capable of holding water in a depth greater than 1.0 m (42 in.), and all pools installed inside of a building, regardless of water depth, whether or not served by electrical circuits of any nature.

Pool. Manufactured or field-constructed equipment designed to contain water on a permanent or semipermanent basis and used for swimming, wading, or other purposes.

Pool Cover, Electrically Operated. Motor-driven equipment designed to cover and uncover the water surface of a pool by means of a flexible sheet or rigid frame.

Self-Contained Spa or Hot Tub. Factory-fabricated unit consisting of a spa or hot tub vessel with all water-circulating, heating, and control equipment integral to the unit. Equipment can include pumps, air blowers, heaters, lights, controls, sanitizer generators, and so forth.

Spa or Hot Tub. A hydromassage pool, or tub for recreational or therapeutic use, not located in health care facilities, designed for immersion of users, and usually having a filter, heater, and motor-driven blower. It may be installed indoors or outdoors, on the ground or supporting structure, or in the ground or supporting structure. Generally, a spa or hot tub is not designed or intended to have its contents drained or discharged after each use.

Storable Swimming or Wading Pool. Those that are constructed on or above the ground and are capable of holding water to a maximum depth of 1.0 m (42 in.), or a pool with nonmetallic, molded polymeric walls or inflatable fabric walls regardless of dimension.

Through-Wall Lighting Assembly. A lighting assembly intended for installation above grade, on or through the wall of a pool, consisting of two interconnected groups of components separated by the pool wall.

Wet-Niche Luminaire (Lighting Fixture). A luminaire (lighting fixture) intended for installation in a forming shell mounted in a pool or fountain structure where the luminaire (fixture) will be completely surrounded by water.

680.3 Other Articles. Except as modified by this article, wiring and equipment in or adjacent to pools and fountains shall comply with other applicable provisions of this *Code*, including those provisions identified in Table 680.3.

Table 680.3 Other Articles

Topic	Section or Article
Wiring	Chapters 1–4
Junction box support	314.23
Rigid nonmetallic conduit	352.12
Audio Equipment	Article 640, Parts I and II
Adjacent to pools and fountains	640.10
Underwater speakers*	

*Underwater loudspeakers shall be installed in accordance with 680.27(A).

680.4 Approval of Equipment. All electrical equipment installed in the water, walls, or decks of pools, fountains, and similar installations shall comply with the provisions of this article.

680.5 Ground-Fault Circuit Interrupters. Ground-fault circuit interrupters (GFCIs) shall be self-contained units, circuit-breaker or receptacle types, or other listed types.

680.6 Grounding. Electrical equipment shall be grounded in accordance with Parts V, VI, and VII of Article 250 and connected by wiring methods of Chapter 3, except as modified by this article. The following equipment shall be grounded:

- (1) Through-wall lighting assemblies and underwater luminaires (lighting fixtures), other than those low-voltage systems listed for the application without a grounding conductor
- (2) All electrical equipment located within 1.5 m (5 ft) of the inside wall of the specified body of water
- (3) All electrical equipment associated with the recirculating system of the specified body of water
- (4) Junction boxes
- (5) Transformer enclosures
- (6) Ground-fault circuit interrupters
- (7) Panelboards that are not part of the service equipment and that supply any electrical equipment associated with the specified body of water

680.7 Cord-and-Plug-Connected Equipment. Fixed or stationary equipment other than an underwater luminaire (lighting fixture) for a permanently installed pool shall be permitted to be connected with a flexible cord to facilitate the removal or disconnection for maintenance or repair.

(A) Length. For other than storable pools, the flexible cord shall not exceed 900 mm (3 ft) in length.

(B) Equipment Grounding. The flexible cord shall have a copper equipment grounding conductor sized in accordance with 250.122 but not smaller than 12 AWG. The cord shall terminate in a grounding-type attachment plug.

(C) Construction. The equipment grounding conductors shall be connected to a fixed metal part of the assembly. The removable part shall be mounted on or bonded to the fixed metal part.

680.8 Overhead Conductor Clearances. Overhead conductors shall meet the clearance requirements in this section. Where a minimum clearance from the water level is given, the measurement shall be taken from the maximum water level of the specified body of water.

(A) Power. With respect to service drop conductors and open overhead wiring, swimming pool and similar installations shall comply with the minimum clearances given in Table 680.8 and illustrated in Figure 680.8.

FPN: Open overhead wiring as used in this article typically refers to conductor(s) not in an enclosed raceway.

(B) Communications Systems. Communication, radio, and television coaxial cables within the scope of Articles 800, 820, and 810 in the *NEC* shall be permitted at a height of not less than 3.0 m (10 ft) above swimming and wading pools, diving structures, and observation stands, towers, or platforms.

(C) Network-Powered Broadband Communications Systems. The minimum clearances for overhead network-powered broadband communications systems conductors from pools or fountains shall comply with the provisions in Table 680.8 for conductors operating at 0 to 750 volts to ground.

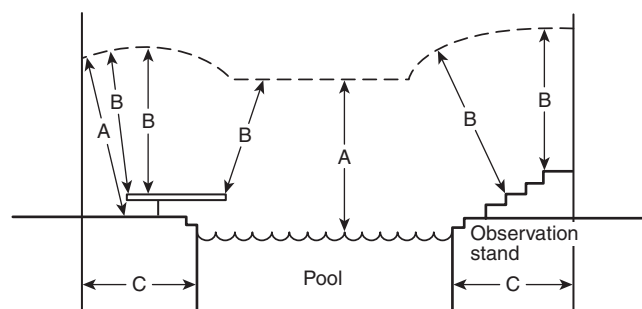

Figure 680.8 Clearances from Pool Structures.

Table 680.8 Overhead Conductor Clearances

Clearance Parameters	Insulated Cables, 0-750 Volts to Ground, Supported on and Cabled Together with an Effectively Grounded Bare Messenger or Effectively Grounded Neutral Conductor		All Other Conductors Voltage to Ground			
	m	ft	0 through 15 kV		Over 15 through 50 kV	
			m	ft	m	ft
A. Clearance in any direction to the water level, edge of water surface, base of diving platform, or permanently anchored raft	6.9	22.5	7.5	25	8.0	27
B. Clearance in any direction to the observation stand, tower, or diving platform	4.4	14.5	5.2	17	5.5	18
C. Horizontal limit of clearance measured from inside wall of the pool	This limit shall extend to the outer edge of the structures listed in A and B of this table but not to less than 3 m (10 ft).					

680.9 Electric Pool Water Heaters. All electric pool water heaters shall have the heating elements subdivided into loads not exceeding 48 amperes and protected at not over 60 amperes. The ampacity of the branch-circuit conductors and the rating or setting of overcurrent protective devices shall not be less than 125 percent of the total nameplate-rated load.

680.10 Underground Wiring Location. Underground wiring shall not be permitted under the pool or within the area extending 1.5 m (5 ft) horizontally from the inside wall of the pool unless this wiring is necessary to supply pool equipment permitted by this article. Where space limitations prevent wiring from being routed a distance 1.5 m (5 ft) or more from the pool, such wiring shall be permitted where installed in rigid metal conduit, intermediate metal conduit, or a nonmetallic raceway system. All metal conduit shall be corrosion resistant and suitable for the location. The minimum burial depth shall be as given in Table 680.10.

680.11 Equipment Rooms and Pits. Electric equipment shall not be installed in rooms or pits that do not have drainage that adequately prevents water accumulation during normal operation or filter maintenance.

680.12 Maintenance Disconnecting Means. One or more means to disconnect all ungrounded conductors shall be provided for all utilization equipment other than lighting. Each means shall be readily accessible and within sight from its equipment.

Table 680.10 Minimum Burial Depths

Wiring Method	Minimum Burial	
	mm	in.
Rigid metal conduit	150	6
Intermediate metal conduit	150	6
Nonmetallic raceways listed for direct burial without concrete encasement	450	18
Other approved raceways*	450	18

*Raceways approved for burial only where concrete encased shall require a concrete envelope not less than 50 mm (2 in.) thick.

II. Permanently Installed Pools

680.20 General. Electrical installations at permanently installed pools shall comply with the provisions of Part I and Part II of this article.

680.21 Motors.

(A) Wiring Methods.

(1) General. The branch circuits for pool-associated motors shall be installed in rigid metal conduit, intermediate metal conduit, rigid nonmetallic conduit, or Type MC cable listed for the location. Other wiring methods and materials shall be permitted in specific locations or applications as covered in this section. Any wiring method employed shall contain an insulated copper equipment grounding conductor

sized in accordance with 250.122 but not smaller than 12 AWG.

(2) On or Within Buildings. Where installed on or within buildings, electrical metallic tubing shall be permitted.

(3) Flexible Connections. Where necessary to employ flexible connections at or adjacent to the motor, liquidtight flexible metal or nonmetallic conduit with approved fittings shall be permitted.

(4) One-Family Dwellings. In the interior of one-family dwellings, or in the interior of accessory buildings associated with a one-family dwelling, any of the wiring methods recognized in Chapter 3 of this *Code* that comply with the provisions of this paragraph shall be permitted. Where run in a cable assembly, the equipment grounding conductor shall be permitted to be uninsulated, but it shall be enclosed within the outer sheath of the cable assembly.

(5) Cord-and-Plug Connections. Pool-associated motors shall be permitted to employ cord-and-plug connections. The flexible cord shall not exceed 900 mm (3 ft) in length. The flexible cord shall include an equipment grounding conductor sized in accordance with 250.122 and shall terminate in a grounding-type attachment plug.

(B) Double Insulated Pool Pumps. A listed cord-and-plug-connected pool pump incorporating an approved system of double insulation that provides a means for grounding only the internal and nonaccessible, non-current-carrying metal parts of the pump shall be connected to any wiring method recognized in Chapter 3 that is suitable for the location. Where the bonding grid is connected to the equipment grounding conductor of the motor circuit in accordance with the second paragraph of 680.26(B)(4), the branch circuit wiring shall comply with 680.21(A).

680.22 Area Lighting, Receptacles, and Equipment.

(A) Receptacles.

(1) Circulation and Sanitation System, Location. Receptacles that provide power for water-pump motors or for other loads directly related to the circulation and sanitation system shall be located at least 3.0 m (10 ft) from the inside walls of the pool, or not less than 1.5 m (5 ft) from the inside walls of the pool if they meet all of the following conditions:

- (1) Consist of single receptacles
- (2) Employ a locking configuration
- (3) Are of the grounding type
- (4) Have GFCI protection

(2) Other Receptacles, Location. Other receptacles shall be not less than 3.0 m (10 ft) from the inside walls of a pool.

(3) Dwelling Unit(s). Where a permanently installed pool is installed at a dwelling unit(s), no fewer than one 125-volt 15- or 20-ampere receptacle on a general-purpose branch circuit shall be located not less than 3.0 m (10 ft) from, and not more than 6.0 m (20 ft) from, the inside wall of the pool. This receptacle shall be located not more than 2.0 m (6 ft 6 in.) above the floor, platform, or grade level serving the pool.

(4) Restricted Space. Where a pool is within 3.0 m (10 ft) of a dwelling and the dimensions of the lot preclude meeting the required clearances, not more than one receptacle outlet shall be permitted if not less than 1.5 m (5 ft) measured horizontally from the inside wall of the pool.

(5) GFCI Protection. All 15- and 20-ampere, single-phase, 125-volt receptacles located within 6.0 m (20 ft) of the inside walls of a pool shall be protected by a ground-fault circuit interrupter. Receptacles that supply pool pump motors and that are rated 15 or 20 amperes, 125 volts through 250 volts, single phase, shall be provided with GFCI protection.

(6) Measurements. In determining the dimensions in this section addressing receptacle spacings, the distance to be measured shall be the shortest path the supply cord of an appliance connected to the receptacle would follow without piercing a floor, wall, ceiling, doorway with hinged or sliding door, window opening, or other effective permanent barrier.

(B) Luminaires (Lighting Fixtures), Lighting Outlets, and Ceiling-Suspended (Paddle) Fans.

(1) New Outdoor Installation Clearances. In outdoor pool areas, luminaires (lighting fixtures), lighting outlets, and ceiling-suspended (paddle) fans installed above the pool or the area extending 1.5 m (5 ft) horizontally from the inside walls of the pool shall be installed at a height not less than 3.7 m (12 ft) above the maximum water level of the pool.

(2) Indoor Clearances. For installations in indoor pool areas, the clearances shall be the same as for outdoor areas unless modified as provided in this paragraph. If the branch circuit supplying the equipment is protected by a ground-fault circuit interrupter, the following equipment shall be permitted at a height not less than 2.3 m (7 ft 6 in.) above the maximum pool water level:

- (1) Totally enclosed luminaires (fixtures)
- (2) Ceiling-suspended (paddle) fans identified for use beneath ceiling structures such as provided on porches or patios

(3) Existing Installations. Existing luminaires (lighting fixtures) and lighting outlets located less than 1.5 m (5 ft) measured horizontally from the inside walls of a pool shall

be not less than 1.5 m (5 ft) above the surface of the maximum water level, shall be rigidly attached to the existing structure, and shall be protected by a ground-fault circuit interrupter.

(4) GFCI Protection in Adjacent Areas. Luminaires (lighting fixtures), lighting outlets, and ceiling-suspended (paddle) fans installed in the area extending between 1.5 m (5 ft) and 3.0 m (10 ft) horizontally from the inside walls of a pool shall be protected by a ground-fault circuit interrupter unless installed not less than 1.5 m (5 ft) above the maximum water level and rigidly attached to the structure adjacent to or enclosing the pool.

(5) Cord-and-Plug-Connected Luminaires (Lighting Fixtures). Cord-and-plug-connected luminaires (lighting fixtures) shall comply with the requirements of 680.7 where installed within 4.9 m (16 ft) of any point on the water surface, measured radially.

(C) Switching Devices. Switching devices shall be located at least 1.5 m (5 ft) horizontally from the inside walls of a pool unless separated from the pool by a solid fence, wall, or other permanent barrier. Alternatively, a switch that is listed as being acceptable for use within 1.5 m (5 ft) shall be permitted.

680.23 Underwater Luminaires (Lighting Fixtures). This section covers all luminaires (lighting fixtures) installed below the normal water level of the pool.

(A) General.

(1) Luminaire (Fixture) Design, Normal Operation. The design of an underwater luminaire (lighting fixture) supplied from a branch circuit either directly or by way of a transformer meeting the requirements of this section shall be such that, where the luminaire (fixture) is properly installed without a ground-fault circuit interrupter, there is no shock hazard with any likely combination of fault conditions during normal use (not relamping).

(2) Transformers. Transformers used for the supply of underwater luminaires (fixtures), together with the transformer enclosure, shall be listed as a swimming pool and spa transformer. The transformer shall be an isolated winding type with an ungrounded secondary that has a grounded metal barrier between the primary and secondary windings.

(3) GFCI Protection, Relamping. A ground-fault circuit interrupter shall be installed in the branch circuit supplying luminaires (fixtures) operating at more than 15 volts such that there is no shock hazard during relamping. The installation of the ground-fault circuit interrupter shall be such that there is no shock hazard with any likely fault-condition combination that involves a person in a conductive path from

any ungrounded part of the branch circuit or the luminaire (fixture) to ground.

(4) Voltage Limitation. No luminaires (lighting fixtures) shall be installed for operation on supply circuits over 150 volts between conductors.

(5) Location, Wall-Mounted Luminaires (Fixtures). Luminaires (lighting fixtures) mounted in walls shall be installed with the top of the luminaire (fixture) lens not less than 450 mm (18 in.) below the normal water level of the pool, unless the luminaire (lighting fixture) is listed and identified for use at lesser depths. No luminaire (fixture) shall be installed less than 100 mm (4 in.) below the normal water level of the pool.

(6) Bottom-Mounted Luminaires (Fixtures). A luminaire (lighting fixture) facing upward shall have the lens adequately guarded to prevent contact by any person.

(7) Dependence on Submersion. Luminaires (fixtures) that depend on submersion for safe operation shall be inherently protected against the hazards of overheating when not submerged.

(8) Compliance. Compliance with these requirements shall be obtained by the use of a listed underwater luminaire (lighting fixture) and by installation of a listed ground-fault circuit interrupter in the branch circuit or a listed transformer for luminaires (fixtures) operating at not more than 15 volts.

(B) Wet-Niche Luminaires (Fixtures).

(1) Forming Shells. Forming shells shall be installed for the mounting of all wet-niche underwater luminaires (fixtures) and shall be equipped with provisions for conduit entries. Metal parts of the luminaire (fixture) and forming shell in contact with the pool water shall be of brass or other approved corrosion-resistant metal. All forming shells used with nonmetallic conduit systems, other than those that are part of a listed low-voltage lighting system not requiring grounding, shall include provisions for terminating an 8 AWG copper conductor.

(2) Wiring Extending Directly to the Forming Shell. Conduit shall be installed from the forming shell to a junction box or other enclosure conforming to the requirements in 680.24. Conduit shall be rigid metal, intermediate metal, liquidtight flexible nonmetallic, or rigid nonmetallic.

(a) Metal Conduit. Metal conduit shall be approved and shall be of brass or other approved corrosion-resistant metal.

(b) Nonmetallic Conduit. Where a nonmetallic conduit is used, an 8 AWG insulated solid or stranded copper bonding jumper shall be installed in this conduit unless a listed low-voltage lighting system not requiring grounding is used. The bonding jumper shall be terminated in the forming shell,

junction box or transformer enclosure, or ground-fault circuit-interrupter enclosure. The termination of the 8 AWG bonding jumper in the forming shell shall be covered with, or encapsulated in, a listed potting compound to protect the connection from the possible deteriorating effect of pool water.

(3) Equipment Grounding Provisions for Cords. Wet-niche luminaires (lighting fixtures) that are supplied by a flexible cord or cable shall have all exposed non-current-carrying metal parts grounded by an insulated copper equipment grounding conductor that is an integral part of the cord or cable. This grounding conductor shall be connected to a grounding terminal in the supply junction box, transformer enclosure, or other enclosure. The grounding conductor shall not be smaller than the supply conductors and not smaller than 16 AWG.

(4) Luminaire (Fixture) Grounding Terminations. The end of the flexible-cord jacket and the flexible-cord conductor terminations within a luminaire (fixture) shall be covered with, or encapsulated in, a suitable potting compound to prevent the entry of water into the luminaire (fixture) through the cord or its conductors. In addition, the grounding connection within a luminaire (fixture) shall be similarly treated to protect such connection from the deteriorating effect of pool water in the event of water entry into the luminaire (fixture).

(5) Luminaire (Fixture) Bonding. The luminaire (fixture) shall be bonded to and secured to the forming shell by a positive locking device that ensures a low-resistance contact and requires a tool to remove the luminaire (fixture) from the forming shell. Bonding shall not be required for luminaires (fixtures) that are listed for the application and have no non-current-carrying metal parts.

(6) Servicing. All luminaires shall be removable from the water for relamping or normal maintenance. Luminaires shall be installed in such a manner that personnel can reach the luminaire for relamping, maintenance, or inspection while on the deck or equivalently dry location.

(C) Dry-Niche Luminaires (Fixtures).

(1) Construction. A dry-niche luminaire (lighting fixture) shall be provided with a provision for drainage of water and a means for accommodating one equipment grounding conductor for each conduit entry.

(2) Junction Box. A junction box shall not be required but, if used, shall not be required to be elevated or located as specified in 680.24(A)(2) if the luminaire (fixture) is specifically identified for the purpose.

(D) No-Niche Luminaires (Fixtures). A no-niche luminaire (fixture) shall meet the construction requirements of

680.23(B)(3) and be installed in accordance with the requirements of 680.23(B). Where connection to a forming shell is specified, the connection shall be to the mounting bracket.

(E) Through-Wall Lighting Assembly. A through-wall lighting assembly shall be equipped with a threaded entry or hub, or a nonmetallic hub, for the purpose of accommodating the termination of the supply conduit. A through-wall lighting assembly shall meet the construction requirements of 680.23(B)(3) and be installed in accordance with the requirements of 680.23. Where connection to a forming shell is specified, the connection shall be to the conduit termination point.

(F) Branch-Circuit Wiring.

(1) Wiring Methods. Branch-circuit wiring on the supply side of enclosures and junction boxes connected to conduits run to wet-niche and no-niche luminaires (fixtures), and the field wiring compartments of dry-niche luminaires (fixtures), shall be installed using rigid metal conduit, intermediate metal conduit, liquidtight flexible nonmetallic conduit, or rigid nonmetallic conduit. Where installed on buildings, electrical metallic tubing shall be permitted, and where installed within buildings, electrical nonmetallic tubing, Type MC cable, or electrical metallic tubing shall be permitted.

Exception: Where connecting to transformers for pool lights, liquidtight flexible metal conduit or liquidtight flexible nonmetallic conduit shall be permitted. The length shall not exceed 1.8 m (6 ft) for any one length or exceed 3.0 m (10 ft) in total length used. Liquidtight flexible nonmetallic conduit, Type B (LFNC-B), shall be permitted in lengths longer than 1.8 m (6 ft).

(2) Equipment Grounding. Through-wall lighting assemblies, wet-niche, dry-niche, or no-niche luminaires (lighting fixtures) shall be connected to an insulated copper equipment grounding conductor installed with the circuit conductors. The equipment grounding conductor shall be installed without joint or splice except as permitted in (F)(2)(a) and (F)(2)(b). The equipment grounding conductor shall be sized in accordance with Table 250.122 but shall not be smaller than 12 AWG.

Exception: An equipment grounding conductor between the wiring chamber of the secondary winding of a transformer and a junction box shall be sized in accordance with the overcurrent device in this circuit.

(a) If more than one underwater luminaire (lighting fixture) is supplied by the same branch circuit, the equipment grounding conductor, installed between the junction boxes, transformer enclosures, or other enclosures in the supply circuit to wet-niche luminaires (fixtures), or between the field-wiring compartments of dry-niche luminaires (fix-

tures), shall be permitted to be terminated on grounding terminals.

(b) If the underwater luminaire (lighting fixture) is supplied from a transformer, ground-fault circuit interrupter, clock-operated switch, or a manual snap switch that is located between the panelboard and a junction box connected to the conduit that extends directly to the underwater luminaire (lighting fixture), the equipment grounding conductor shall be permitted to terminate on grounding terminals on the transformer, ground-fault circuit interrupter, clock-operated switch enclosure, or an outlet box used to enclose a snap switch.

(3) Conductors. Conductors on the load side of a ground-fault circuit interrupter or of a transformer, used to comply with the provisions of 680.23(A)(8), shall not occupy raceways, boxes, or enclosures containing other conductors unless one of the following conditions applies:

- (1) The other conductors are protected by ground-fault circuit interrupters.
- (2) The other conductors are grounding conductors.
- (3) The other conductors are supply conductors to a feed-through type ground-fault circuit interrupter.
- (4) Ground-fault circuit interrupters shall be permitted in a panelboard that contains circuits protected by other than ground-fault circuit interrupters.

680.24 Junction Boxes and Enclosures for Transformers or Ground-Fault Circuit Interrupters.

(A) Junction Boxes. A junction box connected to a conduit that extends directly to a forming shell or mounting bracket of a no-niche luminaire (fixture) shall meet the requirements of this section.

(1) Construction. The junction box shall be listed as a swimming pool junction box and shall comply with the following conditions:

- (1) Be equipped with threaded entries or hubs or a nonmetallic hub
- (2) Be comprised of copper, brass, suitable plastic, or other approved corrosion-resistant material
- (3) Be provided with electrical continuity between every connected metal conduit and the grounding terminals by means of copper, brass, or other approved corrosion-resistant metal that is integral with the box

(2) Installation. Where the luminaire (fixture) operates over 15 volts, the junction box location shall comply with (A)(2)(a) and (A)(2)(b). Where the luminaire (fixture) operates at less than 15 volts, the junction box location shall be permitted to comply with (A)(2)(c).

(a) Vertical Spacing. The junction box shall be located not less than 100 mm (4 in.), measured from the inside of

the bottom of the box, above the ground level, or pool deck, or not less than 200 mm (8 in.) above the maximum pool water level, whichever provides the greater elevation.

(b) Horizontal Spacing. The junction box shall be located not less than 1.2 m (4 ft) from the inside wall of the pool, unless separated from the pool by a solid fence, wall, or other permanent barrier.

(c) Flush Deck Box. If used on a lighting system operating at 15 volts or less, a flush deck box shall be permitted if both of the following apply:

- (1) An approved potting compound is used to fill the box to prevent the entrance of moisture.
- (2) The flush deck box is located not less than 1.2 m (4 ft) from the inside wall of the pool.

(B) Other Enclosures. An enclosure for a transformer, ground-fault circuit interrupter, or a similar device connected to a conduit that extends directly to a forming shell or mounting bracket of a no-niche luminaire (fixture) shall meet the requirements of this section.

(1) Construction. The enclosure shall be listed and labeled for the purpose and meet the following requirements:

- (1) Equipped with threaded entries or hubs or a nonmetallic hub
- (2) Comprised of copper, brass, suitable plastic, or other approved corrosion-resistant material
- (3) Provided with an approved seal, such as duct seal at the conduit connection, that prevents circulation of air between the conduit and the enclosures
- (4) Provided with electrical continuity between every connected metal conduit and the grounding terminals by means of copper, brass, or other approved corrosion-resistant metal that is integral with the box

(2) Installation.

(a) Vertical Spacing. The enclosure shall be located not less than 100 mm (4 in.), measured from the inside of the bottom of the box, above the ground level, or pool deck, or not less than 200 mm (8 in.) above the maximum pool water level, whichever provides the greater elevation.

(b) Horizontal Spacing. The enclosure shall be located not less than 1.2 m (4 ft) from the inside wall of the pool, unless separated from the pool by a solid fence, wall, or other permanent barrier.

(C) Protection. Junction boxes and enclosures mounted above the grade of the finished walkway around the pool shall not be located in the walkway unless afforded additional protection, such as by location under diving boards, adjacent to fixed structures, and the like.

(D) Grounding Terminals. Junction boxes, transformer enclosures, and ground-fault circuit-interrupter enclosures

connected to a conduit that extends directly to a forming shell or mounting bracket of a no-niche luminaire (fixture) shall be provided with a number of grounding terminals that shall be no fewer than one more than the number of conduit entries.

(E) Strain Relief. The termination of a flexible cord of an underwater luminaire (lighting fixture) within a junction box, transformer enclosure, ground-fault circuit interrupter, or other enclosure shall be provided with a strain relief.

(F) Grounding. The junction box, transformer enclosure, or other enclosure in the supply circuit to a wet-niche or no-niche luminaire (lighting fixture) and the field-wiring chamber of a dry-niche luminaire (lighting fixture) shall be grounded to the equipment grounding terminal of the panelboard. This terminal shall be directly connected to the panelboard enclosure.

680.25 Feeders. These provisions shall apply to any feeder on the supply side of panelboards supplying branch circuits for pool equipment covered in Part II of this article and on the load side of the service equipment or the source of a separately derived system.

(A) Wiring Methods. Feeders shall be installed in rigid metal conduit, intermediate metal conduit, liquidtight flexible nonmetallic conduit, or rigid nonmetallic conduit. Electrical metallic tubing shall be permitted where installed on or within a building, and electrical nonmetallic tubing shall be permitted where installed within a building.

Exception: An existing feeder between an existing remote panelboard and service equipment shall be permitted to run in flexible metal conduit or an approved cable assembly that includes an equipment grounding conductor within its outer sheath. The equipment grounding conductor shall comply with 250.24(A)(5).

(B) Grounding. An equipment grounding conductor shall be installed with the feeder conductors between the grounding terminal of the pool equipment panelboard and the grounding terminal of the applicable service equipment or source of a separately derived system. For other than (1) existing feeders covered in 680.25(A), Exception, or (2) feeders to separate buildings that do not utilize an insulated equipment grounding conductor in accordance with 680.25(B)(2), this equipment grounding conductor shall be insulated.

(1) Size. This conductor shall be sized in accordance with 250.122 but not smaller than 12 AWG. On separately derived systems, this conductor shall be sized in accordance with Table 250.66 but not smaller than 8 AWG.

(2) Separate Buildings. A feeder to a separate building or structure shall be permitted to supply swimming pool

equipment branch circuits, or feeders supplying swimming pool equipment branch circuits, if the grounding arrangements in the separate building meet the requirements in 250.32(B)(1). Where installed in other than existing feeders covered in 680.25(A), Exception, a separate equipment grounding conductor shall be an insulated conductor.

680.26 Equipotential Bonding.

(A) Performance. The equipotential bonding required by this section shall be installed to eliminate voltage gradients in the pool area as prescribed.

FPN: The 8 AWG or larger solid copper bonding conductor shall not be required to be extended or attached to any remote panelboard, service equipment, or any electrode.

(B) Bonded Parts. The parts specified in 680.26(B)(1) through (B)(5) shall be bonded together.

(1) Metallic Structural Components. All metallic parts of the pool structure, including the reinforcing metal of the pool shell, coping stones, and deck, shall be bonded. The usual steel tie wires shall be considered suitable for bonding the reinforcing steel together, and welding or special clamping shall not be required. These tie wires shall be made tight. If reinforcing steel is effectively insulated by an encapsulating nonconductive compound at the time of manufacture and installation, it shall not be required to be bonded. Where reinforcing steel of the pool shell or the reinforcing steel of coping stones and deck is encapsulated with a nonconductive compound or another conductive material is not available, provisions shall be made for an alternative means to eliminate voltage gradients that would otherwise be provided by unencapsulated, bonded reinforcing steel.

(2) Underwater Lighting. All metal forming shells and mounting brackets of no-niche luminaires (fixtures) shall be bonded unless a listed low-voltage lighting system with nonmetallic forming shells not requiring bonding is used.

(3) Metal Fittings. All metal fittings within or attached to the pool structure shall be bonded. Isolated parts that are not over 100 mm (4 in.) in any dimension and do not penetrate into the pool structure more than 25 mm (1 in.) shall not require bonding.

(4) Electrical Equipment. Metal parts of electrical equipment associated with the pool water circulating system, including pump motors and metal parts of equipment associated with pool covers, including electric motors, shall be bonded. Accessible metal parts of listed equipment incorporating an approved system of double insulation and providing a means for grounding internal nonaccessible, non-current-carrying metal parts shall not be bonded by a direct connection to the equipotential bonding grid. The means for grounding internal nonaccessible, non-current

carrying metal parts shall be an equipment grounding conductor run with the power-supply conductors in the case of motors supplied with a flexible cord, or a grounding terminal in the case of motors intended for permanent connection.

Where a double-insulated water-pump motor is installed under the provisions of this rule, a solid 8 AWG copper conductor that is of sufficient length to make a bonding connection to a replacement motor shall be extended from the bonding grid to an accessible point in the motor vicinity. Where there is no connection between the swimming pool bonding grid and the equipment grounding system for the premises, this bonding conductor shall be connected to the equipment grounding conductor of the motor circuit.

(5) Metal Wiring Methods and Equipment. Metal-sheathed cables and raceways, metal piping, and all fixed metal parts that are within the following distances of the pool, except those separated from the pool by a permanent barrier, shall be bonded.

- (1) Within 1.5 m (5 ft) horizontally of the inside walls of the pool
- (2) Within 3.7 m (12 ft) measured vertically above the maximum water level of the pool, or any observation stands, towers, or platforms, or any diving structures

(C) Equipotential Bonding Grid. The parts specified in 680.26(B) shall be connected to an equipotential bonding grid with a solid copper conductor, insulated, covered, or bare, not smaller than 8 AWG or rigid metal conduit of brass or other identified corrosion-resistant metal conduit. Connection shall be made by exothermic welding or by listed pressure connectors or clamps that are labeled as being suitable for the purpose and are of stainless steel, brass, copper, or copper alloy. The equipotential bonding grid shall extend under paved walking surfaces for 1 m (3 ft) horizontally beyond the inside walls of the pool and shall be permitted to be any of the following:

- (1) **Structural Reinforcing Steel.** The structural reinforcing steel of a concrete pool where the reinforcing rods are bonded together by the usual steel tie wires or the equivalent
- (2) **Bolted or Welded Metal Pools.** The wall of a bolted or welded metal pool
- (3) **Alternate Means.** This system shall be permitted to be constructed as specified in (a) through (c):
 - a. **Materials and Connections.** The grid shall be constructed of minimum 8 AWG bare solid copper conductors. Conductors shall be bonded to each other at all points of crossing. Connections shall be made as required by 680.26(D).
 - b. **Grid Structure.** The equipotential bonding grid shall cover the contour of the pool and the pool deck

extending 1 m (3 ft) horizontally from the inside walls of the pool. The equipotential bonding grid shall be arranged in a 300 mm (12 in.) by 300 mm (12 in.) network of conductors in a uniformly spaced perpendicular grid pattern with tolerance of 100 mm (4 in.).

- c. **Securing.** The below-grade grid shall be secured within or under the pool and deck media.

(D) Connections. Where structural reinforcing steel or the walls of bolted or welded metal pool structures are used as an equipotential bonding grid for nonelectrical parts, the connections shall be made in accordance with 250.8.

(E) Pool Water Heaters. For pool water heaters rated at more than 50 amperes and having specific instructions regarding bonding and grounding, only those parts designated to be bonded shall be bonded and only those parts designated to be grounded shall be grounded.

680.27 Specialized Pool Equipment.

(A) Underwater Audio Equipment. All underwater audio equipment shall be identified for the purpose.

(1) Speakers. Each speaker shall be mounted in an approved metal forming shell, the front of which is enclosed by a captive metal screen, or equivalent, that is bonded to, and secured to, the forming shell by a positive locking device that ensures a low-resistance contact and requires a tool to open for installation or servicing of the speaker. The forming shell shall be installed in a recess in the wall or floor of the pool.

(2) Wiring Methods. Rigid metal conduit or intermediate metal conduit of brass or other identified corrosion-resistant metal, liquidtight flexible nonmetallic conduit (LFNC-B), or rigid nonmetallic conduit shall extend from the forming shell to a listed junction box or other enclosure as provided in 680.24. Where rigid nonmetallic conduit or liquidtight flexible nonmetallic conduit is used, an 8 AWG insulated solid or stranded copper bonding jumper shall be installed in this conduit. The bonding jumper shall be terminated in the forming shell and the junction box. The termination of the 8 AWG bonding jumper in the forming shell shall be covered with, or encapsulated in, a listed potting compound to protect such connection from the possible deteriorating effect of pool water.

(3) Forming Shell and Metal Screen. The forming shell and metal screen shall be of brass or other approved corrosion-resistant metal. All forming shells shall include provisions for terminating an 8 AWG copper conductor.

(B) Electrically Operated Pool Covers.

(1) Motors and Controllers. The electric motors, controllers, and wiring shall be located not less than 1.5 m (5 ft)

from the inside wall of the pool unless separated from the pool by a wall, cover, or other permanent barrier. Electric motors installed below grade level shall be of the totally enclosed type. The device that controls the operation of the motor for an electrically operated pool cover shall be located such that the operator has full view of the pool.

FPN No. 1: For cabinets installed in damp and wet locations, see 312.2(A).

FPN No. 2: For switches or circuit breakers installed in wet locations, see 404.4.

FPN No. 3: For protection against liquids, see 430.11 in the *NEC*.

(2) Protection. The electric motor and controller shall be connected to a circuit protected by a ground-fault circuit interrupter.

(C) Deck Area Heating. These provisions of this section shall apply to all pool deck areas, including a covered pool, where electrically operated comfort heating units are installed within 6.0 m (20 ft) of the inside wall of the pool.

(1) Unit Heaters. Unit heaters shall be rigidly mounted to the structure and shall be of the totally enclosed or guarded types. Unit heaters shall not be mounted over the pool or within the area extending 1.5 m (5 ft) horizontally from the inside walls of a pool.

(2) Permanently Wired Radiant Heaters. Radiant electric heaters shall be suitably guarded and securely fastened to their mounting device(s). Heaters shall not be installed over a pool or within the area extending 1.5 m (5 ft) horizontally from the inside walls of the pool and shall be mounted at least 3.7 m (12 ft) vertically above the pool deck unless otherwise approved.

(3) Radiant Heating Cables Not Permitted. Radiant heating cables embedded in or below the deck shall not be permitted.

III. Storable Pools

680.30 General. Electrical installations at storable pools shall comply with the provisions of Part I and Part III of this article.

680.31 Pumps. A cord-connected pool filter pump shall incorporate an approved system of double insulation or its equivalent and shall be provided with means for grounding only the internal and nonaccessible non-current-carrying metal parts of the appliance.

The means for grounding shall be an equipment ground-conductor run with the power-supply conductors in the

flexible cord that is properly terminated in a grounding-type attachment plug having a fixed grounding contact member.

680.32 Ground-Fault Circuit Interrupters Required. All electrical equipment, including power-supply cords, used with storable pools shall be protected by ground-fault circuit interrupters.

All 125-volt receptacles located within 6.0 m (20 ft) of the inside walls of a storable pool shall be protected by a ground-fault circuit interrupter. In determining these dimensions, the distance to be measured shall be the shortest path the supply cord of an appliance connected to the receptacle would follow without piercing a floor, wall, ceiling, doorway with hinged or sliding door, window opening, or other effective permanent barrier.

FPN: For flexible cord usage, see 400.4 in the *NEC*.

680.33 Luminaires (Lighting Fixtures). An underwater luminaire (lighting fixture), if installed, shall be installed in or on the wall of the storable pool. It shall comply with either 680.33(A) or 680.33(B).

(A) 15 Volts or Less. A luminaire (lighting fixture) shall be part of a cord-and-plug-connected lighting assembly. This assembly shall be listed as an assembly for the purpose and have the following construction features:

- (1) No exposed metal parts
- (2) A luminaire (fixture) lamp that operates at 15 volts or less
- (3) An impact-resistant polymeric lens, luminaire (fixture) body, and transformer enclosure
- (4) A transformer meeting the requirements of 680.23(A)(2) with a primary rating not over 150 volts

(B) Over 15 Volts But Not Over 150 Volts. A lighting assembly without a transformer and with the luminaire (fixture) lamp(s) operating at not over 150 volts shall be permitted to be cord-and-plug connected where the assembly is listed as an assembly for the purpose. The installation shall comply with 680.23(A)(5), and the assembly shall have the following construction features:

- (1) No exposed metal parts
- (2) An impact-resistant polymeric lens and luminaire (fixture) body
- (3) A ground-fault circuit interrupter with open neutral protection as an integral part of the assembly
- (4) The luminaire (fixture) lamp permanently connected to the ground-fault circuit interrupter with open-neutral protection
- (5) Compliance with the requirements of 680.23(A)

680.34 Receptacle Locations. Receptacles shall not be less than 3.0 m (10 ft) from the inside walls of a pool. In determining these dimensions, the distance to be measured

shall be the shortest path the supply cord of an appliance connected to the receptacle would follow without piercing a floor, wall, ceiling, doorway with hinged or sliding door, window opening, or other effective permanent barrier.

IV. Spas and Hot Tubs

680.40 General. Electrical installations at spas and hot tubs shall comply with the provisions of Part I and Part IV of this article.

680.41 Emergency Switch for Spas and Hot Tubs. A clearly labeled emergency shutoff or control switch for the purpose of stopping the motor(s) that provide power to the recirculation system and jet system shall be installed at a point readily accessible to the users and not less than 1.5 m (5 ft) away, adjacent to, and within sight of the spa or hot tub. This requirement shall not apply to single-family dwellings.

680.42 Outdoor Installations. A spa or hot tub installed outdoors shall comply with the provisions of Parts I and II of this article, except as permitted in 680.42(A) and 680.42(B), that would otherwise apply to pools installed outdoors.

(A) Flexible Connections. Listed packaged spa or hot tub equipment assemblies or self-contained spas or hot tubs utilizing a factory-installed or assembled control panel or panelboard shall be permitted to use flexible connections as covered in 680.42(A)(1) and (A)(2).

(1) Flexible Conduit. Liquidtight flexible metal conduit or liquidtight flexible nonmetallic conduit shall be permitted in lengths of not more than 1.8 m (6 ft).

(2) Cord-and-Plug Connections. Cord-and-plug connections with a cord not longer than 4.6 m (15 ft) shall be permitted where protected by a ground-fault circuit interrupter.

(B) Bonding. Bonding by metal-to-metal mounting on a common frame or base shall be permitted. The metal bands or hoops used to secure wooden staves shall not be required to be bonded as required in 680.26.

(C) Interior Wiring to Outdoor Installations. In the interior of a one-family dwelling or in the interior of another building or structure associated with a one-family dwelling, any of the wiring methods recognized in Chapter 3 of this Code that contain a copper equipment grounding conductor that is insulated or enclosed within the outer sheath of the wiring method and not smaller than 12 AWG shall be permitted to be used for the connection to motor, heating, and control loads that are part of a self-contained spa or hot tub or a packaged spa or hot tub equipment assembly. Wiring to an underwater light shall comply with 680.23 or 680.33.

680.43 Indoor Installations. A spa or hot tub installed indoors shall comply with the provisions of Parts I and II of this article except as modified by this section and shall be connected by the wiring methods of Chapter 3.

Exception: Listed spa and hot tub packaged units rated 20 amperes or less shall be permitted to be cord-and-plug connected to facilitate the removal or disconnection of the unit for maintenance and repair.

(A) Receptacles. At least one 125-volt, 15- or 20-ampere receptacle on a general-purpose branch circuit shall be located not less than 1.5 m (5 ft) from, and not exceeding 3.0 m (10 ft) from, the inside wall of the spa or hot tub.

(1) Location. Receptacles shall be located at least 1.5 m (5 ft) measured horizontally from the inside walls of the spa or hot tub.

(2) Protection, General. Receptacles rated 125 volts and 30 amperes or less and located within 3.0 m (10 ft) of the inside walls of a spa or hot tub shall be protected by a ground-fault circuit interrupter.

(3) Protection, Spa or Hot Tub Supply Receptacle. Receptacles that provide power for a spa or hot tub shall be ground-fault circuit-interrupter protected.

(4) Measurements. In determining the dimensions in this section addressing receptacle spacings, the distance to be measured shall be the shortest path the supply cord of an appliance connected to the receptacle would follow without piercing a floor, wall, ceiling, doorway with hinged or sliding door, window opening, or other effective permanent barrier.

(B) Installation of Luminaires (Lighting Fixtures), Lighting Outlets, and Ceiling-Suspended (Paddle) Fans.

(1) Elevation. Luminaires (lighting fixtures), except as covered in 680.43(B)(2), lighting outlets, and ceiling-suspended (paddle) fans located over the spa or hot tub or within 1.5 m (5 ft) from the inside walls of the spa or hot tub shall comply with the clearances specified in (B)(1)(a), (B)(1)(b), and (B)(1)(c) above the maximum water level.

(a) Without GFCI. Where no GFCI protection is provided, the mounting height shall be not less than 3.7 m (12 ft).

(b) With GFCI. Where GFCI protection is provided, the mounting height shall be permitted to be not less than 2.3 m (7 ft 6 in.).

(c) Below 2.3 m (7 ft 6 in.). Luminaires (lighting fixtures) meeting the requirements of item (1) or (2) and protected by a ground-fault circuit interrupter shall be permitted to be installed less than 2.3 m (7 ft 6 in.) over a spa or hot tub:

- (1) Recessed luminaires (fixtures) with a glass or plastic lens, nonmetallic or electrically isolated metal trim, and suitable for use in damp locations
- (2) Surface-mounted luminaires (fixtures) with a glass or plastic globe, a nonmetallic body, or a metallic body isolated from contact, and suitable for use in damp locations

(2) Underwater Applications. Underwater luminaires (lighting fixtures) shall comply with the provisions of 680.23 or 680.33.

(C) Wall Switches. Switches shall be located at least 1.5 m (5 ft), measured horizontally, from the inside walls of the spa or hot tub.

(D) Bonding. The following parts shall be bonded together:

- (1) All metal fittings within or attached to the spa or hot tub structure
- (2) Metal parts of electrical equipment associated with the spa or hot tub water circulating system, including pump motors
- (3) Metal conduit and metal piping that are within 1.5 m (5 ft) of the inside walls of the spa or hot tub and that are not separated from the spa or hot tub by a permanent barrier
- (4) All metal surfaces that are within 1.5 m (5 ft) of the inside walls of the spa or hot tub and that are not separated from the spa or hot tub area by a permanent barrier

Exception: Small conductive surfaces not likely to become energized, such as air and water jets and drain fittings, where not connected to metallic piping, towel bars, mirror frames, and similar nonelectrical equipment, shall not be required to be bonded.

- (5) Electrical devices and controls that are not associated with the spas or hot tubs and that are located not less than 1.5 m (5 ft) from such units; otherwise they shall be bonded to the spa or hot tub system

(E) Methods of Bonding. All metal parts associated with the spa or hot tub shall be bonded by any of the following methods:

- (1) The interconnection of threaded metal piping and fittings
- (2) Metal-to-metal mounting on a common frame or base
- (3) The provisions of a copper bonding jumper, insulated, covered, or bare, not smaller than 8 AWG solid.

(F) Grounding. The following equipment shall be grounded:

- (1) All electric equipment located within 1.5 m (5 ft) of the inside wall of the spa or hot tub

- (2) All electric equipment associated with the circulating system of the spa or hot tub

(G) Underwater Audio Equipment. Underwater audio equipment shall comply with the provisions of Part II of this article.

680.44 Protection. Except as otherwise provided in this section, the outlet(s) that supplies a self-contained spa or hot tub, a packaged spa or hot tub equipment assembly, or a field-assembled spa or hot tub shall be protected by a ground-fault circuit interrupter.

(A) Listed Units. If so marked, a listed self-contained unit or listed packaged equipment assembly that includes integral ground-fault circuit-interrupter protection for all electrical parts within the unit or assembly (pumps, air blowers, heaters, lights, controls, sanitizer generators, wiring, and so forth) shall be permitted without additional GFCI protection.

(B) Other Units. A field assembled spa or hot tub rated 3 phase or rated over 250 volts or with a heater load of more than 50 amperes shall not require the supply to be protected by a ground-fault circuit interrupter.

(C) Combination Pool and Spa or Hot Tub. A combination pool/hot tub or spa assembly commonly bonded need not be protected by a ground-fault circuit interrupter.

FPN: See 680.2 for definitions of self-contained spa or hot tub and for packaged spa or hot tub equipment assembly.

VII. Hydromassage Bathtubs

680.70 General. Hydromassage bathtubs as defined in 680.2 shall comply with Part VII of this article. They shall not be required to comply with other parts of this article.

680.71 Protection. Hydromassage bathtubs and their associated electrical components shall be protected by a ground-fault circuit interrupter. All 125-volt, single-phase receptacles not exceeding 30 amperes and located within 1.5 m (5 ft) measured horizontally of the inside walls of a hydromassage tub shall be protected by a ground-fault circuit interrupter(s).

680.72 Other Electrical Equipment. Luminaires (lighting fixtures), switches, receptacles, and other electrical equipment located in the same room, and not directly associated with a hydromassage bathtub, shall be installed in accordance with the requirements of Chapters 1 through 4 in this Code covering the installation of that equipment in bathrooms.

680.73 Accessibility. Hydromassage bathtub electrical equipment shall be accessible without damaging the building structure or building finish.

680.74 Bonding. All metal piping systems and all grounded metal parts in contact with the circulating water shall be bonded together using a copper bonding jumper, insulated, covered, or bare, not smaller than 8 AWG solid.

ARTICLE 690
Solar Photovoltaic Systems

Installations shall conform to the requirements of Article 690 of the 2005 *National Electrical Code* (NFPA 70-2005).

ARTICLE 692
Fuel Cell Systems

Installations shall conform to the requirements of Article 692 of the 2005 *National Electrical Code* (NFPA 70-2005).

Chapter 7 Special Conditions

ARTICLE 702 Optional Standby Systems

I. General

702.1 Scope. The provisions of this article apply to the installation and operation of optional standby systems.

The systems covered by this article consist of those that are permanently installed in their entirety, including prime movers, and those that are arranged for a connection to a premises wiring system from a portable alternate power supply.

702.2 Definition.

Optional Standby Systems. Those systems intended to supply power to public or private facilities or property where life safety does not depend on the performance of the system. Optional standby systems are intended to supply on-site generated power to selected loads either automatically or manually.

FPN: Optional standby systems are typically installed to provide an alternate source of electric power for such facilities as industrial and commercial buildings, farms, and residences and to serve loads such as heating and refrigeration systems, data processing and communications systems, and industrial processes that, when stopped during any power outage, could cause discomfort, serious interruption of the process, damage to the product or process, or the like.

702.3 Application of Other Articles. Except as modified by this article, all applicable articles of this *Code* shall apply.

702.4 Equipment Approval. All equipment shall be approved for the intended use.

702.5 Capacity and Rating. An optional standby system shall have adequate capacity and rating for the supply of all equipment intended to be operated at one time. Optional standby system equipment shall be suitable for the maximum available fault current at its terminals. The user of the optional standby system shall be permitted to select the load connected to the system.

702.6 Transfer Equipment. Transfer equipment shall be suitable for the intended use and designed and installed so as to prevent the inadvertent interconnection of normal and alternate sources of supply in any operation of the transfer equipment. Transfer equipment and electric power produc-

tion systems installed to permit operation in parallel with the normal source shall meet the requirements of Article 705 in the *NEC*.

Transfer equipment, located on the load side of branch circuit protection, shall be permitted to contain supplementary overcurrent protection having an interrupting rating sufficient for the available fault current that the generator can deliver. The supplementary overcurrent protection devices shall be part of a listed transfer equipment.

Transfer equipment shall be required for all standby systems subject to the provisions of this article and for which an electric-utility supply is either the normal or standby source.

702.7 Signals. Audible and visual signal devices shall be provided, where practicable, for the following purposes.

(1) Derangement. To indicate derangement of the optional standby source.

(2) Carrying Load. To indicate that the optional standby source is carrying load.

Exception: Signals shall not be required for portable standby power sources.

702.8 Signs.

(A) Standby. A sign shall be placed at the service-entrance equipment that indicates the type and location of on-site optional standby power sources. A sign shall not be required for individual unit equipment for standby illumination.

(B) Grounding. Where the grounded circuit conductor connected to the optional standby power source is connected to a grounding electrode conductor at a location remote from the optional standby power source, there shall be a sign at the grounding location that shall identify all optional standby power and normal sources connected at that location.

II. Circuit Wiring

702.9 Wiring Optional Standby Systems. The optional standby system wiring shall be permitted to occupy the same raceways, cables, boxes, and cabinets with other general wiring.

III. Grounding

702.10 Portable Generator Grounding.

(A) Separately Derived System. Where a portable optional standby source is used as a separately derived system,

it shall be grounded to a grounding electrode in accordance with 250.30 in the *NEC*.

(B) Nonseparately Derived System. Where a portable optional standby source is used as a nonseparately derived system, the equipment grounding conductor shall be bonded to the system grounding electrode.

IV. Sources of Power

702.11 Outdoor Generator Sets. Where an outdoor housed generator set is equipped with a readily accessible disconnecting means located within sight of the building or structure supplied, an additional disconnecting means shall not be required where ungrounded conductors serve or pass through the building or structure.

ARTICLE 725
Class 1, Class 2, and Class 3 Remote-Control,
Signaling, and Power-Limited Circuits

I. General

725.1 Scope. This article covers remote-control, signaling, and power-limited circuits that are not an integral part of a device or appliance.

FPN: The circuits described herein are characterized by usage and electrical power limitations that differentiate them from electric light and power circuits; therefore, alternative requirements to those of Chapters 1 through 4 are given with regard to minimum wire sizes, derating factors, overcurrent protection, insulation requirements, and wiring methods and materials.

725.2 Definitions.

Abandoned Class 2, Class 3, and PLTC Cable. Installed Class 2, Class 3, and PLTC cable that is not terminated at equipment and not identified for future use with a tag.

Class 1 Circuit. The portion of the wiring system between the load side of the overcurrent device or power-limited supply and the connected equipment. The voltage and power limitations of the source are in accordance with 725.21.

Class 2 Circuit. The portion of the wiring system between the load side of a Class 2 power source and the connected equipment. Due to its power limitations, a Class 2 circuit considers safety from a fire initiation standpoint and provides acceptable protection from electric shock.

Class 3 Circuit. The portion of the wiring system between the load side of a Class 3 power source and the connected equipment. Due to its power limitations, a Class 3 circuit

considers safety from a fire initiation standpoint. Since higher levels of voltage and current than for Class 2 are permitted, additional safeguards are specified to provide protection from an electric shock hazard that could be encountered.

725.3 Other Articles. Circuits and equipment shall comply with the articles or sections listed in 725.3(A) through 725.3(C). Only those sections of Article 300 referenced in this article shall apply to Class 1, Class 2, and Class 3 circuits.

(A) Number and Size of Conductors in Raceway. Section 300.17.

(B) Spread of Fire or Products of Combustion. Section 300.21. The accessible portion of abandoned Class 2, Class 3, and PLTC cables shall be removed.

(C) Ducts, Plenums, and Other Air-Handling Spaces. Class 1, Class 2, and Class 3 circuits installed in ducts, plenums, or other space used for environmental air shall comply with 300.22. Type CL2P or CL3P cables and plenum signaling raceways shall be permitted for Class 2 and Class 3 circuits installed in other spaces used for environmental air.

725.7 Access to Electrical Equipment Behind Panels Designed to Allow Access. Access to electrical equipment shall not be denied by an accumulation of wires and cables that prevents removal of panels, including suspended ceiling panels.

725.8 Mechanical Execution of Work. Class 1, Class 2, and Class 3 circuits shall be installed in a neat and workmanlike manner. Cables and conductors installed exposed on the surface of ceilings and sidewalls shall be supported by the building structure in such a manner that the cable will not be damaged by normal building use. Such cables shall be supported by straps, staples, hangers, or similar fittings designed and installed so as not to damage the cable. The installation shall also conform with 300.4(D).

725.10 Class 1, Class 2, and Class 3 Circuit Identification. Class 1, Class 2, and Class 3 circuits shall be identified at terminal and junction locations, in a manner that prevents unintentional interference with other circuits during testing and servicing.

725.11 Safety-Control Equipment.

(A) Remote-Control Circuits. Remote-control circuits for safety-control equipment shall be classified as Class 1 if the failure of the equipment to operate introduces a direct fire or life hazard. Room thermostats, water temperature regulating

devices, and similar controls used in conjunction with electrically controlled household heating and air conditioning shall not be considered safety-control equipment.

(B) Physical Protection. Where damage to remote-control circuits of safety control equipment would introduce a hazard, as covered in 725.11(A), all conductors of such remote-control circuits shall be installed in rigid metal conduit, intermediate metal conduit, rigid nonmetallic conduit, electrical metallic tubing, Type MI cable, Type MC cable, or be otherwise suitably protected from physical damage.

725.15 Class 1, Class 2, and Class 3 Circuit Requirements. A remote-control, signaling, or power-limited circuit shall comply with the following parts of this article:

- (1) Class 1 Circuits: Parts I and II
- (2) Class 2 and Class 3 Circuits: Parts I and III

II. Class 1 Circuits

725.21 Class 1 Circuit Classifications and Power Source Requirements. Class 1 circuits shall be classified as either Class 1 power-limited circuits where they comply with the power limitations of 725.21(A) or as Class 1 remote-control and signaling circuits where they are used for remote-control or signaling purposes and comply with the power limitations of 725.21(B).

(A) Class 1 Power-Limited Circuits. These circuits shall be supplied from a source that has a rated output of not more than 30 volts and 1000 volt-amperes.

(1) Class 1 Transformers. Transformers used to supply power-limited Class 1 circuits shall comply with the applicable sections within Parts I and II of Article 450 in the *NEC*.

(2) Other Class 1 Power Sources. Power sources other than transformers shall be protected by overcurrent devices rated at not more than 167 percent of the volt-ampere rating of the source divided by the rated voltage. The overcurrent devices shall not be interchangeable with overcurrent devices of higher ratings. The overcurrent device shall be permitted to be an integral part of the power supply.

(B) Class 1 Remote-Control and Signaling Circuits. These circuits shall not exceed 600 volts. The power output of the source shall not be required to be limited.

725.25 Class 1 Circuit Wiring Methods. Class 1 circuits shall be installed in accordance with Part I of Article 300 and with the wiring methods from the appropriate articles in Chapter 3.

Exception No. 1: The provisions of 725.26 through 725.28 in the NEC shall be permitted to apply in installations of Class 1 circuits.

III. Class 2 and Class 3 Circuits

725.41 Power Sources for Class 2 and Class 3 Circuits.

(A) Power Source. The power source for a Class 2 or a Class 3 circuit shall be as specified in 725.41(A)(1), (A)(2), (A)(3), (A)(4), or 725.41(A)(5) in the *NEC*:

FPN No. 2: Table 11(A) and Table 11(B) in Chapter 9 in the *NEC* provide the requirements for listed Class 2 and Class 3 power sources.

- (1) A listed Class 2 or Class 3 transformer
- (2) A listed Class 2 or Class 3 power supply
- (3) Other listed equipment marked to identify the Class 2 or Class 3 power source

Exception No. 2: Limited power circuits of listed equipment where these circuits have energy levels rated at or below the limits established in Chapter 9, Table 11(A) and Table 11(B) in the NEC.

- (4) Listed information technology (computer) equipment limited power circuits.

(B) Interconnection of Power Sources. Class 2 or Class 3 power sources shall not have the output connections paralleled or otherwise interconnected unless listed for such interconnection.

725.52 Wiring Methods and Materials on Load Side of the Class 2 or Class 3 Power Source. Class 2 and Class 3 circuits on the load side of the power source shall be permitted to be installed using wiring methods and materials in accordance with either 725.52(A) or 725.52(B).

(A) Class 1 Wiring Methods and Materials. Installation shall be in accordance with 725.25.

(B) Class 2 and Class 3 Wiring Methods. Conductors on the load side of the power source shall be insulated at not less than the requirements of 725.82 in the *NEC* and shall be installed in accordance with 725.55, 725.56, 725.58, and 725.61.

725.55 Separation from Electric Light, Power, Class 1, Non-Power-Limited Fire Alarm Circuit Conductors, and Medium Power Network-Powered Broadband Communications Cables.

(A) General. Cables and conductors of Class 2 and Class 3 circuits shall not be placed in any cable, cable tray, compartment, enclosure, manhole, outlet box, device box, raceway, or similar fitting with conductors of electric light, power, Class 1, non-power-limited fire alarm circuits, and medium power network-powered broadband communications circuits unless permitted by 725.55(D) and 725.55(J).

(D) Associated Systems Within Enclosures. Class 2 and Class 3 circuit conductors in compartments, enclosures, device boxes, outlet boxes, or similar fittings shall be permitted to be installed with electric light, power, Class 1, non-power-limited fire alarm, and medium power network-powered broadband communications circuits where they are introduced solely to connect the equipment connected to Class 2 and Class 3 circuits, and where (1) or (2) applies:

- (1) The electric light, power, Class 1, non-power-limited fire alarm, and medium power network-powered broadband communications circuit conductors are routed to maintain a minimum of 6 mm (0.25 in.) separation from the conductors and cables of Class 2 and Class 3 circuits.
- (2) The circuit conductors operate at 150 volts or less to ground and also comply with one of the following:
 - a. The Class 2 and Class 3 circuits are installed using Type CL3, CL3R, or CL3P or permitted substitute cables, provided these Class 3 cable conductors extending beyond the jacket are separated by a minimum of 6 mm (0.25 in.) or by a nonconductive sleeve or nonconductive barrier from all other conductors.
 - b. The Class 2 and Class 3 circuit conductors are installed as a Class 1 circuit in accordance with 725.21.

(J) Other Applications. For other applications, conductors of Class 2 and Class 3 circuits shall be separated by at least 50 mm (2 in.) from conductors of any electric light, power, Class 1 non-power-limited fire alarm or medium power network-powered broadband communications circuits unless one of the following conditions is met:

- (1) Either (a) all of the electric light, power, Class 1, non-power-limited fire alarm and medium power network-powered broadband communications circuit conductors or (b) all of the Class 2 and Class 3 circuit conductors are in a raceway or in metal-sheathed, metal-clad, non-metallic-sheathed, or Type UF cables.
- (2) All of the electric light, power, Class 1 non-power-limited fire alarm, and medium power network-powered broadband communications circuit conductors are permanently separated from all of the Class 2 and Class 3 circuit conductors by a continuous and firmly fixed nonconductor, such as porcelain tubes or flexible tubing, in addition to the insulation on the conductors.

725.56 Installation of Conductors of Different Circuits in the Same Cable, Enclosure, or Raceway.

(A) Two or More Class 2 Circuits. Conductors of two or more Class 2 circuits shall be permitted within the same cable, enclosure, or raceway.

(D) Class 2 and Class 3 Circuits with Communications Circuits.

(1) Classified as Communications Circuits. Class 2 and Class 3 circuit conductors shall be permitted in the same cable with communications circuits, in which case the Class 2 and Class 3 circuits shall be classified as communications circuits and shall be installed in accordance with the requirements of Article 800. The cables shall be listed as communications cables or multipurpose cables.

725.58 Support of Conductors. Class 2 or Class 3 circuit conductors shall not be strapped, taped, or attached by any means to the exterior of any conduit or other raceway as a means of support. These conductors shall be permitted to be installed as permitted by 300.11(B)(2).

725.61 Applications of Listed Class 2, Class 3, and PLTC Cables. Class 2, Class 3, and PLTC cables shall comply with any of the requirements described in 725.61(A), (B), (E), and (G).

(A) Plenums. Cables installed in ducts, plenums, and other spaces used for environmental air shall be Type CL2P or CL3P. Listed wires and cables installed in compliance with 300.22 shall be permitted. Listed plenum signaling raceways shall be permitted to be installed in other spaces used for environmental air as described in 300.22(C). Only Type CL2P or CL3P cable shall be permitted to be installed in these raceways.

(B) Riser. Cables installed in risers shall be as described in any of (B)(1), (B)(2), or (B)(3):

- (1) Cables installed in vertical runs and penetrating more than one floor, or cables installed in vertical runs in a shaft, shall be Type CL2R or CL3R. Floor penetrations requiring Type CL2R or CL3R shall contain only cables suitable for riser or plenum use. Listed riser signaling raceways shall be permitted to be installed in vertical riser runs in a shaft from floor to floor. Only Type CL2R, CL3R, CL2P, or CL3P cables shall be permitted to be installed in these raceways.
- (2) Other cables as covered in Table 725.61 and other listed wiring methods as covered in Chapter 3 shall be installed in metal raceways, or located in a fireproof shaft having firestops at each floor.
- (3) Type CL2, CL3, CL2X, and CL3X cables shall be permitted in one- and two-family dwellings. Listed general purpose signaling raceways shall be permitted for use with Type CL2, CL3, CL2X and CL3X cables.

FPN: See 300.21 for firestop requirements for floor penetrations.

(E) Other Wiring Within Buildings. Cables installed in building locations other than those covered in 725.61(A) and 725.61(B) shall be as described in any of (1) through (4).

- (1) Type CL2 or CL3 shall be permitted.
- (2) Type CL2X or CL3X shall be permitted to be installed in a raceway or in accordance with other wiring methods covered in Chapter 3.
- (3) Cables shall be permitted to be installed in nonconcealed spaces where the exposed length of cable does not exceed 3 m (10 ft).
- (4) Listed Type CL2X cables less than 6 mm (0.25 in.) in diameter and listed Type CL3X cables less than 6 mm (0.25 in.) in diameter shall be permitted to be installed in one- and two-family dwellings.

(G) Class 2 and Class 3 Cable Substitutions. The substitutions for Class 2 and Class 3 cables listed in Table 725.61 shall be permitted. Where substitute cables are installed, the wiring requirements of Article 725, Parts I and III, shall apply.

Table 725.61 Cable Substitutions

Cable Type	Permitted Substitutions
CL3P	CMP
CL2P	CMP, CL3P
CL3R	CMP, CL3P, CMR
CL2R	CMP, CL3P, CL2P, CMR, CL3R
PLTC	
CL3	CMP, CL3P, CMR, CL3R, CMG, CM, PLTC
CL2	CMP, CL3P, CL2P, CMR, CL3R, CL2R, CMG, CM, PLTC, CL3
CL3X	CMP, CL3P, CMR, CL3R, CMG, CM, PLTC, CL3, CMX
CL2X	CMP, CL3P, CL2P, CMR, CL3R, CL2R, CMG, CM, PLTC, CL3, CL2, CMX, CL3X

ARTICLE 760 Fire Alarm Systems

I. General

760.1 Scope. This article covers the installation of wiring and equipment of fire alarm systems including all circuits controlled and powered by the fire alarm system.

FPN No. 1: Fire alarm systems include fire detection and alarm notification, guard's tour, sprinkler waterflow, and sprinkler supervisory systems. Circuits controlled and powered by the fire alarm system include circuits for the control of building systems safety functions, elevator capture, elevator shutdown, door release, smoke doors and damper control, fire doors and damper control and fan shutdown, but only where these circuits are powered by and controlled by the fire alarm system. For further information on the installation and monitoring for integrity requirements for fire alarm

systems, refer to the *NFPA 72®-2002, National Fire Alarm Code®*.

FPN No. 2: Class 1, 2, and 3 circuits are defined in Article 725.

760.2 Definitions.

Abandoned Fire Alarm Cable. Installed fire alarm cable that is not terminated at equipment other than a connector and not identified for future use with a tag.

Fire Alarm Circuit. The portion of the wiring system between the load side of the overcurrent device or the power-limited supply and the connected equipment of all circuits powered and controlled by the fire alarm system. Fire alarm circuits are classified as either non-power-limited or power-limited.

Power-Limited Fire Alarm Circuit (PLFA). A fire alarm circuit powered by a source that complies with 760.41.

760.3 Other Articles. Circuits and equipment shall comply with 760.3(A), (B) and (D). Only those sections of Article 300 referenced in this article shall apply to fire alarm systems.

(A) Spread of Fire or Products of Combustion. Section 300.21. The accessible portion of abandoned fire alarm cables shall be removed.

(B) Ducts, Plenums, and Other Air-Handling Spaces. Section 300.22, where installed in ducts or plenums or other spaces used for environmental air.

Exception: As permitted in 760.30(B)(1) and (B)(2) in the NEC, and in 760.61(A).

(D) Corrosive, Damp, or Wet Locations. Sections 110.11, 300.6, and in 310.9 in the *NEC* where installed in corrosive, damp, or wet locations.

760.7 Access to Electrical Equipment Behind Panels Designed to Allow Access. Access to electrical equipment shall not be denied by an accumulation of conductors and cables that prevents removal of panels, including suspended ceiling panels.

760.8 Mechanical Execution of Work. Fire alarm circuits shall be installed in a neat workmanlike manner. Cables and conductors installed exposed on the surface of ceilings and sidewalls shall be supported by the building structure in such a manner that the cable will not be damaged by normal building use. Such cables shall be supported by straps, staples, hangers, or similar fittings designed and installed so as not to damage the cable. The installation shall also conform with 300.4(D).

FPN: One source of information describing industry practices is ANSI/NECA 305-2001, *Standard for Fire Alarm System Job Practice*.

760.9 Fire Alarm Circuit and Equipment Grounding.

Fire alarm circuits and equipment shall be grounded in accordance with Article 250.

760.10 Fire Alarm Circuit Identification. Fire alarm circuits shall be identified at terminal and junction locations in a manner that will prevent unintentional interference with the signaling circuit during testing and servicing.

760.11 Fire Alarm Circuits Extending Beyond One Building. Power-limited fire alarm circuits that extend beyond one building and run outdoors either shall meet the installation requirements of Parts II, III, and IV of Article 800 or shall meet the installation requirements of Part I of Article 300. Non-power-limited fire alarm circuits that extend beyond one building and run outdoors shall meet the installation requirements of Part I of Article 300 and the applicable sections of Part I of Article 225.

760.15 Fire Alarm Circuit Requirements. Fire alarm circuits shall comply with 760.15(A) and 760.15(B).

(A) Non-Power-Limited Fire Alarm (NPLFA) Circuits. See Parts I and II.

(B) Power-Limited Fire Alarm (PLFA) Circuits. See Parts I and III.

II. Non-Power-Limited Fire Alarm (NPLFA) Circuits

760.21 NPLFA Circuit Power Source Requirements.

The power source of non-power-limited fire alarm circuits shall comply with Chapters 1 through 4, and the output voltage shall not be more than 600 volts, nominal. These circuits shall not be supplied through ground-fault circuit interrupters or arc-fault circuit interrupters.

FPN: See 210.8(A)(5), Exception No. 3, for receptacles in dwelling-unit unfinished basements that supply power for fire alarm systems.

760.25 NPLFA Circuit Wiring Methods. Installation of non-power-limited fire alarm circuits shall be in accordance with 110.3(B), 300.11, 300.15, 300.17, and other appropriate articles of Chapter 3.

III. Power-Limited Fire Alarm (PLFA) Circuits

760.41 Power Sources for PLFA Circuits. The power source for a power-limited fire alarm circuit shall be as specified in 760.41(A), (B), or (C). These circuits shall not

be supplied through ground-fault circuit interrupters or arc-fault circuit interrupters.

FPN No. 1: Tables 12(A) and 12(B) in Chapter 9 in the *NEC* provide the listing requirements for power-limited fire alarm circuit sources.

FPN No. 2: See 210.8(A)(5), Exception No. 3, for receptacles in dwelling-unit unfinished basements that supply power for fire alarm systems.

(A) Transformers. A listed PLFA or Class 3 transformer.

(B) Power Supplies. A listed PLFA or Class 3 power supply.

(C) Listed Equipment. Listed equipment marked to identify the PLFA power source.

FPN: Examples of listed equipment are a fire alarm control panel with integral power source; a circuit card listed for use as a PLFA source, where used as part of a listed assembly; a current-limiting impedance, listed for the purpose or part of a listed product, used in conjunction with a non-power-limited transformer or a stored energy source, for example, storage battery, to limit the output current.

760.52 Wiring Methods and Materials on Load Side of the PLFA Power Source.

Fire alarm circuits on the load side of the power source shall be permitted to be installed using wiring methods and materials in accordance with 760.52(A), 760.52(B), or a combination of (A) and (B).

(A) NPLFA Wiring Methods and Materials. Installation shall be in accordance with 760.25, and conductors shall be solid or stranded copper.

(B) PLFA Wiring Methods and Materials. Power-limited fire alarm conductors and cables described in 760.82 in the *NEC* shall be installed as detailed in 760.52(B)(1) or (B)(2) of this section or 760.52(B)(3) in the *NEC*. Devices shall be installed in accordance with 110.3(B), 300.11(A), and 300.15.

(1) Exposed or Fished in Concealed Spaces. In raceway or exposed on the surface of ceiling and sidewalls or fished in concealed spaces. Cable splices or terminations shall be made in listed fittings, boxes, enclosures, fire alarm devices, or utilization equipment. Where installed exposed, cables shall be adequately supported and installed in such a way that maximum protection against physical damage is afforded by building construction such as baseboards, door frames, ledges, and so forth. Where located within 2.1 m (7 ft) of the floor, cables shall be securely fastened in an approved manner at intervals of not more than 450 mm (18 in.).

(2) Passing Through a Floor or Wall. In metal raceways or rigid nonmetallic conduit where passing through a floor or wall to a height of 2.1 m (7 ft) above the floor, unless

adequate protection can be afforded by building construction such as detailed in 760.52(B)(1) or unless an equivalent solid guard is provided.

760.55 Separation from Electric Light, Power, Class 1, NPLFA, and Medium Power Network-Powered Broadband Communications Circuit Conductors.

(A) General. Power-limited fire alarm circuit cables and conductors shall not be placed in any cable, cable tray, compartment, enclosure, manhole, outlet box, device box, raceway, or similar fitting with conductors of electric light, power, Class 1, non-power-limited fire alarm circuits, and medium power network-powered broadband communications circuits unless permitted by 760.55(D) and 760.55(G).

(D) Associated Systems Within Enclosures. Power-limited fire alarm conductors in compartments, enclosures, device boxes, outlet boxes, or similar fittings shall be permitted to be installed with electric light, power, Class 1, non-power-limited fire alarm, and medium power network-powered broadband communications circuits where they are introduced solely to connect the equipment connected to power-limited fire alarm circuits, and comply with either of the following conditions:

- (1) The electric light, power, Class 1, non-power-limited fire alarm, and medium power network-powered broadband communications circuit conductors are routed to maintain a minimum of 6 mm (0.25 in.) separation from the conductors and cables of power-limited fire alarm circuits.
- (2) The circuit conductors operate at 150 volts or less to ground and also comply with one of the following:
 - a. The fire alarm power-limited circuits are installed using Type FPL, FPLR, FPLP, or permitted substitute cables, provided these power-limited cable conductors extending beyond the jacket are separated by a minimum of 6 mm (0.25 in.) or by a nonconductive sleeve or nonconductive barrier from all other conductors.
 - b. The power-limited fire alarm circuit conductors are installed as non-power-limited circuits in accordance with 760.25.

(G) Other Applications. For other applications, power-limited fire alarm circuit conductors shall be separated by at least 50 mm (2 in.) from conductors of any electric light, power, Class 1, non-power-limited fire alarm, or medium power network-powered broadband communications circuits unless one of the following conditions is met:

- (1) Either (a) all of the electric light, power, Class 1, non-power-limited fire alarm, and medium power network-powered broadband communications circuit con-

ductors or (b) all of the power-limited fire alarm circuit conductors are in a raceway or in metal-sheathed, metal-clad, nonmetallic-sheathed, or Type UF cables.

- (2) All of the electric light, power, Class 1, non-power-limited fire alarm, and medium power network-powered broadband communications circuit conductors are permanently separated from all of the power-limited fire alarm circuit conductors by a continuous and firmly fixed nonconductor, such as porcelain tubes or flexible tubing, in addition to the insulation on the conductors.

760.56 Installation of Conductors of Different PLFA Circuits, Class 2, Class 3, and Communications Circuits in the Same Cable, Enclosure, or Raceway.

(A) Two or More PLFA Circuits. Cable and conductors of two or more power-limited fire alarm circuits, communications circuits, or Class 3 circuits shall be permitted within the same cable, enclosure, or raceway.

760.57 Conductor Size. Conductors of 26 AWG shall be permitted only where spliced with a connector listed as suitable for 26 AWG to 24 AWG or larger conductors that are terminated on equipment or where the 26 AWG conductors are terminated on equipment listed as suitable for 26 AWG conductors. Single conductors shall not be smaller than 18 AWG.

760.58 Support of Conductors. Power-limited fire alarm circuit conductors shall not be strapped, taped, or attached by any means to the exterior of any conduit or other raceway as a means of support.

760.61 Applications of Listed PLFA Cables. PLFA cables shall comply with the requirements described in either 760.61(A), (B), or (C) or where cable substitutions are made as shown in 760.61(D).

(A) Plenum. Cables installed in ducts, plenums, and other spaces used for environmental air shall be Type FPLP. Types FPLP, FPLR, and FPL cables installed in compliance with 300.22 shall be permitted. Type FPLP-CI cable shall be permitted to be installed to provide a 2-hour circuit integrity rated cable.

(B) Riser. Cables installed in risers shall be as described in either (1), (2), or (3):

- (1) Cables installed in vertical runs and penetrating more than one floor, or cables installed in vertical runs in a shaft, shall be Type FPLR. Floor penetrations requiring Type FPLR shall contain only cables suitable for riser or plenum use. Type FPLR-CI cable shall be permitted to be installed to provide a 2-hour circuit integrity rated cable.

- (2) Other cables shall be installed in metal raceways or located in a fireproof shaft having firestops at each floor.
- (3) Type FPL cable shall be permitted in one- and two-family dwellings.

FPN: See 300.21 for firestop requirements for floor penetrations.

(C) Other Wiring Within Buildings. Cables installed in building locations other than those covered in 760.61(A) or 760.61(B) shall be as described in either (1), (2), (3), or (4). Type FPL-CI cable shall be permitted to be installed as described in either (1), (2), or (3) to provide a 2-hour circuit integrity rated cable.

- (1) Type FPL shall be permitted.
- (2) Cables shall be permitted to be installed in raceways.
- (3) Cables specified in Chapter 3 and meeting the requirements of 760.82(A) and 760.82(B) in the *NEC* shall be permitted to be installed in nonconcealed spaces where

the exposed length of cable does not exceed 3 m (10 ft).

(D) Fire Alarm Cable Substitutions. The substitutions for fire alarm cables listed in Table 760.61 shall be permitted. Where substitute cables are installed, the wiring requirements of Article 760, Parts I and III shall apply.

FPN: For information on communications cables (CMP, CMR, CMG, CM), see 800.179 in the *NEC*.

Table 760.61 Cable Substitutions

Cable Type	References	Permitted Substitutions
FPLP	760.61(A)	CMP
FPLR	760.61(B)	CMP, FPLP, CMR
FPL	760.61(C)	CMP, FPLP, CMR, FPLR, CMG, CM

Chapter 8 Communications Systems

ARTICLE 800 Communications Circuits

I. General

800.1 Scope. This article covers telephone, telegraph (except radio), outside wiring for fire alarm and burglar alarm, and similar central station systems; and telephone systems not connected to a central station system but using similar types of equipment, methods of installation, and maintenance.

FPN No. 1: For further information for fire alarm, sprinkler waterflow, and sprinkler supervisory systems, see Article 760.

FPN No. 3: For installation requirements for network-powered broadband communications circuits, see Article 830.

800.2 Definitions. See Article 100. For purposes of this article, the following additional definitions apply.

Abandoned Communications Cable. Installed communications cable that is not terminated at both ends at a connector or other equipment and not identified for future use with a tag.

Cable. A factory assembly of two or more conductors having an overall covering.

Cable Sheath. A covering over the conductor assembly that may include one or more metallic members, strength members, or jackets.

Communications Equipment. The electronic equipment that performs the telecommunications operations for the transmission of audio, video, and data, and including power equipment (e.g., dc converters, inverters and batteries) and technical support equipment (e.g., computers).

Exposed. A circuit that is in such a position that, in case of failure of supports and insulation, contact with another circuit may result.

FPN: See Article 100 for two other definitions of *Exposed*.

Point of Entrance. Within a building, the point at which the wire or cable emerges from an external wall, from a concrete floor slab, or from a rigid metal conduit or an intermediate metal conduit grounded to an electrode in accordance with 800.100(B).

Premises. The land and buildings of a user located on the user side of the utility-user network point of demarcation.

800.3 Other Articles.

(C) Spread of Fire or Products of Combustion. Section 300.21 shall apply. The accessible portion of abandoned communications cables shall not be permitted to remain.

(D) Equipment in Other Space Used for Environmental Air. Section 300.22(C) shall apply.

800.18 Installation of Equipment. Equipment electrically connected to a telecommunications network shall be listed in accordance with 800.170 in the *NEC*. Installation of equipment shall also comply with 110.3(B).

800.21 Access to Electrical Equipment Behind Panels Designed to Allow Access. Access to electrical equipment shall not be denied by an accumulation of wires and cables that prevents removal of panels, including suspended ceiling panels.

800.24 Mechanical Execution of Work. Communications circuits and equipment shall be installed in a neat and workmanlike manner. Cables installed exposed on the surface of ceilings and sidewalls shall be supported by the building structure in such a manner that the cable will not be damaged by normal building use. Such cables shall be secured by straps, staples, hangers, or similar fittings designed and installed so as not to damage the cable. The installation shall also conform with 300.4(D) and 300.11.

II. Wires and Cables Outside and Entering Buildings

800.44 Overhead Communications Wires and Cables. Overhead communications wires and cables entering buildings shall comply with 800.44(B).

(B) Above Roofs. Communications wires and cables shall have a vertical clearance of not less than 2.5 m (8 ft) from all points of roofs above which they pass.

Exception No. 1: Auxiliary buildings, such as garages and the like.

Exception No. 2: A reduction in clearance above only the overhanging portion of the roof to not less than 450 mm (18 in.) shall be permitted if (a) not more than 1.2 m (4 ft) of communications service-drop conductors pass above the roof overhang and (b) they are terminated at a through- or above-the-roof raceway or approved support.

Exception No. 3: Where the roof has a slope of not less than 100 mm in 300 mm (4 in. in 12 in.), a reduction in clearance to not less than 900 mm (3 ft) shall be permitted.

III. Protection

800.90 Protective Devices.

(A) Application. A listed primary protector shall be provided on each circuit run partly or entirely in aerial wire or aerial cable not confined within a block. Also, a listed primary protector shall be provided on each circuit, aerial or underground, located within the block containing the building served so as to be exposed to accidental contact with electric light or power conductors operating at over 300 volts to ground. In addition, where there exists a lightning exposure, each interbuilding circuit on a premises shall be protected by a listed primary protector at each end of the interbuilding circuit. Installation of primary protectors shall also comply with 110.3(B).

FPN No. 1: On a circuit not exposed to accidental contact with power conductors, providing a listed primary protector in accordance with this article helps protect against other hazards, such as lightning and above-normal voltages induced by fault currents on power circuits in proximity to the communications circuit.

(B) Location. The primary protector shall be located in, on, or immediately adjacent to the structure or building served and as close as practicable to the point of entrance.

FPN: See 800.2 for the definition of *point of entrance*.

For purposes of this section, primary protectors located at mobile home service equipment located in sight from and not more than 9.0 m (30 ft) from the exterior wall of the mobile home it serves, or at a mobile home disconnecting means grounded in accordance with 250.32 and located in sight from and not more than 9.0 m (30 ft) from the exterior wall of the mobile home it serves, shall be considered to meet the requirements of this section.

FPN: Selecting a primary protector location to achieve the shortest practicable primary protector grounding conductor helps limit potential differences between communications circuits and other metallic systems.

800.93 Cable Grounding. The metallic sheath of communications cables entering buildings shall be grounded as close as practicable to the point of entrance or shall be interrupted as close to the point of entrance as practicable by an insulating joint or equivalent device.

FPN: See 800.2 for the definition of *point of entrance*.

IV. Grounding Methods

800.100 Cable and Primary Protector Grounding. The metallic member(s) of the cable sheath, where required to be grounded by 800.93, and primary protectors shall be grounded as specified in 800.100(A) through 800.100(D).

(A) Grounding Conductor.

(1) Insulation. The grounding conductor shall be insulated and shall be listed as suitable for the purpose.

(2) Material. The grounding conductor shall be copper or other corrosion-resistant conductive material, stranded or solid.

(3) Size. The grounding conductor shall not be smaller than 14 AWG.

(4) Length. The primary protector grounding conductor shall be as short as practicable. In one- and two-family dwellings, the primary protector grounding conductor shall be as short as practicable, not to exceed 6.0 m (20 ft) in length.

Exception: In one- and two-family dwellings where it is not practicable to achieve an overall maximum primary protector grounding conductor length of 6.0 m (20 ft), a separate communications ground rod meeting the minimum dimensional criteria of 800.100(B)(2)(2) shall be driven, the primary protector shall be grounded to the communications ground rod in accordance with 800.100(C), and the communications ground rod shall be bonded to the power grounding electrode system in accordance with 800.100(D).

(5) Run in Straight Line. The grounding conductor shall be run to the grounding electrode in as straight a line as practicable.

(6) Physical Damage. Where necessary, the grounding conductor shall be guarded from physical damage. Where the grounding conductor is run in a metal raceway, both ends of the raceway shall be bonded to the grounding conductor or the same terminal or electrode to which the grounding conductor is connected.

(B) Electrode. The grounding conductor shall be connected in accordance with 800.100(B)(1) and (B)(2).

(1) In Buildings or Structures with Grounding Means. To the nearest accessible location on the following:

- (1) The building or structure grounding electrode system as covered in 250.50
- (2) The grounded interior metal water piping system, within 1.5 m (5 ft) from its point of entrance to the building, as covered in 250.52
- (3) The power service accessible means external to enclosures as covered in 250.94
- (4) The metallic power service raceway
- (5) The service equipment enclosure
- (6) The grounding electrode conductor or the grounding electrode conductor metal enclosure
- (7) The grounding conductor or the grounding electrode

of a building or structure disconnecting means that is grounded to an electrode as covered in 250.32

For purposes of this section, the mobile home service equipment or the mobile home disconnecting means, as described in 800.90(B), shall be considered accessible.

(2) In Buildings or Structures Without Grounding Means. If the building or structure served has no grounding means, as described in 800.100(B)(1), the grounding conductor shall be connected to either of the following:

- (1) To any one of the individual electrodes described in 250.52(A)(1), (A)(2), (A)(3), or (A)(4)
- (2) If the building or structure served has no grounding means, as described in 800.100(B)(1) or (B)(2)(1), to an effectively grounded metal structure or to a ground rod or pipe not less than 1.5 m (5 ft) in length and 12.7 mm (½ in.) in diameter, driven, where practicable, into permanently damp earth and separated from lightning conductors as covered in 800.53 and at least 1.8 m (6 ft) from electrodes of other systems. Steam or hot water pipes or air terminal conductors (lightning-rod conductors) shall not be employed as electrodes for protectors.

(C) Electrode Connection. Connections to grounding electrodes shall comply with 250.70.

(D) Bonding of Electrodes. A bonding jumper not smaller than 6 AWG copper or equivalent shall be connected between the communications grounding electrode and power grounding electrode system at the building or structure served where separate electrodes are used.

Exception: At mobile homes as covered in 800.106.

FPN No. 1: See 250.60 for use of air terminals (lightning rods).

FPN No. 2: Bonding together of all separate electrodes limits potential differences between them and between their associated wiring systems.

800.106 Primary Protector Grounding and Bonding at Mobile Homes.

(A) Grounding. Where there is no mobile home service equipment located in sight from, and not more than 9.0 m (30 ft) from, the exterior wall of the mobile home it serves, or there is no mobile home disconnecting means grounded in accordance with 250.32 and located within sight from, and not more than 9.0 m (30 ft) from, the exterior wall of the mobile home it serves, the primary protector ground shall be in accordance with 800.100(B)(2).

(B) Bonding. The primary protector grounding terminal or grounding electrode shall be bonded to the metal frame or

available grounding terminal of the mobile home with a copper grounding conductor not smaller than 12 AWG under either of the following conditions:

- (1) Where there is no mobile home service equipment or disconnecting means as in 800.106(A)
- (2) Where the mobile home is supplied by cord and plug

V. Communications Wires and Cables Within Buildings

800.110 Raceways for Communications Wires and Cables. Where communications wires and cables are installed in a raceway, the raceway shall be either of a type permitted in Chapter 3 and installed in accordance with Chapter 3 or a listed nonmetallic raceway complying with 800.182 in the *NEC*, and installed in accordance with 362.24 through 362.56, where the requirements applicable to electrical non-metallic tubing apply.

Exception: Conduit fill restrictions shall not apply.

800.113 Installation and Marking of Communications Wires and Cables. Listed communications wires and cables and listed multipurpose cables shall be installed as wiring within buildings.

800.133 Installation of Communications Wires, Cables, and Equipment. Communications wires and cables from the protector to the equipment or, where no protector is required, communications wires and cables attached to the outside or inside of the building shall comply with 800.133(A) and 800.133(C).

(A) Separation from Other Conductors.

(1) In Raceways, Boxes, and Cables.

(a) Other Power-Limited Circuits. Communications cables shall be permitted in the same raceway or enclosure with cables of any of the following:

- (1) Class 2 and Class 3 remote-control, signaling, and power-limited circuits in compliance with Article 725
- (2) Power-limited fire alarm systems in compliance with Article 760
- (3) Nonconductive and conductive optical fiber cables in compliance with Article 770 in the *NEC*
- (4) Community antenna television and radio distribution systems in compliance with Article 820
- (5) Low-power network-powered broadband communications circuits in compliance with Article 830

(c) Electric Light, Power, Class 1, Non-Power-Limited Fire Alarm, and Medium Power Network-Powered Broadband Communications Circuits in Raceways, Compartments, and Boxes. Communications conductors shall not be

placed in any raceway, compartment, outlet box, junction box, or similar fitting with conductors of electric light, power, Class 1, non-power-limited fire alarm, or medium power network-powered broadband communications circuits.

Exception No. 1: Where all of the conductors of electric light, power, Class 1, non-power-limited fire alarm, and medium power network-powered broadband communications circuits are separated from all of the conductors of communications circuits by a permanent barrier or listed divider.

Exception No. 2: Power conductors in outlet boxes, junction boxes, or similar fittings or compartments where such conductors are introduced solely for power supply to communications equipment. The power circuit conductors shall be routed within the enclosure to maintain a minimum of 6 mm (0.25 in.) separation from the communications circuit conductors.

(2) Other Applications. Communications wires and cables shall be separated at least 50 mm (2 in.) from conductors of any electric light, power, Class 1, non-power-limited fire alarm, or medium power network-powered broadband communications circuits.

Exception No. 1: Where either (1) all of the conductors of the electric light, power, Class 1, non-power-limited fire alarm, and medium power network-powered broadband communications circuits are in a raceway or in metal-sheathed, metal-clad, nonmetallic-sheathed, Type AC, or Type UF cables, or (2) all of the conductors of communications circuits are encased in raceway.

(C) Support of Conductors. Raceways shall be used for their intended purpose. Communications cables or wires shall not be strapped, taped, or attached by any means to the exterior of any conduit or raceway as a means of support.

Exception: Overhead (aerial) spans of communications cables or wires shall be permitted to be attached to the exterior of a raceway-type mast intended for the attachment and support of such conductors.

800.154 Applications of Listed Communications Wires and Cables and Communications Raceways. Communications wires and cables shall comply with the requirements of 800.154(A), (B), and (E) or where cable substitutions are made in accordance with 800.154(G).

(A) Plenum. Cables installed in ducts, plenums, and other spaces used for environmental air shall be Type CMP. Abandoned cables shall not be permitted to remain. Types CMP, CMR, CMG, CM, and CMX and communications wire installed in compliance with 300.22 shall be permitted. Listed plenum communications raceways shall be permitted to be

installed in ducts and plenums as described in 300.22(B) and in other spaces used for environmental air as described in 300.22(C). Only Type CMP cable shall be permitted to be installed in raceways.

(B) Riser. Cables installed in risers shall comply with 800.154(B)(1), (B)(2), or (B)(3).

(1) Cables in Vertical Runs. Cables installed in vertical runs and penetrating more than one floor, or cables installed in vertical runs in a shaft, shall be Type CMR. Floor penetrations requiring Type CMR shall contain only cables suitable for riser or plenum use. Abandoned cables shall not be permitted to remain. Listed riser communications raceways shall be permitted to be installed in vertical riser runs in a shaft from floor to floor. Only Type CMR and CMP cables shall be permitted to be installed in these raceways.

(2) Metal Raceways or Fireproof Shafts. Listed communications cables shall be encased in a metal raceway or located in a fireproof shaft having firestops at each floor.

(3) One- and Two-Family Dwellings. Type CM and CMX cable shall be permitted in one- and two-family dwellings.

FPN: See 800.3(C) for firestop requirements for floor penetrations.

(E) Other Wiring Within Buildings. Cables installed in building locations other than the locations covered in 800.154(A) and 800.154(B) shall be in accordance with 800.154(E)(1) through (E)(4).

(1) General. Cables shall be Type CMG or Type CM. Listed communications general-purpose raceways shall be permitted. Only Types CMG, CM, CMR, or CMP cables shall be permitted to be installed in general-purpose communications raceways.

(2) In Raceways. Listed communications wires that are enclosed in a raceway of a type included in Chapter 3 shall be permitted.

(3) Nonconcealed Spaces. Type CMX communications cable shall be permitted to be installed in nonconcealed spaces where the exposed length of cable does not exceed 3 m (10 ft).

(4) One- and Two-Family Dwellings. Type CMX communications cable less than 6 mm (0.25 in.) in diameter shall be permitted to be installed in one- and two-family dwellings.

(G) Cable Substitutions. The uses and permitted substitutions for communications cables listed in Table 800.154 shall be considered suitable for the purpose and shall be permitted.

FPN: For information on Types CMP, CMR, CMG, CM, and CMX cables, see 800.179 in the *NEC*.

Table 800.154 Cable Substitutions

Cable Type	Use	References	Permitted Substitutions
CMR	Communications riser cable	800.154(B)	CMP
CMG, CM	Communications general-purpose cable	800.154(E)(1)	CMP, CMR
CMX	Communications cable, limited use	800.154(E)	CMP, CMR, CMG, CM

FPN: See Figure 800.154, Cable Substitution Hierarchy.

ARTICLE 820 Community Antenna Television and Radio Distribution Systems

I. General

820.1 Scope. This article covers coaxial cable distribution of radio frequency signals typically employed in community antenna television (CATV) systems.

820.2 Definitions. See Article 100. For the purposes of this article, the following additional definitions apply.

Abandoned Coaxial Cable. Installed coaxial cable that is not terminated at equipment other than a coaxial connector and not identified for future use with a tag.

Exposed. An exposed cable is one that is in such a position that, in case of failure of supports and insulation, contact with another circuit could result.

FPN: See Article 100 for two other definitions of *exposed*.

Point of Entrance. The point within a building at which the cable emerges from an external wall, from a concrete floor slab, or from a rigid metal conduit or an intermediate metal conduit grounded to an electrode in accordance with 820.100(B).

Premises. The land and buildings of a user located on the user side of utility-user network point of demarcation.

820.3 Other Articles. Circuits and equipment shall comply with 820.3(A) through 820.3(G).

(A) Spread of Fire or Products of Combustion. Section 300.21 shall apply. The accessible portion of abandoned coaxial cables shall be removed.

(B) Ducts, Plenums, and Other Air-Handling Spaces. Section 300.22, where installed in ducts, plenums, or other spaces used for environmental air, shall apply.

Exception: As permitted in 820.154(A).

(C) Installation and Use. Section 110.3 shall apply.

(D) Installations of Conductive and Nonconductive Optical Fiber Cables. Article 770 in the *NEC* shall apply.

(E) Communications Circuits. Article 800 shall apply.

(F) Network-Powered Broadband Communications Systems. Article 830 shall apply.

(G) Alternate Wiring Methods. The wiring methods of Article 830 shall be permitted to substitute for the wiring methods of Article 820.

FPN: Use of Article 830 wiring methods will facilitate the upgrading of Article 820 installations to network-powered broadband applications.

820.15 Energy Limitations. Coaxial cable shall be permitted to deliver low-energy power to equipment that is directly associated with the radio frequency distribution system if the voltage is not over 60 volts and if the current supply is from a transformer or other device that has energy-limiting characteristics.

820.21 Access to Electrical Equipment Behind Panels Designed to Allow Access. Access to electrical equipment shall not be denied by an accumulation of wires and cables that prevents removal of panels, including suspended ceiling panels.

820.24 Mechanical Execution of Work. Community antenna television and radio distribution systems shall be installed in a neat and workmanlike manner. Cables installed exposed on the surface of ceiling and sidewalls shall be supported by the building structure in such a manner that the cable will not be damaged by normal building use. Such cables shall be secured by straps, staples, hangers, or similar fittings designed and installed so as not to damage the cable. The installation shall also conform with 300.4(D) and 300.11.

II. Cables Outside and Entering Buildings

820.44 Overhead Cables. Coaxial cables, prior to the point of grounding, as defined in 820.93, shall comply with 820.44(C) and 820.44(D).

(C) On Masts. Aerial cable shall be permitted to be attached to an above-the-roof raceway mast that does not enclose or support conductors of electric light or power circuits.

(D) Above Roofs. Cables shall have a vertical clearance of not less than 2.5 m (8 ft) from all points of roofs above which they pass.

Exception No. 1: Auxiliary buildings such as garages and the like.

Exception No. 2: A reduction in clearance above only the overhanging portion of the roof to not less than 450 mm (18 in.) shall be permitted if (1) not more than 1.2 m (4 ft) of communications service drop conductors pass above the roof overhang, and (2) they are terminated at a raceway mast or other approved support.

Exception No. 3: Where the roof has a slope of not less than 100 mm in 300 mm (4 in. in 12 in.), a reduction in clearance to not less than 900 mm (3 ft) shall be permitted.

820.47 Underground Circuits Entering Buildings.

(B) Direct-Buried Cables and Raceways. Direct-buried coaxial cable shall be separated at least 300 mm (12 in.) from conductors of any light or power or Class 1 circuit.

Exception No. 1: Where electric service conductors or coaxial cables are installed in raceways or have metal cable armor.

Exception No. 2: Where electric light or power branch-circuit or feeder conductors or Class 1 circuit conductors are installed in a raceway or in metal-sheathed, metal-clad, or Type UF or Type USE cables; or the coaxial cables have metal cable armor or are installed in a raceway.

III. Protection

820.93 Grounding of Outer Conductive Shield of a Coaxial Cable. The outer conductive shield of the coaxial cable shall be grounded at the building premises as close to the point of cable entrance or attachment as practicable.

For purposes of this section, grounding located at mobile home service equipment located in sight from, and not more than 9.0 m (30 ft) from, the exterior wall of the mobile home it serves, or at a mobile home disconnecting means grounded in accordance with 250.32 and located in sight from and not more than 9.0 m (30 ft) from the exterior wall of the mobile home it serves, shall be considered to meet the requirements of this section.

FPN: Selecting a grounding location to achieve the shortest practicable grounding conductor helps limit potential differences between CATV and other metallic systems.

(A) Shield Grounding. Where the outer conductive shield of a coaxial cable is grounded, no other protective devices shall be required.

(B) Shield Protection Devices. Grounding of a coaxial drop cable shield by means of a protective device that does not interrupt the grounding system within the premises shall be permitted.

IV. Grounding Methods

820.100 Cable Grounding. Where required by 820.93, the shield of the coaxial cable shall be grounded as specified in 820.100(A) through 820.100(D).

(A) Grounding Conductor.

(1) Insulation. The grounding conductor shall be insulated and shall be listed as suitable for the purpose.

(2) Material. The grounding conductor shall be copper or other corrosion-resistant conductive material, stranded or solid.

(3) Size. The grounding conductor shall not be smaller than 14 AWG. It shall have a current-carrying capacity approximately equal to that of the outer conductor of the coaxial cable. The grounding conductor shall not be required to exceed 6 AWG.

(4) Length. The grounding conductor shall be as short as practicable. In one- and two-family dwellings, the grounding conductor shall be as short as practicable, not to exceed 6.0 m (20 ft) in length.

Exception: In one- and two-family dwellings where it is not practicable to achieve an overall maximum grounding conductor length of 6.0 m (20 ft), a separate ground as specified in 250.52(A)(5), (A)(6), or (A)(7) shall be used, the grounding conductor shall be grounded to the separate ground in accordance with 250.70, and the separate ground bonded to the power grounding electrode system in accordance with 820.100(D).

(5) Run in Straight Line. The grounding conductor shall be run to the grounding electrode in as straight a line as practicable.

(6) Physical Protection. Where subject to physical damage, the grounding conductor shall be adequately protected. Where the grounding conductor is run in a metal raceway, both ends of the raceway shall be bonded to the grounding conductor or the same terminal or electrode to which the grounding conductor is connected.

(B) Electrode. The grounding conductor shall be connected in accordance with 820.100(B)(1) and (B)(2).

(1) In Buildings or Structures with Grounding Means. To the nearest accessible location on the following:

- (1) The building or structure grounding electrode system as covered in 250.50
- (2) The grounded interior metal water piping system, within 1.52 m (5 ft) from its point of entrance to the building, as covered in 250.52

- (3) The power service accessible means external to enclosures as covered in 250.94
- (4) The metallic power service raceway
- (5) The service equipment enclosure
- (6) The grounding electrode conductor or the grounding electrode conductor metal enclosure, or
- (7) The grounding conductor or the grounding electrode of a building or structure disconnecting means that is grounded to an electrode as covered in 250.32

(2) In Buildings or Structures Without Grounding Means. If the building or structure served has no grounding means, as described in 820.100(B)(1):

- (1) To any one of the individual electrodes described in 250.52(A)(1), (A)(2), (A)(3), (A)(4); or,
- (2) If the building or structure served has no grounding means, as described in 820.100(B)(1) or (B)(2)(1), to an effectively grounded metal structure or to any one of the individual electrodes described in 250.52(A)(5), (A)(6), and (A)(7).

(C) Electrode Connection. Connections to grounding electrodes shall comply with 250.70.

(D) Bonding of Electrodes. A bonding jumper not smaller than 6 AWG copper or equivalent shall be connected between the community antenna television system's grounding electrode and the power grounding electrode system at the building or structure served where separate electrodes are used.

Exception: At mobile homes as covered in 820.106.

FPN No. 1: See 250.60 for use of air terminals (lightning rods).

FPN No. 2: Bonding together of all separate electrodes limits their potential differences between them and between their associated wiring systems.

820.103 Equipment Grounding. Unpowered equipment and enclosures or equipment powered by the coaxial cable shall be considered grounded where connected to the metallic cable shield.

820.106 Bonding and Grounding at Mobile Homes.

(A) Grounding. Where there is no mobile home service equipment located in sight from, and not more than 9.0 m (30 ft) from, the exterior wall of the mobile home it serves or there is no mobile home disconnecting means grounded in accordance with 250.32 and located within sight from, and not more than 9.0 m (30 ft) from, the exterior wall of the mobile home it serves, the coaxial cable shield ground, or surge arrester ground, shall be in accordance with 820.100(B)(2).

(B) Bonding. The coaxial cable shield grounding terminal, surge arrester grounding terminal, or grounding electrode shall be bonded to the metal frame or available grounding terminal of the mobile home with a copper grounding conductor not smaller than 12 AWG under any of the following conditions:

- (1) Where there is no mobile home service equipment or disconnecting means as in 820.106(A)
- (2) Where the mobile home is supplied by cord and plug

V. Cables Within Buildings

820.110 Raceways for Coaxial Cables. Where coaxial cables are installed in a raceway, the raceway shall be either of a type permitted in Chapter 3 and installed in accordance with Chapter 3 or a listed nonmetallic raceway complying with 820.182(A), (B), or (C) in the *NEC*, as applicable, and installed in accordance with 362.24 through 362.56, where the requirements applicable to electrical nonmetallic tubing apply.

Exception: Conduit fill restrictions shall not apply.

820.113 Installation and Marking of Coaxial Cables. Listed coaxial cables shall be installed as wiring within buildings. Coaxial cables shall be marked in accordance with Table 820.113 in the *NEC*. The cable voltage rating shall not be marked on the cable.

820.133 Installation of Cables and Equipment. Beyond the point of grounding, as defined in 820.93, the cable installation shall comply with 820.133(A) and 820.133(C).

(A) Separation from Other Conductors.

(1) In Raceways and Boxes.

- (1) Other Circuits. Coaxial cables shall be permitted in the same raceway or enclosure with jacketed cables of any of the following:
 - a. Class 2 and Class 3 remote-control, signaling, and power-limited circuits in compliance with Article 725
 - b. Power-limited fire alarm systems in compliance with Article 760
 - c. Nonconductive and conductive optical fiber cables in compliance with Article 770 in the *NEC*
 - d. Communications circuits in compliance with Article 800
 - e. Low-power network-powered broadband communications circuits in compliance with Article 830
- (2) Electric Light, Power, Class 1, Non-Power-Limited Fire Alarm, and Medium Power Network-Powered Broadband Communications Circuits. Coaxial cable shall not

be placed in any raceway, compartment, outlet box, junction box, or other enclosures with conductors of electric light, power, Class 1, non-power-limited fire alarm, or medium power network-powered broadband communications circuits.

Exception No. 1: Where all of the conductors of electric light, power, Class 1, non-power-limited fire alarm, and medium power network-powered broadband communications circuits are separated from all of the coaxial cables by a permanent barrier or listed divider.

Exception No. 2: Power circuit conductors in outlet boxes, junction boxes, or similar fittings or compartments where such conductors are introduced solely for power supply to the coaxial cable system distribution equipment. The power circuit conductors shall be routed within the enclosure to maintain a minimum 6-mm (0.25-in.) separation from coaxial cables.

(2) Other Applications. Coaxial cable shall be separated at least 50 mm (2 in.) from conductors of any electric light, power, Class 1, non-power-limited fire alarm, or medium power network-powered broadband communications circuits.

Exception No. 1: Where either (1) all of the conductors of electric light, power, Class 1, non-power-limited fire alarm, and medium power network-powered broadband communications circuits are in a raceway, or in metal-sheathed, metal-clad, nonmetallic-sheathed Type AC or Type UF cables, or (2) all of the coaxial cables are encased in raceway.

(C) Support of Cables. Raceways shall be used for their intended purpose. Coaxial cables shall not be strapped, taped, or attached by any means to the exterior of any conduit or raceway as a means of support.

Exception: Overhead (aerial) spans of coaxial cables shall be permitted to be attached to the exterior of a raceway-type mast intended for the attachment and support of such cables.

820.154 Applications of Listed CATV Cables and CATV Raceways. CATV cables shall comply with the requirements of 820.154(A), 820.154(B), and 820.154(D) or where cable substitutions are made as shown in Table 820.154.

(A) Plenums. Cables installed in ducts, plenums, and other spaces used for environmental air shall be Type CATVP. Abandoned cables shall not be permitted to remain. Types CATVP, CATVR, CATV, and CATVX cables installed in compliance with 300.22 shall be permitted. Listed plenum CATV raceways shall be permitted to be installed in ducts and plenums as described in 300.22(B) and in other spaces used for environmental air as described in 300.22(C). Only

Table 820.154 Coaxial Cable Uses and Permitted Substitutions

Cable Type	Permitted Substitutions
CATVP	CMP, BLP
CATVR	CATVP, CMP, CMR, BMR, BLP, BLR
CATV	CATVP, CMP, CATVR, CMR, CMG, CM, BMR, BM, BLP, BLR, BL
CATVX	CATVP, CMP, CATVR, CMR, CATV, CMG, CM, BMR, BM, BLP, BLR, BL, BLX

Type CATVP cable shall be permitted to be installed in these raceways.

(B) Riser. Cables installed in risers shall comply with any of the requirements of 820.154(B)(1) through (B)(3).

(1) Cables in Vertical Runs. Cables installed in vertical runs and penetrating more than one floor, or cables installed in vertical runs in a shaft, shall be Type CATVR. Floor penetrations requiring Type CATVR shall contain only cables suitable for riser or plenum use. Abandoned cables shall not be permitted to remain. Listed riser CATV raceways shall be permitted to be installed in vertical riser runs in a shaft from floor to floor. Only Type CATVR and CATVP cables shall be permitted to be installed in these raceways.

(2) Metal Raceways or Fireproof Shafts. Types CATV and CATVX cables shall be permitted to be encased in a metal raceway or located in a fireproof shaft having fire-stops at each floor.

(3) One- and Two-Family Dwellings. Types CATV and CATVX cables shall be permitted in one- and two-family dwellings.

FPN: See 820.3(A) for the firestop requirements for floor penetrations.

(D) Other Wiring Within Buildings. Cables installed in building locations other than the locations covered in 820.154(A) and 820.154(B) shall be with any of the requirements in 820.154(D)(1) through (D)(4). Abandoned cables in hollow spaces shall not be permitted to remain.

(1) General. Type CATV shall be permitted. Listed CATV general-purpose raceways shall be permitted. Only Types CATV, CATVX, CATVR, or CATVP cables shall be permitted to be installed in general-purpose communications raceways.

(2) In Raceways. Type CATVX shall be permitted to be installed in a raceway.

(3) Nonconcealed Spaces. Type CATVX shall be permitted to be installed in nonconcealed spaces where the exposed length of cable does not exceed 3 m (10 ft).

(4) One- and Two-Family Dwellings. Type CATVX cables less than 10 mm (0.375 in.) in diameter shall be permitted to be installed in one- and two-family dwellings.

ARTICLE 830
Network-Powered Broadband
Communications Systems

I. General

830.1 Scope. This article covers network-powered broadband communications systems that provide any combination of voice, audio, video, data, and interactive services through a network interface unit.

FPN No. 1: A typical basic system configuration includes a cable supplying power and broadband signal to a network interface unit that converts the broadband signal to the component signals. Typical cables are coaxial cable with both broadband signal and power on the center conductor, composite metallic cable with a coaxial member for the broadband signal and a twisted pair for power, and composite optical fiber cable with a pair of conductors for power. Larger systems may also include network components such as amplifiers that require network power.

830.2 Definitions. See Article 100. For purposes of this article, the following additional definitions apply.

Abandoned Network-Powered Broadband Communications Cable. Installed network-powered broadband communications cable that is not terminated at equipment other than a connector and not identified for future use with a tag.

Fault Protection Device. An electronic device that is intended for the protection of personnel and functions under fault conditions, such as network-powered broadband communications cable short or open circuit, to limit the current or voltage, or both, for a low-power network-powered broadband communications circuit and provide acceptable protection from electric shock.

Network Interface Unit (NIU). A device that converts a broadband signal into component voice, audio, video, data, and interactive services signals. The NIU provides isolation between the network power and the premises signal circuits. The NIU may also contain primary and secondary protectors.

Network-Powered Broadband Communications Circuit. The circuit extending from the communications utility's serving terminal or tap up to and including the NIU.

FPN: A typical single-family network-powered communications circuit consists of a communications drop or communications service cable and an NIU and includes the communications utility's serving terminal or tap where it is not under the exclusive control of the communications utility.

Point of Entrance. The point within a building at which the cable emerges from an external wall, from a concrete floor slab, or from a rigid metal conduit or an intermediate metal conduit grounded to an electrode in accordance with 830.100(B).

Premises Wiring. The circuits located on the user side of the network interface unit.

830.3 Other Articles. Circuits and equipment shall comply with 830.3(A) through 830.3(D).

(A) Spread of Fire or Products of Combustion. Section 300.21 shall apply. The accessible portion of abandoned network-powered broadband communications cables shall be removed.

(B) Ducts, Plenums, and Other Air-Handling Spaces. Section 300.22 shall apply where installed in ducts, plenums, or other spaces used for environmental air.

Exception: As permitted in 830.154(B).

(C) Equipment in Other Space Used for Environmental Air. Section 300.22(C) shall apply.

(D) Output Circuits. As appropriate for the services provided, the output circuits derived from the network interface unit shall comply with the requirements of the following:

- (1) Installations of communications circuits — Article 800
- (2) Installations of community antenna television and radio distribution circuits — Article 820

Exception: 830.90(B)(3) shall apply where protection is provided in the output of the NIU.

- (3) Installations of optical fiber cables — Article 770 in the *NEC*
- (4) Installations of Class 2 and Class 3 circuits — Article 725
- (5) Installations of power-limited fire alarm circuits — Article 760

830.21 Access to Electrical Equipment Behind Panels Designed to Allow Access. Access to electrical equipment shall not be denied by an accumulation of wires and cables that prevents removal of panels, including suspended ceiling panels.

830.24 Mechanical Execution of Work. Network-powered broadband communications circuits and equipment shall be installed in a neat and workmanlike manner. Cables installed exposed on the surface of ceilings and sidewalls

shall be supported by the building structure in such a manner that the cable will not be damaged by normal building use. Such cables shall be secured by straps, staples, hangers, or similar fittings designed and installed so as not to damage the cable. The installation shall also conform with 300.4(D) and 300.11.

II. Cables Outside and Entering Buildings

830.40 Entrance Cables. Network-powered broadband communications cables located outside and entering buildings shall comply with 830.40(A) and 830.40(B).

(A) Medium Power Circuits. Medium power network-powered broadband communications circuits located outside and entering buildings shall be installed using Type BMU, Type BM, or Type BMR network-powered broadband communications medium power cables.

(B) Low-Power Circuits. Low-power network-powered broadband communications circuits located outside and entering buildings shall be installed using Type BLU or Type BLX low-power network-powered broadband communications cables. Cables shown in Table 830.133 shall be permitted to substitute.

Exception: Outdoor community antenna television and radio distribution system coaxial cables installed prior to January 1, 2000, and installed in accordance with Article 820, shall be permitted for low-power-type, network-powered broadband communications circuits.

830.44 Aerial Cables. Aerial network-powered broadband communications cables shall comply with 830.44(D), (E), (F), (G), and (I).

(D) Clearance from Ground. Overhead spans of network-powered broadband communication cables shall conform to not less than the following:

- (1) 2.9 m (9.5 ft) — above finished grade, sidewalks, or from any platform or projection from which they might be reached and accessible to pedestrians only
- (2) 3.5 m (11.5 ft) — over residential property and driveways, and those commercial areas not subject to truck traffic
- (3) 4.7 m (15.5 ft) — over public streets, alleys, roads, parking areas subject to truck traffic, driveways on other than residential property, and other land traversed by vehicles such as cultivated, grazing, forest, and orchard

(E) Over Pools. Clearance of network-powered broadband communications cable in any direction from the water level, edge of pool, base of diving platform, or anchored raft shall comply with those clearances in 680.8.

(F) Above Roofs. Network-powered broadband communications cables shall have a vertical clearance of not less than 2.5 m (8 ft) from all points of roofs above which they pass.

Exception No. 1: Auxiliary buildings such as garages and the like.

Exception No. 2: A reduction in clearance above only the overhanging portion of the roof to not less than 450 mm (18 in.) shall be permitted if (1) not more than 1.2 m (4 ft) of the broadband communications drop cables pass above the roof overhang, and (2) they are terminated at a through-the-roof raceway or support.

Exception No. 3: Where the roof has a slope of not less than 100 mm in 300 mm (4 in. in 12 in.), a reduction in clearance to not less than 900 mm (3 ft) shall be permitted.

(G) Final Spans. Final spans of network-powered broadband communications cables without an outer jacket shall be permitted to be attached to the building, but they shall be kept not less than 900 mm (3 ft) from windows that are designed to be opened, doors, porches, balconies, ladders, stairs, fire escapes, or similar locations.

Exception: Conductors run above the top level of a window shall be permitted to be less than the 900-mm (3-ft) requirement above.

(I) On Buildings. Where attached to buildings, network-powered broadband communications cables shall be securely fastened in such a manner that they are separated from other conductors in accordance with 830.44(I)(3) and (I)(4).

(3) Lightning Conductors. Where practicable, a separation of at least 1.8 m (6 ft) shall be maintained between any network-powered broadband communications cable and lightning conductors.

(4) Protection from Damage. Network-powered broadband communications cables attached to buildings and located within 2.5 m (8 ft) of finished grade shall be protected by enclosures, raceways, or other approved means.

Exception: A low-power network-powered broadband communications circuit that is equipped with a listed fault protection device, appropriate to the network-powered broadband communications cable used, and located on the network side of the network-powered broadband communications cable being protected.

830.47 Underground Circuits Entering Buildings.

(B) Direct-Buried Cables and Raceways. Direct-buried network-powered broadband communications cables shall be separated at least 300 mm (12 in.) from conductors of

any light, power, non-power-limited fire alarm circuit conductors or Class 1 circuit.

Exception No. 1: Where electric service conductors or network-powered broadband communications cables are installed in raceways or have metal cable armor.

Exception No. 2: Where electric light or power branch-circuit or feeder conductors, non-power-limited fire alarm circuit conductors, or Class 1 circuit conductors are installed in a raceway or in metal-sheathed, metal-clad, or Type UF or Type USE cables; or the network-powered broadband communications cables have metal cable armor or are installed in a raceway.

(C) Mechanical Protection. Direct-buried cable, conduit, or other raceways shall be installed to meet the minimum cover requirements of Table 830.47. In addition, direct-buried cables emerging from the ground shall be protected by enclosures, raceways, or other approved means extending from the minimum cover distance required by Table 830.47 below grade to a point at least 2.5 m (8 ft) above finished grade. In no case shall the protection be required to exceed 450 mm (18 in.) below finished grade. Type BMU and BLU direct-buried cables emerging from the ground shall be installed in rigid metal conduit, intermediate metal conduit, rigid nonmetallic conduit, or other approved means extending from the minimum cover distance required by Table 830.47 below grade to the point of entrance.

Exception: A low-power network-powered broadband communications circuit that is equipped with a listed fault protection device, appropriate to the network-powered broadband communications cable used, and located on the network side of the network-powered broadband communications cable being protected.

(D) Pools. Cables located under the pool or within the area extending 1.5 m (5 ft) horizontally from the inside wall of the pool shall meet those clearances and requirements specified in 680.10.

III. Protection

830.90 Primary Electrical Protection.

(A) Application. Primary electrical protection shall be provided on all network-powered broadband communications conductors that are neither grounded nor interrupted and are run partly or entirely in aerial cable not confined within a block. Also, primary electrical protection shall be provided on all aerial or underground network-powered broadband communications conductors that are neither grounded nor interrupted and are located within the block containing the building served so as to be exposed to lightning or accidental contact with electric light or power conductors operating at over 300 volts to ground.

Exception: Where electrical protection is provided on the derived circuit(s) (output side of the NIU) in accordance with 830.90(B)(3).

(B) Location. The location of the primary protector, where required, shall comply with (B)(1), (B)(2), or (B)(3):

- (1) A listed primary protector shall be applied on each network-powered broadband communications cable external to and on the network side of the network interface unit.
- (2) The primary protector function shall be an integral part of and contained in the network interface unit. The network interface unit shall be listed as being suitable for application with network-powered broadband communications systems and shall have an external marking indicating that it contains primary electrical protection.
- (3) The primary protector(s) shall be provided on the derived circuit(s) (output side of the NIU), and the combination of the NIU and the protector(s) shall be listed as being suitable for application with network-powered broadband communications systems.

A primary protector, whether provided integrally or external to the network interface unit, shall be located as close as practicable to the point of entrance.

For purposes of this section, a network interface unit and any externally provided primary protectors located at mobile home service equipment located in sight from and not more than 9.0 m (30 ft) from the exterior wall of the mobile home it serves, or at a mobile home disconnecting means grounded in accordance with 250.32 and located in sight from and not more than 9.0 m (30 ft) from the exterior wall of the mobile home it serves, shall be considered to meet the requirements of this section.

FPN: Selecting a network interface unit and primary protector location to achieve the shortest practicable primary protector grounding conductor helps limit potential differences between communications circuits and other metallic systems.

830.93 Grounding or Interruption of Metallic Members of Network-Powered Broadband Communications Cables.

The shields of network-powered broadband communications cables used for communications or powering shall be grounded at the building as close as practicable to the point of entrance or attachment of the NIU. Metallic cable members not used for communications or powering shall be grounded or interrupted by an insulating joint or equivalent device as close as practicable to the point of entrance or attachment of the NIU.

For purposes of this section, grounding or interruption of network-powered broadband communications cable metallic members installed at mobile home service equipment located in sight from and no more than 9.0 m (30 ft) from the

Table 830.47 Network-Powered Broadband Communications Systems Minimum Cover Requirements (*Cover* is the shortest distance measured between a point on the top surface of any direct-buried cable, conduit, or other raceway and the top surface of finished grade, concrete, or similar cover.)

Location of Wiring Method or Circuit	Direct Burial Cables		Rigid Metal Conduit or Intermediate Metal Conduit		Nonmetallic Raceways Listed for Direct Burial; Without Concrete Encasement or Other Approved Raceways	
	mm	in.	mm	in.	mm	in.
All locations not specified below	450	18	150	6	300	12
In trench below 50-mm (2-in.) thick concrete or equivalent	300	12	150	6	150	6
Under a building (in raceway only)	0	0	0	0	0	0
Under minimum of 100-mm (4-in.) thick concrete exterior slab with no vehicular traffic and the slab extending not less than 150 mm (6 in.) beyond the underground installation	300	12	100	4	100	4
One- and two-family dwelling driveways and outdoor parking areas and used only for dwelling-related purposes	300	12	300	12	300	12

Notes:

1. Raceways approved for burial only where concrete encased shall require a concrete envelope not less than 50 mm (2 in.) thick.
2. Lesser depths shall be permitted where cables rise for terminations or splices or where access is otherwise required.
3. Where solid rock is encountered, all wiring shall be installed in metal or nonmetallic raceway permitted for direct burial. The raceways shall be covered by a minimum of 50 mm (2 in.) of concrete extending down to rock.
4. Low-power network-powered broadband communications circuits using directly buried community antenna television and radio distribution system coaxial cables that were installed outside and entering buildings prior to January 1, 2000, in accordance with Article 820 shall be permitted where buried to a minimum depth of 300 mm (12 in.).

exterior wall of the mobile home it serves, or at a mobile home disconnecting means grounded in accordance with 250.32 and located in sight from and not more than 9.0 m (30 ft) from the exterior wall of the mobile home it serves, shall be considered to meet the requirements of this section.

FPN: Selecting a grounding location to achieve the shortest practicable grounding conductor helps limit potential differences between the network-powered broadband communications circuits and other metallic systems.

IV. Grounding Methods

830.100 Cable, Network Interface Unit, and Primary Protector Grounding. Network interface units containing

protectors, NIUs with metallic enclosures, primary protectors, and the metallic members of the network-powered broadband communications cable that are intended to be grounded shall be grounded as specified in 830.100(A) through 830.100(D).

(A) Grounding Conductor.

(1) **Insulation.** The grounding conductor shall be insulated and shall be listed as suitable for the purpose.

(2) **Material.** The grounding conductor shall be copper or other corrosion-resistant conductive material, stranded or solid.

(3) Size. The grounding conductor shall not be smaller than 14 AWG and shall have a current-carrying capacity approximately equal to that of the grounded metallic member(s) and protected conductor(s) of the network-powered broadband communications cable. The grounding conductor shall not be required to exceed 6 AWG.

(4) Length. The grounding conductor shall be as short as practicable. In one-family and multifamily dwellings, the grounding conductor shall be as short as permissible, not to exceed 6.0 m (20 ft) in length.

Exception: In one- and two-family dwellings where it is not practicable to achieve an overall maximum grounding conductor length of 6.0 m (20 ft), a separate communications ground rod meeting the minimum dimensional criteria of 830.100(B)(2)(2) shall be driven, and the grounding conductor shall be connected to the communications ground rod in accordance with 830.100(C). The communications ground rod shall be bonded to the power grounding electrode system in accordance with 830.100(D).

(5) Run in Straight Line. The grounding conductor shall be run to the grounding electrode in as straight a line as practicable.

(6) Physical Protection. Where subject to physical damage, the grounding conductor shall be adequately protected. Where the grounding conductor is run in a metal raceway, both ends of the raceway shall be bonded to the grounding conductor or the same terminal or electrode to which the grounding conductor is connected.

(B) Electrode. The grounding conductor shall be connected as follows.

(1) In Buildings or Structures with Grounding Means. To the nearest accessible location on the following:

- (1) The building or structure grounding electrode system as covered in 250.50
- (2) The grounded interior metal water piping system, within 1.5 m (5 ft) from its point of entrance to the building, as covered in 250.52
- (3) The power service accessible means external to enclosures as covered in 250.94
- (4) The metallic power service raceway
- (5) The service equipment enclosure
- (6) The grounding electrode conductor or the grounding electrode metal enclosure, or
- (7) The grounding conductor or the grounding electrode of a building or structure disconnecting means that is grounded to an electrode as covered in 250.32

For purposes of this section, the mobile home service equipment or the mobile home disconnecting means, as described in 830.93, shall be considered accessible.

(2) In Buildings or Structures Without Grounding Means. If the building or structure served has no grounding means, as described in (B)(1), the grounding conductor shall be connected to either of the following:

- (1) To any one of the individual electrodes described in 250.52(A)(1), (A)(2), (A)(3), or (A)(4)
- (2) If the building or structure served has no grounding means, as described in 830.100(B)(1) or (B)(2)(1), to an effectively grounded metal structure or to a ground rod or pipe not less than 1.5 m (5 ft) in length and 12.7 mm (½ in.) in diameter, driven, where practicable, into permanently damp earth and separated from lightning conductors as covered in 800.53 in the *NEC* and at least 1.8 m (6 ft) from electrodes of other systems. Steam or hot water pipes or lightning-rod conductors shall not be employed as electrodes for protectors, NIUs with integral protection, grounded metallic members, NIUs with metallic enclosures, and other equipment.

(C) Electrode Connection. Connections to grounding electrodes shall comply with 250.70.

(D) Bonding of Electrodes. A bonding jumper not smaller than 6 AWG copper or equivalent shall be connected between the network-powered broadband communications system grounding electrode and the power grounding electrode system at the building or structure served where separate electrodes are used.

Exception: At mobile homes as covered in 830.106.

FPN No. 1: See 250.60 for use of lightning rods.

FPN No. 2: Bonding together of all separate electrodes limits potential differences between them and between their associated wiring systems.

830.106 Bonding and Grounding at Mobile Homes.

(A) Grounding. Where there is no mobile home service equipment located in sight from and not more than 9.0 m (30 ft) from the exterior wall of the mobile home it serves, or there is no mobile home disconnecting means grounded in accordance with 250.32 and located within sight from and not more than 9.0 m (30 ft) from the exterior wall of the mobile home it serves, the network-powered broadband communications cable, network interface unit, and primary protector ground shall be installed in accordance with 830.100(B)(2).

(B) Bonding. The network-powered broadband communications cable grounding terminal, network interface unit grounding terminal, if present, and primary protector grounding terminal shall be bonded together with a copper bonding conductor not smaller than 12 AWG. The network-powered broadband communications cable grounding termi-

nal, network interface unit grounding terminal, primary protector grounding terminal, or the grounding electrode shall be bonded to the metal frame or available grounding terminal of the mobile home with a copper bonding conductor not smaller than 12 AWG under any of the following conditions:

- (1) Where there is no mobile home service equipment or disconnecting means as in 830.106(A)
- (2) Where the mobile home is supplied by cord and plug

V. Wiring Methods Within Buildings

830.133 Installation of Network-Powered Broadband Communications Cables and Equipment. Cable and equipment installations within buildings shall comply with 830.133(A) through 830.133(D), as applicable.

(A) Separation of Conductors.

(1) In Raceways and Enclosures.

(a) Low and Medium Power Network-Powered Broadband Communications Circuit Cables. Low and medium power network-powered broadband communications cables shall be permitted in the same raceway or enclosure.

(b) Low-Power Network-Powered Broadband Communications Circuit Cables. Low-power network-powered broadband communications cables shall be permitted in the same raceway or enclosure with jacketed cables of any of the following circuits:

- (1) Class 2 and Class 3 remote-control, signaling, and power-limited circuits in compliance with Article 725
- (2) Power-limited fire alarm systems in compliance with Article 760
- (3) Communications circuits in compliance with Article 800
- (4) Nonconductive and conductive optical fiber cables in compliance with Article 770 in the *NEC*
- (5) Community antenna television and radio distribution systems in compliance with Article 820

(c) Medium Power Network-Powered Broadband Communications Circuit Cables. Medium power network-powered broadband communications cables shall not be permitted in the same raceway or enclosure with conductors of any of the following circuits:

- (1) Class 2 and Class 3 remote-control, signaling, and power-limited circuits in compliance with Article 725
- (2) Power-limited fire alarm systems in compliance with Article 760
- (3) Communications circuits in compliance with Article 800
- (4) Conductive optical fiber cables in compliance with Article 770 in the *NEC*

- (5) Community antenna television and radio distribution systems in compliance with Article 820

(d) Electric Light, Power, Class 1, Non-Powered Broadband Communications Circuit Cables. Network-powered broadband communications cable shall not be placed in any raceway, compartment, outlet box, junction box, or similar fittings with conductors of electric light, power, Class 1, or non-power-limited fire alarm circuit cables.

Exception No. 1: Where all of the conductors of electric light, power, Class 1, non-power-limited fire alarm circuits are separated from all of the network-powered broadband communications cables by a permanent barrier or listed divider.

Exception No. 2: Power circuit conductors in outlet boxes, junction boxes, or similar fittings or compartments where such conductors are introduced solely for power supply to the network-powered broadband communications system distribution equipment. The power circuit conductors shall be routed within the enclosure to maintain a minimum 6-mm (0.25-in.) separation from network-powered broadband communications cables.

(2) Other Applications. Network-powered broadband communications cable shall be separated at least 50 mm (2 in.) from conductors of any electric light, power, Class 1, and non-power-limited fire alarm circuits.

Exception No. 1: Where either (1) all of the conductors of electric light, power, Class 1, and non-power-limited fire alarm circuits are in a raceway, or in metal-sheathed, metal-clad, nonmetallic-sheathed, Type AC, or Type UF cables, or (2) all of the network-powered broadband communications cables are encased in raceway.

(B) Support of Conductors. Raceways shall be used for their intended purpose. Network-powered broadband communications cables shall not be strapped, taped, or attached by any means to the exterior of any conduit or raceway as a means of support.

(C) Cable Substitutions. The substitutions for network-powered broadband cables listed in Table 830.133 shall be permitted. All cables in Table 830.133, other than network-powered broadband cables, shall be coaxial cables.

(D) Installation and Use. Section 110.3(B) shall apply.

830.151 Medium Power Network-Powered Broadband Communications System Wiring Methods. Medium power network-powered broadband communications systems shall be installed within buildings using listed Type BM or Type BMR, network-powered broadband communications medium power cables.

Table 830.133 Cable Substitutions

Cable Type	Permitted Cable Substitutions
BM	BMR
BLP	CMP, CL3P
BLR	CMP, CL3P, CMR, CL3R, BLP, BMR
BL	CMP, CMR, CM, CMG, CL3P, CL3R, CL3, BMR, BM, BLP, BLR
BLX	CMP, CMR, CM, CMG, CMX, CL3P, CL3R, CL3, CL3X, BMR, BM, BLP, BRP, BL

(A) Ducts, Plenums, and Other Air-Handling Spaces. Section 300.22 shall apply.

(B) Riser. Cables installed in vertical runs and penetrating more than one floor, or cables installed in vertical runs in a shaft, shall be Type BMR. Floor penetrations requiring Type BMR shall contain only cables suitable for riser or plenum use.

Exception No. 1: Type BM cables encased in metal raceway or located in a fireproof shaft that has firestops at each floor.

Exception No. 2: Type BM cables in one- and two-family dwellings.

(C) Other Wiring. Cables installed in locations other than the locations covered in 830.151(A) and 830.151(B) shall be Type BM.

Exception: Type BMU cable where the cable enters the building from the outside and is run in rigid metal conduit or intermediate metal conduit, and such conduits are grounded to an electrode in accordance with 830.100(B).

830.154 Low-Power Network-Powered Broadband Communications System Wiring Methods. Low-power network-powered broadband communications systems shall comply with any of the requirements of 830.154(A) through 830.154(D).

(A) In Buildings. Low-power network-powered broadband communications systems shall be installed within buildings using listed Type BLX, Type BL, Type BLR, or Type BLP network-powered broadband communications low-power cables.

(B) Ducts, Plenums, and Other Air-Handling Spaces. Cables installed in ducts, plenums, and other spaces used for environmental air shall be Type BLP. Type BLX cable installed in compliance with 300.22 shall be permitted.

(C) Riser. Cables installed in risers shall comply with any of the requirements in 830.154(C)(1), (C)(2), or (C)(3).

(1) Cables in Vertical Runs. Cables installed in vertical runs and penetrating more than one floor, or cables installed in vertical runs in a shaft, shall be Type BLP, BLR, or BMR. Floor penetrations requiring Type BMR or BLR shall contain only cables suitable for riser or plenum use.

(2) Metal Raceways or Fireproof Shafts. Type BLX cables shall be permitted to be encased in a metal raceway or located in a fireproof shaft having firestops at each floor.

(3) One- and Two-Family Dwellings. Type BLX or BL cables less than 10 mm (0.375 in.) in diameter shall be permitted in one- and two-family dwellings.

(D) Other Wiring. Cables installed in locations other than those covered in 830.154(A), (B), and (C) shall comply with the requirements of 830.154(D)(1) through (D)(5).

(1) General. Type BLP, BL, or BM shall be permitted.

(2) In Raceways. Type BLX shall be permitted to be installed in a raceway.

(3) Type BLU Cable. Type BLU cable entering the building from outside shall be permitted to be run in rigid metal conduit or intermediate metal conduit. Such conduits shall be grounded to an electrode in accordance with 830.100(B).

(4) One- and Two-Family Dwellings. Type BLX or BL cables less than 10 mm (0.375 in.) in diameter shall be permitted to be installed in one- and two-family dwellings.

(5) Type BLX Cable. Type BLX cable entering the building from outside and terminated at a grounding block or a primary protection location shall be permitted to be installed, provided that the length of cable within the building does not exceed 15 m (50 ft).

FPN: This provision limits the length of Type BLX cable to 15 m (50 ft), while 830.90(B) requires that the primary protector, or NIU with integral protection, be located as close as practicable to the point at which the cable enters the building. Therefore, in installations requiring a primary protector, or NIU with integral protection, Type BLX cable may not be permitted to extend 15 m (50 ft) into the building if it is practicable to place the primary protector closer than 15 m (50 ft) to the entrance point.

830.157 Protection Against Physical Damage. Section 300.4 shall apply.

830.160 Bends. Bends in network broadband cable shall be made so as not to damage the cable.

Chapter 9 Tables

Table 1 Percent of Cross Section of Conduit and Tubing for Conductors

Number of Conductors	All Conductor Types
1	53
2	31
Over 2	40

FPN No. 1: Table 1 is based on common conditions of proper cabling and alignment of conductors where the length of the pull and the number of bends are within reasonable limits. It should be recognized that, for certain conditions, a larger size conduit or a lesser conduit fill should be considered.

FPN No. 2: When pulling three conductors or cables into a raceway, if the ratio of the raceway (inside diameter) to the conductor or cable (outside diameter) is between 2.8 and 3.2, jamming can occur. While jamming can occur when pulling four or more conductors or cables into a raceway, the probability is very low.

Notes to Tables

- (1) See Annex C for the maximum number of conductors and fixture wires, all of the same size (total cross-sectional area including insulation) permitted in trade sizes of the applicable conduit or tubing.
- (2) Table 1 applies only to complete conduit or tubing systems and is not intended to apply to sections of conduit or tubing used to protect exposed wiring from physical damage.
- (3) Equipment grounding or bonding conductors, where installed, shall be included when calculating conduit or

tubing fill. The actual dimensions of the equipment grounding or bonding conductor (insulated or bare) shall be used in the calculation.

- (4) Where conduit or tubing nipples having a maximum length not to exceed 600 mm (24 in.) are installed between boxes, cabinets, and similar enclosures, the nipples shall be permitted to be filled to 60 percent of their total cross-sectional area, and 310.15(B)(2)(a) adjustment factors need not apply to this condition.
- (5) For conductors not included in Chapter 9, such as multi-conductor cables, the actual dimensions shall be used.
- (6) For combinations of conductors of different sizes, use Table 5 and Table 5A for dimensions of conductors and Table 4 for the applicable conduit or tubing dimensions.
- (7) When calculating the maximum number of conductors permitted in a conduit or tubing, all of the same size (total cross-sectional area including insulation), the next higher whole number shall be used to determine the maximum number of conductors permitted when the calculation results in a decimal of 0.8 or larger.
- (8) Where bare conductors are permitted by other sections of this *Code*, the dimensions for bare conductors in Table 8 shall be permitted.
- (9) A multiconductor cable of two or more conductors shall be treated as a single conductor for calculating percentage conduit fill area. For cables that have elliptical cross sections, the cross-sectional area calculation shall be based on using the major diameter of the ellipse as a circle diameter.

Table 2 Radius of Conduit and Tubing Bends

Conduit or Tubing Size		One Shot and Full Shoe Benders		Other Bends	
Metric Designator	Trade Size	mm	in.	mm	in.
16	½	101.6	4	101.6	4
21	¾	114.3	4½	127	5
27	1	146.05	5¾	152.4	6
35	1¼	184.15	7¼	203.2	8
41	1½	209.55	8¼	254	10
53	2	241.3	9½	304.8	12
63	2½	266.7	10½	381	15
78		330.2	13	457.2	18
91	3½	381	15	533.4	21
103	4	406.4	16	609.6	24
129	5	609.6	24	762	30
155	6	762	30	914.4	36

Table 4 Dimensions and Percent Area of Conduit and Tubing (Areas of Conduit or Tubing for the Combinations of Wires Permitted in Table 1, Chapter 9)

Article 358 — Electrical Metallic Tubing (EMT)													
Metric Designator	Trade Size	Nominal Internal Diameter		Total Area 100%		60%		1 Wire 53%		2 Wires 31%		Over 2 Wires 40%	
		mm	in.	mm ²	in. ²	mm ²	in. ²	mm ²	in. ²	mm ²	in. ²	mm ²	in. ²
16	½	15.8	0.622	196	0.304	118	0.182	104	0.161	61	0.094	78	0.122
21	¾	20.9	0.824	343	0.533	206	0.320	182	0.283	106	0.165	137	0.213
27	1	26.6	1.049	556	0.864	333	0.519	295	0.458	172	0.268	222	0.346
35	1¼	35.1	1.380	968	1.496	581	0.897	513	0.793	300	0.464	387	0.598
41	1½	40.9	1.610	1314	2.036	788	1.221	696	1.079	407	0.631	526	0.814
53	2	52.5	2.067	2165	3.356	1299	2.013	1147	1.778	671	1.040	866	1.342
63	2½	69.4	2.731	3783	5.858	2270	3.515	2005	3.105	1173	1.816	1513	2.343
78	3	85.2	3.356	5701	8.846	3421	5.307	3022	4.688	1767	2.742	2280	3.538
91	3½	97.4	3.834	7451	11.545	4471	6.927	3949	6.119	2310	3.579	2980	4.618
103	4	110.1	4.334	9521	14.753	5712	8.852	5046	7.819	2951	4.573	3808	5.901

Article 362 — Electrical Nonmetallic Tubing (ENT)													
Metric Designator	Trade Size	Nominal Internal Diameter		Total Area 100%		60%		1 Wire 53%		2 Wires 31%		Over 2 Wires 40%	
		mm	in.	mm ²	in. ²	mm ²	in. ²	mm ²	in. ²	mm ²	in. ²	mm ²	in. ²
16	½	14.2	0.560	158	0.246	95	0.148	84	0.131	49	0.076	63	0.099
21	¾	19.3	0.760	293	0.454	176	0.272	155	0.240	91	0.141	117	0.181
27	1	25.4	1.000	507	0.785	304	0.471	269	0.416	157	0.243	203	0.314
35	1¼	34.0	1.340	908	1.410	545	0.846	481	0.747	281	0.437	363	0.564
41	1½	39.9	1.570	1250	1.936	750	1.162	663	1.026	388	0.600	500	0.774
53	2	51.3	2.020	2067	3.205	1240	1.923	1095	1.699	641	0.993	827	1.282
63	2½	—	—	—	—	—	—	—	—	—	—	—	—
78	3	—	—	—	—	—	—	—	—	—	—	—	—
91	3½	—	—	—	—	—	—	—	—	—	—	—	—

Article 348 — Flexible Metal Conduit (FMC)													
Metric Designator	Trade Size	Nominal Internal Diameter		Total Area 100%		60%		1 Wire 53%		2 Wires 31%		Over 2 Wires 40%	
		mm	in.	mm ²	in. ²	mm ²	in. ²	mm ²	in. ²	mm ²	in. ²	mm ²	in. ²
12	⅜	9.7	0.384	74	0.116	44	0.069	39	0.061	23	0.036	30	0.046
16	½	16.1	0.635	204	0.317	122	0.190	108	0.168	63	0.098	81	0.127
21	¾	20.9	0.824	343	0.533	206	0.320	182	0.283	106	0.165	137	0.213
27	1	25.9	1.020	527	0.817	316	0.490	279	0.433	163	0.253	211	0.327
35	1¼	32.4	1.275	824	1.277	495	0.766	437	0.677	256	0.396	330	0.511
41	1½	39.1	1.538	1201	1.858	720	1.115	636	0.985	372	0.576	480	0.743
53	2	51.8	2.040	2107	3.269	1264	1.961	1117	1.732	653	1.013	843	1.307
63	2½	63.5	2.500	3167	4.909	1900	2.945	1678	2.602	982	1.522	1267	1.963
78	3	76.2	3.000	4560	7.069	2736	4.241	2417	3.746	1414	2.191	1824	2.827
91	3½	88.9	3.500	6207	9.621	3724	5.773	3290	5.099	1924	2.983	2483	3.848
103	4	101.6	4.000	8107	12.566	4864	7.540	4297	6.660	2513	3.896	3243	5.027

Article 342 — Intermediate Metal Conduit (IMC)

Metric Designator	Trade Size	Nominal Internal Diameter		Total Area 100%		60%		1 Wire 53%		2 Wires 31%		Over 2 Wires 40%	
		mm	in.	mm ²	in. ²	mm ²	in. ²	mm ²	in. ²	mm ²	in. ²	mm ²	in. ²
12	3/8	—	—	—	—	—	—	—	—	—	—	—	—
16	1/2	16.8	0.660	222	0.342	133	0.205	117	0.181	69	0.106	89	0.137
21	3/4	21.9	0.864	377	0.586	226	0.352	200	0.311	117	0.182	151	0.235
27	1	28.1	1.105	620	0.959	372	0.575	329	0.508	192	0.297	248	0.384
35	1 1/4	36.8	1.448	1064	1.647	638	0.988	564	0.873	330	0.510	425	0.659
41	1 1/2	42.7	1.683	1432	2.225	859	1.335	759	1.179	444	0.690	573	0.890
53	2	54.6	2.150	2341	3.630	1405	2.178	1241	1.924	726	1.125	937	1.452
63	2 1/2	64.9	2.557	3308	5.135	1985	3.081	1753	2.722	1026	1.592	1323	2.054
78	3	80.7	3.176	5115	7.922	3069	4.753	2711	4.199	1586	2.456	2046	3.169
91	3 1/2	93.2	3.671	6822	10.584	4093	6.351	3616	5.610	2115	3.281	2729	4.234
103	4	105.4	4.166	8725	13.631	5235	8.179	4624	7.224	2705	4.226	3490	5.452

Article 356 — Liquidtight Flexible Nonmetallic Conduit (LFNC-B*)

Metric Designator	Trade Size	Nominal Internal Diameter		Total Area 100%		60%		1 Wire 53%		2 Wires 31%		Over 2 Wires 40%	
		mm	in.	mm ²	in. ²	mm ²	in. ²	mm ²	in. ²	mm ²	in. ²	mm ²	in. ²
12	3/8	12.5	0.494	123	0.192	74	0.115	65	0.102	38	0.059	49	0.077
16	1/2	16.1	0.632	204	0.314	122	0.188	108	0.166	63	0.097	81	0.125
21	3/4	21.1	0.830	350	0.541	210	0.325	185	0.287	108	0.168	140	0.216
27	1	26.8	1.054	564	0.873	338	0.524	299	0.462	175	0.270	226	0.349
35	1 1/4	35.4	1.395	984	1.528	591	0.917	522	0.810	305	0.474	394	0.611
41	1 1/2	40.3	1.588	1276	1.981	765	1.188	676	1.050	395	0.614	510	0.792
53	2	51.6	2.033	2091	3.246	1255	1.948	1108	1.720	648	1.006	836	1.298

*Corresponds to 356.2(2)

Article 356 — Liquidtight Flexible Nonmetallic Conduit (LFNC-A*)

Metric Designator	Trade Size	Nominal Internal Diameter		Total Area 100%		60%		1 Wire 53%		2 Wires 31%		Over 2 Wires 40%	
		mm	in.	mm ²	in. ²	mm ²	in. ²	mm ²	in. ²	mm ²	in. ²	mm ²	in. ²
12	3/8	12.6	0.495	125	0.192	75	0.115	66	0.102	39	0.060	50	0.077
16	1/2	16.0	0.630	201	0.312	121	0.187	107	0.165	62	0.097	80	0.125
21	3/4	21.0	0.825	346	0.535	208	0.321	184	0.283	107	0.166	139	0.214
27	1	26.5	1.043	552	0.854	331	0.513	292	0.453	171	0.265	221	0.342
35	1 1/4	35.1	1.383	968	1.502	581	0.901	513	0.796	300	0.466	387	0.601
41	1 1/2	40.7	1.603	1301	2.018	781	1.211	690	1.070	403	0.626	520	0.807
53	2	52.4	2.063	2157	3.343	1294	2.006	1143	1.772	669	1.036	863	1.337

*Corresponds to 356.2(1)

Article 350 — Liquidtight Flexible Metal Conduit (LFMC)

Metric Designator	Trade Size	Nominal Internal Diameter		Total Area 100%		60%		1 Wire 53%		2 Wires 31%		Over 2 Wires 40%	
		mm	in.	mm ²	in. ²	mm ²	in. ²	mm ²	in. ²	mm ²	in. ²	mm ²	in. ²
12	3/8	12.5	0.494	123	0.192	74	0.115	65	0.102	38	0.059	49	0.077
16	1/2	16.1	0.632	204	0.314	122	0.188	108	0.166	63	0.097	81	0.125
21	3/4	21.1	0.830	350	0.541	210	0.325	185	0.287	108	0.168	140	0.216
27	1	26.8	1.054	564	0.873	338	0.524	299	0.462	175	0.270	226	0.349
35	1 1/4	35.4	1.395	984	1.528	591	0.917	522	0.810	305	0.474	394	0.611
41	1 1/2	40.3	1.588	1276	1.981	765	1.188	676	1.050	395	0.614	510	0.792
53	2	51.6	2.033	2091	3.246	1255	1.948	1108	1.720	648	1.006	836	1.298
63	2 1/2	63.3	2.493	3147	4.881	1888	2.929	1668	2.587	976	1.513	1259	1.953
78	3	78.4	3.085	4827	7.475	2896	4.485	2559	3.962	1497	2.317	1931	2.990
91	3 1/2	89.4	3.520	6277	9.731	3766	5.839	3327	5.158	1946	3.017	2511	3.893
103	4	102.1	4.020	8187	12.692	4912	7.615	4339	6.727	2538	3.935	3275	5.077
129	5	—	—	—	—	—	—	—	—	—	—	—	—
155	6	—	—	—	—	—	—	—	—	—	—	—	—

Article 344 — Rigid Metal Conduit (RMC)

Metric Designator	Trade Size	Nominal Internal Diameter		Total Area 100%		60%		1 Wire 53%		2 Wires 31%		Over 2 Wires 40%	
		mm	in.	mm ²	in. ²	mm ²	in. ²	mm ²	in. ²	mm ²	in. ²	mm ²	in. ²
12	3/8	—	—	—	—	—	—	—	—	—	—	—	—
16	1/2	16.1	0.632	204	0.314	122	0.188	108	0.166	63	0.097	81	0.125
21	3/4	21.2	0.836	353	0.549	212	0.329	187	0.291	109	0.170	141	0.220
27	1	27.0	1.063	573	0.887	344	0.532	303	0.470	177	0.275	229	0.355
35	1 1/4	35.4	1.394	984	1.526	591	0.916	522	0.809	305	0.473	394	0.610
41	1 1/2	41.2	1.624	1333	2.071	800	1.243	707	1.098	413	0.642	533	0.829
53	2	52.9	2.083	2198	3.408	1319	2.045	1165	1.806	681	1.056	879	1.363
63	2 1/2	63.2	2.489	3137	4.866	1882	2.919	1663	2.579	972	1.508	1255	1.946
78	3	78.5	3.090	4840	7.499	2904	4.499	2565	3.974	1500	2.325	1936	3.000
91	3 1/2	90.7	3.570	6461	10.010	3877	6.006	3424	5.305	2003	3.103	2584	4.004
103	4	102.9	4.050	8316	12.882	4990	7.729	4408	6.828	2578	3.994	3326	5.153
129	5	128.9	5.073	13050	20.212	7830	12.127	6916	10.713	4045	6.266	5220	8.085
155	6	154.8	6.093	18821	29.158	11292	17.495	9975	15.454	5834	9.039	7528	11.663

Article 352 — Rigid PVC Conduit (RNC), Schedule 80

Metric Designator	Trade Size	Nominal Internal Diameter		Total Area 100%		60%		1 Wire 53%		2 Wires 31%		Over 2 Wires 40%	
		mm	in.	mm ²	in. ²	mm ²	in. ²	mm ²	in. ²	mm ²	in. ²	mm ²	in. ²
12	3/8	—	—	—	—	—	—	—	—	—	—	—	—
16	1/2	13.4	0.526	141	0.217	85	0.130	75	0.115	44	0.067	56	0.087
21	3/4	18.3	0.722	263	0.409	158	0.246	139	0.217	82	0.127	105	0.164
27	1	23.8	0.936	445	0.688	267	0.413	236	0.365	138	0.213	178	0.275
35	1 1/4	31.9	1.255	799	1.237	480	0.742	424	0.656	248	0.383	320	0.495
41	1 1/2	37.5	1.476	1104	1.711	663	1.027	585	0.907	342	0.530	442	0.684
53	2	48.6	1.913	1855	2.874	1113	1.725	983	1.523	575	0.891	742	1.150
63	2 1/2	58.2	2.290	2660	4.119	1596	2.471	1410	2.183	825	1.277	1064	1.647
78	3	72.7	2.864	4151	6.442	2491	3.865	2200	3.414	1287	1.997	1660	2.577
91	3 1/2	84.5	3.326	5608	8.688	3365	5.213	2972	4.605	1738	2.693	2243	3.475
103	4	96.2	3.786	7268	11.258	4361	6.755	3852	5.967	2253	3.490	2907	4.503
129	5	121.1	4.768	11518	17.855	6911	10.713	6105	9.463	3571	5.535	4607	7.142
155	6	145.0	5.709	16513	25.598	9908	15.359	8752	13.567	5119	7.935	6605	10.239

Articles 352 and 353 — Rigid PVC Conduit (RNC), Schedule 40, and HDPE Conduit

Metric Designator	Trade Size	Nominal Internal Diameter		Total Area 100%		60%		1 Wire 53%		2 Wires 31%		Over 2 Wires 40%	
		mm	in.	mm ²	in. ²	mm ²	in. ²	mm ²	in. ²	mm ²	in. ²	mm ²	in. ²
12	3/8	—	—	—	—	—	—	—	—	—	—	—	—
16	1/2	15.3	0.602	184	0.285	110	0.171	97	0.151	57	0.088	74	0.114
21	3/4	20.4	0.804	327	0.508	196	0.305	173	0.269	101	0.157	131	0.203
27	1	26.1	1.029	535	0.832	321	0.499	284	0.441	166	0.258	214	0.333
35	1 1/4	34.5	1.360	935	1.453	561	0.872	495	0.770	290	0.450	374	0.581
41	1 1/2	40.4	1.590	1282	1.986	769	1.191	679	1.052	397	0.616	513	0.794
53	2	52.0	2.047	2124	3.291	1274	1.975	1126	1.744	658	1.020	849	1.316
63	2 1/2	62.1	2.445	3029	4.695	1817	2.817	1605	2.488	939	1.455	1212	1.878
78	3	77.3	3.042	4693	7.268	2816	4.361	2487	3.852	1455	2.253	1877	2.907
91	3 1/2	89.4	3.521	6277	9.737	3766	5.842	3327	5.161	1946	3.018	2511	3.895
103	4	101.5	3.998	8091	12.554	4855	7.532	4288	6.654	2508	3.892	3237	5.022
129	5	127.4	5.016	12748	19.761	7649	11.856	6756	10.473	3952	6.126	5099	7.904
155	6	153.2	6.031	18433	28.567	11060	17.140	9770	15.141	5714	8.856	7373	11.427

Table 5 Dimensions of Insulated Conductors

Type	Size (AWG or kcmil)	Approximate Diameter		Approximate Area	
		mm	in.	mm ²	in. ²
Type: RHH*, RHW*, RHW-2*, RHH, RHW, RHW-2, THHW, THW, THW-2, TW					
RHH, RHW, RHW-2	14	4.902	0.193	18.90	0.0293
	12	5.385	0.212	22.77	0.0353
	10	5.994	0.236	28.19	0.0437
	8	8.280	0.326	53.87	0.0835
	6	9.246	0.364	67.16	0.1041
	4	10.46	0.412	86.00	0.1333
	3	11.18	0.440	98.13	0.1521
	2	11.99	0.472	112.9	0.1750
	1	14.78	0.582	171.6	0.2660
	1/0	15.80	0.622	196.1	0.3039
	2/0	16.97	0.668	226.1	0.3505
	3/0	18.29	0.720	262.7	0.4072
4/0	19.76	0.778	306.7	0.4754	
	250	22.73	0.895	405.9	0.6291
	300	24.13	0.950	457.3	0.7088
	350	25.43	1.001	507.7	0.7870
	400	26.62	1.048	556.5	0.8626
	500	28.78	1.133	650.5	1.0082
	600	31.57	1.243	782.9	1.2135
TW, THHW, THW, THW-2	14	3.378	0.133	8.968	0.0139
TW, THHW, THW, THW-2	12	3.861	0.152	11.68	0.0181
	10	4.470	0.176	15.68	0.0243
	8	5.994	0.236	28.19	0.0437
RHH*, RHW*, RHW-2*	14	4.140	0.163	13.48	0.0209
	12	4.623	0.182	16.77	0.0260

Table 5 Continued

Type	Size (AWG or kcmil)	Approximate Diameter		Approximate Area	
		mm	in.	mm ²	in. ²
Type: RHH*, RHW*, RHW-2*, THHN, THHW, THW, THW-2, THWN, THWN-2					
RHH*, RHW*, RHW-2*	10	5.232	0.206	21.48	0.0333
	8	6.756	0.266	35.87	0.0556
TW, THW, THHW, THW-2, RHH*, RHW*, RHW-2*	6	7.722	0.304	46.84	0.0726
	4	8.941	0.352	62.77	0.0973
	3	9.652	0.380	73.16	0.1134
	2	10.46	0.412	86.00	0.1333
	1	12.50	0.492	122.6	0.1901
	1/0	13.51	0.532	143.4	0.2223
	2/0	14.68	0.578	169.3	0.2624
	3/0	16.00	0.630	201.1	0.3117
	4/0	17.48	0.688	239.9	0.3718
	250	19.43	0.765	296.5	0.4596
300	20.83	0.820	340.7	0.5281	
350	22.12	0.871	384.4	0.5958	
400	23.32	0.918	427.0	0.6619	
500	25.48	1.003	509.7	0.7901	
600	28.27	1.113	627.7	0.9729	
THHN, THWN, THWN-2	14	2.819	0.111	6.258	0.0097
	12	3.302	0.130	8.581	0.0133
	10	4.166	0.164	13.61	0.0211
	8	5.486	0.216	23.61	0.0366
	6	6.452	0.254	32.71	0.0507
	4	8.230	0.324	53.16	0.0824
	3	8.941	0.352	62.77	0.0973
	2	9.754	0.384	74.71	0.1158
	1	11.33	0.446	100.8	0.1562
	1/0	12.34	0.486	119.7	0.1855
	2/0	13.51	0.532	143.4	0.2223
	3/0	14.83	0.584	172.8	0.2679
	4/0	16.31	0.642	208.8	0.3237
	250	18.06	0.711	256.1	0.3970
	300	19.46	0.766	297.3	0.4608
	350	20.75	0.817	338.2	0.5242
	400	21.95	0.864	378.3	0.5863
	500	24.10	0.949	456.3	0.7073
	600	26.70	1.051	559.7	0.8676
	Type: XHH, XHHW, XHHW-2				
XHHW, XHHW-2, XHH	14	3.378	0.133	8.968	0.0139
	12	3.861	0.152	11.68	0.0181
	10	4.470	0.176	15.68	0.0243
	8	5.994	0.236	28.19	0.0437
	6	6.960	0.274	38.06	0.0590
	4	8.179	0.322	52.52	0.0814
	3	8.890	0.350	62.06	0.0962
	2	9.703	0.382	73.94	0.1146
	1	11.23	0.442	98.97	0.1534
	1/0	12.24	0.482	117.7	0.1825
	2/0	13.41	0.528	141.3	0.2190
	3/0	14.73	0.58	170.5	0.2642
4/0	16.21	0.638	206.3	0.3197	
250	17.91	0.705	251.9	0.3904	
300	19.30	0.76	292.6	0.4536	
350	20.60	0.811	333.3	0.5166	
400	21.79	0.858	373.0	0.5782	
500	23.95	0.943	450.6	0.6984	
600	26.75	1.053	561.9	0.8709	

*Types RHH, RHW, and RHW-2 without outer covering.

Table 5A Compact Aluminum Building Wire Nominal Dimensions* and Areas

Size (AWG or kcmil)	Bare Conductor		Types THW and THHW				Type THHN				Type XHHW				Size (AWG or kcmil)
	Diameter		Approximate Diameter		Approximate Area		Approximate Diameter		Approximate Area		Approximate Diameter		Approximate Area		
	mm	in.	mm	in.	mm ²	in. ²	mm	in.	mm ²	in. ²	mm	in.	mm ²	in. ²	
8	3.404	0.134	6.477	0.255	32.90	0.0510	—	—	—	—	5.690	0.224	25.42	0.0394	8
6	4.293	0.169	7.366	0.290	42.58	0.0660	6.096	0.240	29.16	0.0452	6.604	0.260	34.19	0.0530	6
4	5.410	0.213	8.509	0.335	56.84	0.0881	7.747	0.305	47.10	0.0730	7.747	0.305	47.10	0.0730	4
2	6.807	0.268	9.906	0.390	77.03	0.1194	9.144	0.360	65.61	0.1017	9.144	0.360	65.61	0.1017	2
1	7.595	0.299	11.81	0.465	109.5	0.1698	10.54	0.415	87.23	0.1352	10.54	0.415	87.23	0.1352	1
1/0	8.534	0.336	12.70	0.500	126.6	0.1963	11.43	0.450	102.6	0.1590	11.43	0.450	102.6	0.1590	1/0
2/0	9.550	0.376	13.84	0.545	150.5	0.2332	12.57	0.495	124.1	0.1924	12.45	0.490	121.6	0.1885	2/0
3/0	10.74	0.423	14.99	0.590	176.3	0.2733	13.72	0.540	147.7	0.2290	13.72	0.540	147.7	0.2290	3/0
4/0	12.07	0.475	16.38	0.645	210.8	0.3267	15.11	0.595	179.4	0.2780	14.99	0.590	176.3	0.2733	4/0
250	13.21	0.520	18.42	0.725	266.3	0.4128	17.02	0.670	227.4	0.3525	16.76	0.660	220.7	0.3421	250
300	14.48	0.570	19.69	0.775	304.3	0.4717	18.29	0.720	262.6	0.4071	18.16	0.715	259.0	0.4015	300
350	15.65	0.616	20.83	0.820	340.7	0.5281	19.56	0.770	300.4	0.4656	19.30	0.760	292.6	0.4536	350
400	16.74	0.659	21.97	0.865	379.1	0.5876	20.70	0.815	336.5	0.5216	20.32	0.800	324.3	0.5026	400
500	18.69	0.736	23.88	0.940	447.7	0.6939	22.48	0.885	396.8	0.6151	22.35	0.880	392.4	0.6082	500
600	20.65	0.813	26.67	1.050	558.6	0.8659	25.02	0.985	491.6	0.7620	24.89	0.980	486.6	0.7542	600

*Dimensions are from industry sources.

Table 8 Conductor Properties

Size (AWG or kcmil)	Conductors									Direct-Current Resistance at 75°C (167°F)						
	Area			Stranding		Overall				Copper			Aluminum			
	mm ²	Circular mils	Quantity	Diameter		Diameter		Area		ohm/km	Uncoated		Coated		ohm/km	ohm/kFT
				mm	in.	mm	in.	mm ²	in. ²		ohm/kFT	ohm/kFT				
18	0.823	1620	1	—	—	1.02	0.040	0.823	0.001	25.5	7.77	26.5	8.08	42.0	12.8	
18	0.823	1620	7	0.39	0.015	1.16	0.046	1.06	0.002	26.1	7.95	27.7	8.45	42.8	13.1	
16	1.31	2580	1	—	—	1.29	0.051	1.31	0.002	16.0	4.89	16.7	5.08	26.4	8.05	
16	1.31	2580	7	0.49	0.019	1.46	0.058	1.68	0.003	16.4	4.99	17.3	5.29	26.9	8.21	
14	2.08	4110	1	—	—	1.63	0.064	2.08	0.003	10.1	3.07	10.4	3.19	16.6	5.06	
14	2.08	4110	7	0.62	0.024	1.85	0.073	2.68	0.004	10.3	3.14	10.7	3.26	16.9	5.17	
12	3.31	6530	1	—	—	2.05	0.081	3.31	0.005	6.34	1.93	6.57	2.01	10.45	3.18	
12	3.31	6530	7	0.78	0.030	2.32	0.092	4.25	0.006	6.50	1.98	6.73	2.05	10.69	3.25	
10	5.261	10380	1	—	—	2.588	0.102	5.26	0.008	3.984	1.21	4.148	1.26	6.561	2.00	
10	5.261	10380	7	0.98	0.038	2.95	0.116	6.76	0.011	4.070	1.24	4.226	1.29	6.679	2.04	
8	8.367	16510	1	—	—	3.264	0.128	8.37	0.013	2.506	0.764	2.579	0.786	4.125	1.26	
8	8.367	16510	7	1.23	0.049	3.71	0.146	10.76	0.017	2.551	0.778	2.653	0.809	4.204	1.28	
6	13.30	26240	7	1.56	0.061	4.67	0.184	17.09	0.027	1.608	0.491	1.671	0.510	2.652	0.808	
4	21.15	41740	7	1.96	0.077	5.89	0.232	27.19	0.042	1.010	0.308	1.053	0.321	1.666	0.508	
3	26.67	52620	7	2.20	0.087	6.60	0.260	34.28	0.053	0.802	0.245	0.833	0.254	1.320	0.403	
2	33.62	66360	7	2.47	0.097	7.42	0.292	43.23	0.067	0.634	0.194	0.661	0.201	1.045	0.319	
1	42.41	83690	19	1.69	0.066	8.43	0.332	55.80	0.087	0.505	0.154	0.524	0.160	0.829	0.253	
1/0	53.49	105600	19	1.89	0.074	9.45	0.372	70.41	0.109	0.399	0.122	0.415	0.127	0.660	0.201	
2/0	67.43	133100	19	2.13	0.084	10.62	0.418	88.74	0.137	0.3170	0.0967	0.329	0.101	0.523	0.159	
3/0	85.01	167800	19	2.39	0.094	11.94	0.470	111.9	0.173	0.2512	0.0766	0.2610	0.0797	0.413	0.126	
4/0	107.2	211600	19	2.68	0.106	13.41	0.528	141.1	0.219	0.1996	0.0608	0.2050	0.0626	0.328	0.100	
250	127	—	37	2.09	0.082	14.61	0.575	168	0.260	0.1687	0.0515	0.1753	0.0535	0.2778	0.0847	
300	152	—	37	2.29	0.090	16.00	0.630	201	0.312	0.1409	0.0429	0.1463	0.0446	0.2318	0.0707	
350	177	—	37	2.47	0.097	17.30	0.681	235	0.364	0.1205	0.0367	0.1252	0.0382	0.1984	0.0605	
400	203	—	37	2.64	0.104	18.49	0.728	268	0.416	0.1053	0.0321	0.1084	0.0331	0.1737	0.0529	
500	253	—	37	2.95	0.116	20.65	0.813	336	0.519	0.0845	0.0258	0.0869	0.0265	0.1391	0.0424	
600	304	—	61	2.52	0.099	22.68	0.893	404	0.626	0.0704	0.0214	0.0732	0.0223	0.1159	0.0353	

Notes:

1. These resistance values are valid **only** for the parameters as given. Using conductors having coated strands, different stranding type, and, especially, other temperatures changes the resistance.
2. Formula for temperature change: $R_2 = R_1 [1 + \alpha (T_2 - 75)]$ where $\alpha_{cu} = 0.00323$, $\alpha_{AL} = 0.00330$ at 75°C.
3. Conductors with compact and compressed stranding have about 9 percent and 3 percent, respectively, smaller bare conductor diameters than those shown. See Table 5A for actual compact cable dimensions.
4. The IACS conductivities used: bare copper = 100%, aluminum = 61%.
5. Class B stranding is listed as well as solid for some sizes. Its overall diameter and area is that of its circumscribing circle.

Annex C Conduit and Tubing Fill Tables for Conductors and Fixture Wires of the Same Size

This annex is not a part of the requirements of this NFPA document but is included for informational purposes only.

Table	
C.1 — Electrical Metallic Tubing (EMT)	
C.1(A)* — Electrical Metallic Tubing (EMT)	
C.2 — Electrical Nonmetallic Tubing (ENT)	
C.2(A)* — Electrical Nonmetallic Tubing (ENT)	
C.3 — Flexible Metal Conduit (FMC)	
C.3(A)* — Flexible Metal Conduit (FMC)	
C.4 — Intermediate Metal Conduit (IMC)	
C.4(A)* — Intermediate Metal Conduit (IMC)	
C.5 — Liquidtight Flexible Nonmetallic Conduit (Type LFNC-B)	
C.5(A)* — Liquidtight Flexible Nonmetallic Conduit (Type LFNC-B)	
C.6 — Liquidtight Flexible Nonmetallic Conduit (Type LFNC-A)	
C.6(A)* — Liquidtight Flexible Nonmetallic Conduit (Type LFNC-A)	
C.7 — Liquidtight Flexible Metal Conduit (LFMC)	
C.7(A)* — Liquidtight Flexible Metal Conduit (LFMC)	
C.8 — Rigid Metal Conduit (RMC)	
C.8(A)* — Rigid Metal Conduit (RMC)	
C.9 — Rigid PVC Conduit, Schedule 80	
C.9(A)* — Rigid PVC Conduit, Schedule 80	
C.10 — Rigid PVC Conduit, Schedule 40 and HDPE Conduit	
C.10(A)* — Rigid PVC Conduit, Schedule 40 and HDPE Conduit	

*Where this table is used in conjunction with Tables C.1 through C.10, the conductors installed must be of the compact type.

Table C.1 Maximum Number of Conductors in Electrical Metallic Tubing (EMT) (Based on Table I, Chapter 9)

		CONDUCTORS									
		Metric Designator (Trade Size)									
Type	Conductor Size (AWG kcmil)	16 (½)	21 (¾)	27 (1)	35 (1¼)	41 (1½)	53 (2)	63 (2½)	78 (3)	91 (3½)	103 (4)
RHH, RHW, RHW-2	14	4	7	11	20	27	46	80	120	157	201
	12	3	6	9	17	23	38	66	100	131	167
	10	2	5	8	13	18	30	53	81	105	135
	8	1	2	4	7	9	16	28	42	55	70
	6	1	1	3	5	8	13	22	34	44	56
	4	1	1	2	4	6	10	17	26	34	44
	3	1	1	1	4	5	9	15	23	30	38
	2	1	1	1	3	4	7	13	20	26	33
	1	0	1	1	1	3	5	9	13	17	22
	1/0	0	1	1	1	2	4	7	11	15	19
2/0	0	1	1	1	2	4	6	10	13	17	
3/0	0	0	1	1	1	3	5	8	11	14	
4/0	0	0	1	1	1	3	5	7	9	12	
250	0	0	0	1	1	1	3	5	7	9	
300	0	0	0	1	1	1	3	5	6	8	
350	0	0	0	1	1	1	3	4	6	7	
400	0	0	0	1	1	1	2	4	5	7	
500	0	0	0	0	1	1	2	3	4	6	
600	0	0	0	0	1	1	1	3	4	5	
TW	14	8	15	25	43	58	96	168	254	332	424
	12	6	11	19	33	45	74	129	195	255	326
	10	5	8	14	24	33	55	96	145	190	243
	8	2	5	8	13	18	30	53	81	105	135
	6	1	2	4	7	9	16	28	42	55	70
RHH*, RHW*, RHW-2*, THHW, THW, THW-2	14	6	10	16	28	39	64	112	169	221	282

Table C.1 Continued

		CONDUCTORS									
		Metric Designator (Trade Size)									
Type	Conductor Size (AWG kcmil)	16 (½)	21 (¾)	27 (1)	35 (1¼)	41 (1½)	53 (2)	63 (2½)	78 (3)	91 (3½)	103 (4)
RHH*, RHW*, RHW-2*, THHW, THW	12	4	8	13	23	31	51	90	136	177	227
	10	3	6	10	18	24	40	70	106	138	177
RHH*, RHW*, RHW-2*, THHW, THW, THW-2	8	1	4	6	10	14	24	42	63	83	106
	6	1	3	4	8	11	18	32	48	63	81
RHH*, RHW*, RHW-2*, TW, THW, THHW, THW-2	4	1	1	3	6	8	13	24	36	47	60
	3	1	1	3	5	7	12	20	31	40	52
	2	1	1	2	4	6	10	17	26	34	44
	1	1	1	1	3	4	7	12	18	24	31
	1/0	0	1	1	2	3	6	10	16	20	26
	2/0	0	1	1	1	3	5	9	13	17	22
	3/0	0	1	1	1	2	4	7	11	15	19
	4/0	0	0	1	1	1	3	6	9	12	16
	250	0	0	1	1	1	3	5	7	10	13
	300	0	0	1	1	1	2	4	6	8	11
350	0	0	0	1	1	1	4	6	7	10	
400	0	0	0	1	1	1	3	5	7	9	
500	0	0	0	1	1	1	3	4	6	7	
600	0	0	0	1	1	1	2	3	4	6	
THHN, THWN, THWN-2	14	12	22	35	61	84	138	241	364	476	608
	12	9	16	26	45	61	101	176	266	347	443
	10	5	10	16	28	38	63	111	167	219	279
	8	3	6	9	16	22	36	64	96	126	161
	6	2	4	7	12	16	26	46	69	91	116
RHH, RHW, RHW-2	4	1	2	4	7	10	16	28	43	56	71
	3	1	1	3	6	8	13	24	36	47	60
	2	1	1	3	5	7	11	20	30	40	51
	1	1	1	1	4	5	8	15	22	29	37
	1/0	1	1	1	3	4	7	12	19	25	32
	2/0	0	1	1	2	3	6	10	16	20	26
	3/0	0	1	1	1	3	5	8	13	17	22
	4/0	0	1	1	1	2	4	7	11	14	18
	250	0	0	1	1	1	3	6	9	11	15
	300	0	0	1	1	1	3	5	7	10	13
350	0	0	1	1	1	2	4	6	9	11	
400	0	0	0	1	1	1	4	6	8	10	
500	0	0	0	1	1	1	3	5	6	8	
600	0	0	0	1	1	1	2	4	5	7	
XHH, XHHW, XHHW-2	14	8	15	25	43	58	96	168	254	332	424
	12	6	11	19	33	45	74	129	195	255	326
	10	5	8	14	24	33	55	96	145	190	243
	8	2	5	8	13	18	30	53	81	105	135
	6	1	3	6	10	14	22	39	60	78	100
RHH, RHW, RHW-2	4	1	2	4	7	10	16	28	43	56	72
	3	1	1	3	6	8	14	24	36	48	61
	2	1	1	3	5	7	11	20	31	40	51
	1	1	1	1	4	5	8	15	23	30	38
	1/0	1	1	1	3	4	7	13	19	25	32
	2/0	0	1	1	2	3	6	10	16	21	27
	3/0	0	1	1	1	3	5	9	13	17	22
	4/0	0	1	1	1	2	4	7	11	14	18
	250	0	0	1	1	1	3	6	9	12	15
	300	0	0	1	1	1	3	5	8	10	13
350	0	0	1	1	1	2	4	7	9	11	
400	0	0	0	1	1	1	4	6	8	10	
500	0	0	0	1	1	1	3	5	6	8	
600	0	0	0	1	1	1	2	4	5	6	

Notes:

1. This table is for concentric stranded conductors only. For compact stranded conductors, Table C.1(A) should be used.

2. Two-hour fire-rated RHH cable has ceramic insulation which has much larger diameters than other RHH wires.

Consult manufacturer's conduit fill tables.

*Types RHH, RHW, and RHW-2 without outer covering.

Table C.1(A) Maximum Number of Compact Conductors in Electrical Metallic Tubing (EMT) (Based on Table 1, Chapter 9)

COMPACT CONDUCTORS											
Type	Conductor Size (AWG/kcmil)	Metric Designator (Trade Size)									
		16 (1/2)	21 (3/4)	27 (1)	35 (1 1/4)	41 (1 1/2)	53 (2)	63 (2 1/2)	78 (3)	91 (3 1/2)	103 (4)
THW, THW-2, THHW	8	2	4	6	11	16	26	46	69	90	115
	6	1	3	5	9	12	20	35	53	70	89
	4	1	2	4	6	9	15	26	40	52	67
	2	1	1	3	5	7	11	19	29	38	49
	1	1	1	1	3	4	8	13	21	27	34
	1/0	1	1	1	3	4	7	12	18	23	30
	2/0	0	1	1	2	3	5	10	15	20	25
	3/0	0	1	1	1	3	5	8	13	17	21
	4/0	0	1	1	1	2	4	7	11	14	18
	250	0	0	1	1	1	3	5	8	11	14
300	0	0	1	1	1	3	5	7	9	12	
350	0	0	1	1	1	2	4	6	8	11	
400	0	0	0	1	1	1	4	6	8	10	
500	0	0	0	1	1	1	3	5	6	8	
600	0	0	0	1	1	1	2	4	5	7	
THHN, THWN, THWN-2	8	—	—	—	—	—	—	—	—	—	—
	6	2	4	7	13	18	29	52	78	102	130
	4	1	3	4	8	11	18	32	48	63	81
	2	1	1	3	6	8	13	23	34	45	58
	1	1	1	2	4	6	10	17	26	34	43
	1/0	1	1	1	3	5	8	14	22	29	37
	2/0	1	1	1	3	4	7	12	18	24	30
	3/0	0	1	1	2	3	6	10	15	20	25
	4/0	0	1	1	1	3	5	8	12	16	21
	250	0	1	1	1	1	4	6	10	13	16
300	0	0	1	1	1	3	5	8	11	14	
350	0	0	1	1	1	3	5	7	10	12	
400	0	0	1	1	1	2	4	6	9	11	
500	0	0	0	1	1	1	4	5	7	9	
600	0	0	0	1	1	1	3	4	6	7	
XHHW, XHHW-2	8	3	5	8	15	20	34	59	90	117	149
	6	1	4	6	11	15	25	44	66	87	111
	4	1	3	4	8	11	18	32	48	63	81
	2	1	1	3	6	8	13	23	34	45	58
	1	1	1	2	4	6	10	17	26	34	43
	1/0	1	1	1	3	5	8	14	22	29	37
	2/0	1	1	1	3	4	7	12	18	24	31
	3/0	0	1	1	2	3	6	10	15	20	25
	4/0	0	1	1	1	3	5	8	13	17	21
	250	0	1	1	1	2	4	7	10	13	17
300	0	0	1	1	1	3	6	9	11	14	
350	0	0	1	1	1	3	5	8	10	13	
400	0	0	1	1	1	2	4	7	9	11	
500	0	0	0	1	1	1	4	6	7	9	
600	0	0	0	1	1	1	3	4	6	8	

Definition: Compact stranding is the result of a manufacturing process where the standard conductor is compressed to the extent that the interstices (voids between strand wires) are virtually eliminated.

Table C.2 Maximum Number of Conductors in Electrical Nonmetallic Tubing (ENT) (Based on Table 1, Chapter 9)

CONDUCTORS							
Type	Conductor Size (AWG/kcmil)	Metric Designator (Trade Size)					
		16 (1/2)	21 (3/4)	27 (1)	35 (1 1/4)	41 (1 1/2)	53 (2)
RHH, RHW, RHW-2	14	3	6	10	19	26	43
	12	2	5	9	16	22	36
	10	1	4	7	13	17	29
	8	1	1	3	6	9	15
	6	1	1	3	5	7	12
	4	1	1	2	4	6	9
	3	1	1	1	3	5	8
	2	0	1	1	3	4	7
	1	0	1	1	1	3	5
	1/0	0	0	1	1	2	4
2/0	0	0	1	1	1	3	
3/0	0	0	1	1	1	3	
4/0	0	0	1	1	1	2	
250	0	0	0	1	1	1	
300	0	0	0	1	1	1	
350	0	0	0	1	1	1	
400	0	0	0	1	1	1	
500	0	0	0	1	1	1	
600	0	0	0	0	1	1	
TW	14	7	13	22	40	55	92
	12	5	10	17	31	42	71
	10	4	7	13	23	32	52
	8	1	4	7	13	17	29
	6	1	3	5	10	14	23
	4	1	2	4	7	10	17
	3	1	1	3	5	8	13
	2	1	1	2	4	6	9
	1	0	1	1	3	4	6
	1/0	0	1	1	2	3	5
2/0	0	1	1	1	3	5	
3/0	0	0	1	1	2	4	
4/0	0	0	1	1	1	3	
250	0	0	0	1	1	2	
300	0	0	0	1	1	2	
350	0	0	0	1	1	1	
400	0	0	0	1	1	1	
500	0	0	0	1	1	1	
600	0	0	0	0	1	1	
THHN, THWN, THWN-2	14	10	18	32	58	80	132
	12	7	13	23	42	58	96
	10	4	8	15	26	36	60
	8	2	5	8	15	21	35
	6	1	3	6	11	15	25
	4	1	1	4	7	9	15
	3	1	1	3	5	8	13
	2	1	1	2	5	6	11
	1	1	1	1	3	5	8
	1/0	0	1	1	3	4	7
2/0	0	1	1	2	3	5	
3/0	0	1	1	1	3	4	
4/0	0	0	1	1	2	4	
250	0	0	1	1	1	3	
300	0	0	1	1	1	2	
350	0	0	0	1	1	2	
400	0	0	0	1	1	1	
500	0	0	0	1	1	1	
600	0	0	0	1	1	1	

Table C.2 Continued

CONDUCTORS							
Type	Conductor Size (AWG/kcmil)	Metric Designator (Trade Size)					
		16 (1/2)	21 (3/4)	27 (1)	35 (1 1/4)	41 (1 1/2)	53 (2)
XHH, XHHW, XHHW-2	14	7	13	22	40	55	92
	12	5	10	17	31	42	71
	10	4	7	13	23	32	52
	8	1	4	7	13	17	29
	6	1	3	5	9	13	21
	4	1	1	4	7	9	15
	3	1	1	3	6	8	13
	2	1	1	2	5	6	11
	1	1	1	1	3	5	8
	1/0	0	1	1	3	4	7
	2/0	0	1	1	2	3	6
	3/0	0	1	1	1	3	5
	4/0	0	0	1	1	2	4
	250	0	0	1	1	1	3
	300	0	0	1	1	1	3
	350	0	0	1	1	1	2
	400	0	0	0	1	1	1
500	0	0	0	1	1	1	
600	0	0	0	1	1	1	

Notes:
 1. This table is for concentric stranded conductors only. For compact stranded conductors, Table C.2(A) should be used.
 2. Two-hour fire-rated RHH cable has ceramifiable insulation which has much larger diameters than other RHH wires.
 Consult manufacturer's conduit fill tables.
 *Types RHH, RHW, and RHW-2 without outer covering.

Table C.2(A) Maximum Number of Compact Conductors in Electrical Nonmetallic Tubing (ENT) (Based on Table 1, Chapter 9)

COMPACT CONDUCTORS								
Type	Conductor Size (AWG/kcmil)	Metric Designator (Trade Size)						
		16 (1/2)	21 (3/4)	27 (1)	35 (1 1/4)	41 (1 1/2)	53 (2)	
THW, THW-2, THHW	8	1	3	6	11	15	25	
	6	1	2	4	8	11	19	
	4	1	1	3	6	8	14	
	2	1	1	2	4	6	10	
	1	0	1	1	3	4	7	
	1/0	0	1	1	3	4	6	
	2/0	0	1	1	2	3	5	
	3/0	0	1	1	1	3	4	
	4/0	0	0	1	1	2	4	
	250	0	0	1	1	1	3	
	300	0	0	1	1	1	2	
	350	0	0	0	1	1	2	
	400	0	0	0	1	1	1	
	500	0	0	0	1	1	1	
	600	0	0	0	1	1	1	
	THHN, THWN, THWN-2	8	—	—	—	—	—	—
		6	1	4	7	12	17	28
4		1	2	4	7	10	17	
2		1	1	3	5	7	12	
1		1	1	2	4	5	9	
1/0		1	1	1	3	5	8	
2/0		0	1	1	3	4	6	
3/0		0	1	1	2	3	5	
4/0		0	1	1	1	2	4	
250		0	0	1	1	1	3	
300		0	0	1	1	1	3	
350		0	0	1	1	1	2	
400		0	0	0	1	1	2	
500		0	0	0	1	1	1	
600		0	0	0	1	1	1	
XHHW, XHHW-2		8	2	4	8	14	19	32
		6	1	3	6	10	14	24
	4	1	2	4	7	10	17	
	2	1	1	3	5	7	12	
	1	1	1	2	4	5	9	
	1/0	1	1	1	3	5	8	
	2/0	0	1	1	3	4	7	
	3/0	0	1	1	2	3	5	
	4/0	0	1	1	1	3	4	
	250	0	0	1	1	1	3	
	300	0	0	1	1	1	3	
	350	0	0	1	1	1	3	
	400	0	0	1	1	1	2	
	500	0	0	0	1	1	1	
	600	0	0	0	1	1	1	

Definition: Compact stranding is the result of a manufacturing process where the standard conductor is compressed to the extent that the interstices (voids between strand wires) are virtually eliminated.

Table C.3 Maximum Number of Conductors in Flexible Metal Conduit (FMC) (Based on Table 1, Chapter 9)

CONDUCTORS											
Type	Conductor Size (AWG/kcmil)	Metric Designator (Trade Size)									
		16 (1/2)	21 (3/4)	27 (1)	35 (1 1/4)	41 (1 1/2)	53 (2)	63 (2 1/2)	78 (3)	91 (3 1/2)	103 (4)
RHH, RHW, RHW-2	14	4	7	11	17	25	44	67	96	131	171
	12	3	6	9	14	21	37	55	80	109	142
	10	3	5	7	11	17	30	45	64	88	115
	8	1	2	4	6	9	15	23	34	46	60
	6	1	1	3	5	7	12	19	27	37	48
	4	1	1	2	4	5	10	14	21	29	37
	3	1	1	1	3	5	8	13	18	25	33
	2	1	1	1	3	4	7	11	16	22	28
	1	0	1	1	1	2	5	7	10	14	19
	1/0	0	1	1	1	2	4	6	9	12	16
	2/0	0	1	1	1	3	5	8	11	14	14
	3/0	0	0	1	1	3	5	7	9	12	12
	4/0	0	0	1	1	2	4	6	8	10	10
	250	0	0	0	1	1	3	4	6	8	8
	300	0	0	0	1	1	2	4	5	7	7
	350	0	0	0	1	1	2	3	5	6	6
	400	0	0	0	0	1	1	3	4	6	6
500	0	0	0	0	1	1	3	4	5	5	
600	0	0	0	0	1	1	2	3	4	4	
TW	14	9	15	23	36	53	94	141	203	277	361
	12	7	11	18	28	41	72	108	156	212	277
	10	5	8	13	21	30	54	81	116	158	207
	8	3	5	7	11	17	30	45	64	88	115
RHH*, RHW*, RHW-2*, THHW, THW, THW-2	14	6	10	15	24	35	62	94	135	184	240
	12	5	8	12	19	28	50	75	108	148	193
	10	4	6	10	15	22	39	59	85	115	151
	8	1	4	6	9	13	23	35	51	69	90
	6	1	3	4	7	10	18	27	39	53	69
	4	1	1	3	5	7	13	20	29	39	51
	3	1	1	3	4	6	11	17	25	34	44
	2	1	1	2	4	5	10	14	21	29	37
	1	1	1	1	2	4	7	10	15	20	26
	1/0	0	1	1	1	3	6	9	12	17	22
	2/0	0	1	1	1	3	5	7	10	14	19
	3/0	0	1	1	1	2	4	6	9	12	16
	4/0	0	0	1	1	3	5	7	10	13	13
	250	0	0	1	1	3	4	6	8	11	11
	300	0	0	1	1	2	3	5	7	9	9
	350	0	0	0	1	1	3	4	6	8	8
	400	0	0	0	1	1	3	4	6	7	7
500	0	0	0	1	1	2	3	5	6	6	
600	0	0	0	0	1	1	3	4	5	5	
THHN, THWN, THWN-2	14	13	22	33	52	76	134	202	291	396	518
	12	9	16	24	38	56	98	147	212	289	378
	10	6	10	15	24	35	62	93	134	182	238
	8	3	6	9	14	20	35	53	77	105	137
	6	2	4	6	10	14	25	38	55	76	99
	4	1	2	4	6	9	16	24	34	46	61
	3	1	1	3	5	7	13	20	29	39	51
	2	1	1	3	4	6	11	17	24	33	43
	1	1	1	1	3	4	8	12	18	24	32
	1/0	1	1	1	2	4	7	10	15	20	27
	2/0	0	1	1	1	3	6	9	12	17	22
	3/0	0	1	1	1	2	5	7	10	14	18
	4/0	0	1	1	1	1	4	6	8	12	15
	250	0	0	1	1	3	5	7	9	12	12
	300	0	0	1	1	3	4	6	8	11	11
	350	0	0	1	1	2	3	5	7	9	9
	400	0	0	0	1	1	3	5	6	8	8
500	0	0	0	1	1	2	4	5	7	7	
600	0	0	0	0	1	1	3	4	5	5	

Table C.3 Continued

CONDUCTORS											
Type	Conductor Size (AWG/kcmil)	Metric Designator (Trade Size)									
		16 (1/2)	21 (3/4)	27 (1)	35 (1 1/4)	41 (1 1/2)	53 (2)	63 (2 1/2)	78 (3)	91 (3 1/2)	103 (4)
XHH, XHHW, XHHW-2	14	9	15	23	36	53	94	141	203	277	361
	12	7	11	18	28	41	72	108	156	212	277
	10	5	8	13	21	30	54	81	116	158	207
	8	3	5	7	11	17	30	45	64	88	115
	6	1	3	5	8	12	22	33	48	65	85
	4	1	2	4	6	9	16	24	34	47	61
	3	1	1	3	5	7	13	20	29	40	52
	2	1	1	3	4	6	11	17	24	33	44
	1	1	1	1	3	5	8	13	18	25	32
	1/0	1	1	1	2	4	7	10	15	21	27
2/0	0	1	1	2	3	6	9	13	17	23	
3/0	0	1	1	1	3	5	7	10	14	19	
4/0	0	1	1	1	2	4	6	9	12	15	
250	0	0	1	1	1	3	5	7	10	13	
300	0	0	1	1	1	3	4	6	8	11	
350	0	0	1	1	1	2	4	5	7	9	
400	0	0	0	1	1	1	3	5	6	8	
500	0	0	0	1	1	1	3	4	5	7	
600	0	0	0	0	1	1	1	3	4	5	

Notes:
 1. This table is for concentric stranded conductors only. For compact stranded conductors, Table C.3(A) should be used.
 2. Two-hour fire-rated RHH cable has ceramic insulation which has much larger diameters than other RHH wires.
 Consult manufacturer's conduit fill tables.
 *Types RHH, RHW, and RHW-2 without outer covering.

Table C.3(A) Maximum Number of Compact Conductors in Flexible Metal Conduit (FMC) (Based on Table 1, Chapter 9)

COMPACT CONDUCTORS											
Type	Conductor Size (AWG/kcmil)	Metric Designator (Trade Size)									
		16 (1/2)	21 (3/4)	27 (1)	35 (1 1/4)	41 (1 1/2)	53 (2)	63 (2 1/2)	78 (3)	91 (3 1/2)	103 (4)
THW, THHW, THW-2	8	2	4	6	10	14	25	38	55	75	98
	6	1	3	5	7	11	20	29	43	58	76
	4	1	2	3	5	8	15	22	32	43	57
	2	1	1	2	4	6	11	16	23	32	42
	1	1	1	1	3	4	7	11	16	22	29
	1/0	1	1	1	2	3	6	10	14	19	25
	2/0	0	1	1	1	3	5	8	12	16	21
	3/0	0	1	1	1	2	4	7	10	14	18
	4/0	0	1	1	1	1	4	6	8	11	15
	250	0	0	1	1	1	3	4	7	9	12
300	0	0	1	1	1	2	4	6	8	10	
350	0	0	1	1	1	2	3	5	7	9	
400	0	0	0	1	1	1	3	5	6	8	
500	0	0	0	1	1	1	3	4	5	7	
600	0	0	0	0	1	1	1	3	4	6	
THHN, THWN, THWN-2	8	—	—	—	—	—	—	—	—	—	—
	6	3	4	7	11	16	29	43	62	85	111
	4	1	3	4	7	10	18	27	38	52	69
	2	1	1	3	5	7	13	19	28	38	49
	1	1	1	2	3	5	9	14	21	28	37
	1/0	1	1	1	3	4	8	12	17	24	31
	2/0	1	1	1	2	4	6	10	14	20	26
	3/0	0	1	1	1	3	5	8	12	17	22
	4/0	0	1	1	1	2	4	7	10	14	18
	250	0	1	1	1	1	3	5	8	11	14
300	0	0	1	1	1	3	5	7	9	12	
350	0	0	1	1	1	3	4	6	8	10	
400	0	0	1	1	1	2	3	5	7	9	
500	0	0	0	1	1	1	3	4	6	8	
600	0	0	0	1	1	1	2	3	5	6	

Table C.3(A) Continued

COMPACT CONDUCTORS											
Type	Conductor Size (AWG/kcmil)	Metric Designator (Trade Size)									
		16 (1/2)	21 (3/4)	27 (1)	35 (1 1/4)	41 (1 1/2)	53 (2)	63 (2 1/2)	78 (3)	91 (3 1/2)	103 (4)
XHHW, XHHW-2	8	3	5	8	13	19	33	50	71	97	127
	6	2	4	6	9	14	24	37	53	72	95
	4	1	3	4	7	10	18	27	38	52	69
	2	1	1	3	5	7	13	19	28	38	49
	1	1	1	2	3	5	9	14	21	28	37
	1/0	1	1	1	3	4	8	12	17	24	31
	2/0	1	1	1	2	4	7	10	15	20	26
	3/0	0	1	1	1	3	5	8	12	17	22
	4/0	0	1	1	1	2	4	7	10	14	18
	250	0	1	1	1	1	4	5	8	11	14
300	0	0	1	1	1	3	5	7	9	12	
350	0	0	1	1	1	3	4	6	8	11	
400	0	0	1	1	1	2	4	5	7	10	
500	0	0	0	1	1	1	3	4	6	8	
600	0	0	0	1	1	1	2	3	5	6	

Definition: Compact stranding is the result of a manufacturing process where the standard conductor is compressed to the extent that the interstices (voids between strand wires) are virtually eliminated.

Table C.4 Maximum Number of Conductors in Intermediate Metal Conduit (IMC) (Based on Table 1, Chapter 9)

CONDUCTORS											
Type	Conductor Size (AWG/kcmil)	Metric Designator (Trade Size)									
		16 (1/2)	21 (3/4)	27 (1)	35 (1 1/4)	41 (1 1/2)	53 (2)	63 (2 1/2)	78 (3)	91 (3 1/2)	103 (4)
RHH, RHW, RHW-2	14	4	8	13	22	30	49	70	108	144	186
	12	4	6	11	18	25	41	58	89	120	154
	10	3	5	8	15	20	33	47	72	97	124
	8	1	3	4	8	10	17	24	38	50	65
	6	1	1	3	6	8	14	19	30	40	52
	4	1	1	3	5	6	11	15	23	31	41
	3	1	1	2	4	6	9	13	21	28	36
	2	1	1	1	3	5	8	11	18	24	31
	1	0	1	1	2	3	5	7	12	16	20
	1/0	0	1	1	1	3	4	6	10	14	18
2/0	0	1	1	1	2	4	6	9	12	15	
3/0	0	0	1	1	1	3	5	7	10	13	
4/0	0	0	1	1	1	3	4	6	9	11	
250	0	0	1	1	1	1	3	5	6	8	
300	0	0	0	1	1	1	3	4	6	7	
350	0	0	0	1	1	1	2	4	5	7	
400	0	0	0	1	1	1	2	3	5	6	
500	0	0	0	1	1	1	1	3	4	5	
600	0	0	0	0	1	1	1	2	3	4	
TW	14	10	17	27	47	64	104	147	228	304	392
	12	7	13	21	36	49	80	113	175	234	301
	10	5	9	15	27	36	59	84	130	174	224
	8	3	5	8	15	20	33	47	72	97	124
RHH*, RHW*, RHW-2*, THHW, THW, THW-2	14	6	11	18	31	42	69	98	151	202	261
	12	5	9	14	25	34	56	79	122	163	209
	10	4	7	11	19	26	43	61	95	127	163
	8	2	4	7	12	16	26	37	57	76	98
RHH*, RHW*, RHW-2*, THHW, THW, THW-2	14	6	11	18	31	42	69	98	151	202	261
	12	5	9	14	25	34	56	79	122	163	209
	10	4	7	11	19	26	43	61	95	127	163
	8	2	4	7	12	16	26	37	57	76	98

Table C.4 Continued

		CONDUCTORS									
		Metric Designator (Trade Size)									
Type	Conductor Size (AWG/kcmil)	16 (1/2)	21 (3/4)	27 (1)	35 (1 1/4)	41 (1 1/2)	53 (2)	63 (2 1/2)	78 (3)	91 (3 1/2)	103 (4)
RHH*, RHW*, RHW-2*, TW, THHW, THW, THW-2	6	1	3	5	9	12	20	28	43	58	75
	4	1	2	4	6	9	15	21	32	43	56
	3	1	1	3	6	8	13	18	28	37	48
	2	1	1	3	5	6	11	15	23	31	41
	1	1	1	1	3	4	7	11	16	22	28
	1/0	1	1	1	3	4	6	9	14	19	24
	2/0	0	1	1	2	3	5	8	12	16	20
	3/0	0	1	1	1	3	4	6	10	13	17
	4/0	0	1	1	1	2	4	5	8	11	14
	250	0	0	1	1	1	3	4	7	9	12
	300	0	0	1	1	1	2	4	6	8	10
	350	0	0	1	1	1	2	3	5	7	9
	400	0	0	0	1	1	1	3	4	6	8
	500	0	0	0	1	1	1	2	4	5	7
	600	0	0	0	1	1	1	3	4	5	6
THHN, THWN, THWN-2	14	14	24	39	68	91	149	211	326	436	562
	12	10	17	29	49	67	109	154	238	318	410
	10	6	11	18	31	42	68	97	150	200	258
	8	3	6	10	18	24	39	56	86	115	149
	6	2	4	7	13	17	28	40	62	83	107
	4	1	3	4	8	10	17	25	38	51	66
	3	1	2	4	6	9	15	21	32	43	56
	2	1	1	3	5	7	12	17	27	36	47
	1	1	1	2	4	5	9	13	20	27	35
	1/0	1	1	1	3	4	8	11	17	23	29
	2/0	1	1	1	3	4	6	9	14	19	24
	3/0	0	1	1	2	3	5	7	12	16	20
	4/0	0	1	1	1	2	4	6	9	13	17
	250	0	0	1	1	1	3	5	8	10	13
	300	0	0	1	1	1	3	4	7	9	12
	350	0	0	1	1	1	2	4	6	8	10
	400	0	0	1	1	1	2	3	5	7	9
	500	0	0	0	1	1	1	3	4	6	7
	600	0	0	0	1	1	1	2	3	5	6
XHH, XHHW, XHHW-2	14	10	17	27	47	64	104	147	228	304	392
	12	7	13	21	36	49	80	113	175	234	301
	10	5	9	15	27	36	59	84	130	174	224
	8	3	5	8	15	20	33	47	72	97	124
	6	1	4	6	11	15	24	35	53	71	92
	4	1	3	4	8	11	18	25	39	52	67
	3	1	2	4	7	9	15	21	33	44	56
	2	1	1	3	5	7	12	18	27	37	47
	1	1	1	2	4	5	9	13	20	27	35
	1/0	1	1	1	3	5	8	11	17	23	30
	2/0	1	1	1	3	4	6	9	14	19	25
	3/0	0	1	1	2	3	5	7	12	16	20
	4/0	0	1	1	1	2	4	6	10	13	17
	250	0	0	1	1	1	3	5	8	11	14
	300	0	0	1	1	1	3	4	7	9	12
	350	0	0	1	1	1	3	4	6	8	10
	400	0	0	1	1	1	2	3	5	7	9
	500	0	0	0	1	1	1	3	4	6	8
	600	0	0	0	1	1	1	2	3	5	6

Notes:
 1. This table is for concentric stranded conductors only. For compact stranded conductors, Table C.4(A) should be used.
 2. Two-hour fire-rated RHH cable has ceramic insulation which has much larger diameters than other RHH wires.
 Consult manufacturer's conduit fill tables.
 *Types RHH, RHW, and RHW-2 without outer covering.

Table C.4(A) Maximum Number of Compact Conductors in Intermediate Metal Conduit (IMC) (Based on Table 1, Chapter 9)

		COMPACT CONDUCTORS									
		Metric Designator (Trade Size)									
Type	Conductor Size (AWG/kcmil)	16 (1/2)	21 (3/4)	27 (1)	35 (1 1/4)	41 (1 1/2)	53 (2)	63 (2 1/2)	78 (3)	91 (3 1/2)	103 (4)
THW, THW-2, THHW	8	2	4	7	13	17	28	40	62	83	107
	6	1	3	6	10	13	22	31	48	64	82
	4	1	2	4	7	10	16	23	36	48	62
	2	1	1	3	5	7	12	17	26	35	45
	1	1	1	1	4	5	8	12	18	25	32
	1/0	1	1	1	3	4	7	10	16	21	27
	2/0	0	1	1	3	4	6	9	13	18	23
	3/0	0	1	1	2	3	5	7	11	15	20
	4/0	0	1	1	1	2	4	6	9	13	16
	250	0	0	1	1	1	3	5	7	10	13
	300	0	0	1	1	1	3	4	6	9	11
	350	0	0	1	1	1	2	4	6	8	10
	400	0	0	1	1	1	2	3	5	7	9
	500	0	0	0	1	1	1	3	4	6	8
	600	0	0	0	1	1	1	2	3	5	6
THHN, THWN, THWN-2	8	—	—	—	—	—	—	—	—	—	—
	6	3	5	8	14	19	32	45	70	93	120
	4	1	3	5	9	12	20	28	43	58	74
	2	1	1	3	6	8	14	20	31	41	53
	1	1	1	3	5	6	10	15	23	31	40
	1/0	1	1	2	4	5	9	13	20	26	34
	2/0	1	1	1	3	4	7	10	16	22	28
	3/0	0	1	1	3	4	6	9	14	18	24
	4/0	0	1	1	2	3	5	7	11	15	19
	250	0	1	1	1	2	4	6	9	12	15
	300	0	0	1	1	1	3	5	7	10	13
	350	0	0	1	1	1	3	4	7	9	11
	400	0	0	1	1	1	2	4	6	8	10
	500	0	0	1	1	1	2	3	5	7	9
	600	0	0	0	1	1	1	2	4	5	7
XHHW, XHHW-2	8	3	6	9	16	22	37	52	80	107	138
	6	2	4	7	12	16	27	38	59	80	103
	4	1	3	5	9	12	20	28	43	58	74
	2	1	1	3	6	8	14	20	31	41	53
	1	1	1	3	5	6	10	15	23	31	40
	1/0	1	1	2	4	5	9	13	20	26	34
	2/0	1	1	1	3	4	7	11	17	22	29
	3/0	0	1	1	3	4	6	9	14	18	24
	4/0	0	1	1	2	3	5	7	11	15	20
	250	0	1	1	1	2	4	6	9	12	16
	300	0	0	1	1	1	3	5	8	10	13
	350	0	0	1	1	1	3	4	7	9	12
	400	0	0	1	1	1	3	4	6	8	11
	500	0	0	1	1	1	2	3	5	7	9
	600	0	0	0	1	1	1	2	4	5	7

Definition: Compact stranding is the result of a manufacturing process where the standard conductor is compressed to the extent that interstices (voids between strand wires) are virtually eliminated.

Table C.5 Maximum Number of Conductors in Liquidtight Flexible Nonmetallic Conduit (Type LFNC-B*) (Based on Table 1, Chapter 9)

CONDUCTORS								
Type	Conductor Size (AWG/kcmil)	Metric Designator (Trade Size)						
		12 (3/8)	16 (1/2)	21 (3/4)	27 (1)	35 (1 1/4)	41 (1 1/2)	53 (2)
RHH, RHW, RHW-2	14	2	4	7	12	21	27	44
	12	1	3	6	10	17	22	36
	10	1	3	5	8	14	18	29
	8	1	1	2	4	7	9	15
	6	1	1	1	3	6	7	12
	4	0	1	1	2	4	6	9
	3	0	1	1	1	4	5	8
	2	0	1	1	1	3	4	7
	1	0	0	1	1	1	3	5
	1/0	0	0	1	1	1	2	4
	2/0	0	0	1	1	1	1	3
	3/0	0	0	0	1	1	1	3
	4/0	0	0	0	1	1	1	2
	250	0	0	0	0	1	1	1
	300	0	0	0	0	1	1	1
	350	0	0	0	0	1	1	1
400	0	0	0	0	1	1	1	
500	0	0	0	0	1	1	1	
600	0	0	0	0	0	1	1	
TW	14	5	9	15	25	44	57	93
	12	4	7	12	19	33	43	71
	10	3	5	9	14	25	32	53
	8	1	3	5	8	14	18	29
RHH†, RHW†, RHW-2†, THHW, THW, THW-2	14	3	6	10	16	29	38	62
	12	3	5	8	13	23	30	50
RHH†, RHW†, RHW-2†, THHW, THW	10	1	3	6	10	18	23	39
	8	1	1	4	6	11	14	23
RHH†, RHW†, RHW-2†, TW, THW, THHW, THW-2	6	1	1	3	5	8	11	18
	4	1	1	1	3	6	8	13
	3	1	1	1	3	5	7	11
	2	0	1	1	2	4	6	9
	1	0	1	1	1	3	4	7
	1/0	0	0	1	1	2	3	6
	2/0	0	0	1	1	2	3	5
	3/0	0	0	1	1	1	2	4
	4/0	0	0	0	1	1	1	3
	250	0	0	0	1	1	1	3
300	0	0	0	1	1	1	2	
350	0	0	0	0	1	1	1	
400	0	0	0	0	1	1	1	
500	0	0	0	0	1	1	1	
600	0	0	0	0	1	1	1	
THHN, THWN, THWN-2	14	8	13	22	36	63	81	133
	12	5	9	16	26	46	59	97
	10	3	6	10	16	29	37	61
	8	1	3	6	9	16	21	35
	6	1	2	4	7	12	15	25
	4	1	1	2	4	7	9	15
	3	1	1	1	3	6	8	13
	2	1	1	1	3	5	7	11
	1	0	1	1	1	4	5	8
	1/0	0	1	1	1	3	4	7
	2/0	0	0	1	1	2	3	6
	3/0	0	0	1	1	1	3	5
	4/0	0	0	1	1	1	2	4
	250	0	0	0	1	1	1	3
	300	0	0	0	1	1	1	3
	350	0	0	0	1	1	1	2
400	0	0	0	0	1	1	1	
500	0	0	0	0	1	1	1	
600	0	0	0	0	1	1	1	

Table C.5 Continued

CONDUCTORS								
Type	Conductor Size (AWG/kcmil)	Metric Designator (Trade Size)						
		12 (3/8)	16 (1/2)	21 (3/4)	27 (1)	35 (1 1/4)	41 (1 1/2)	53 (2)
XHH, XHHW, XHHW-2	14	5	9	15	25	44	57	93
	12	4	7	12	19	33	43	71
	10	3	5	9	14	25	32	53
	8	1	3	5	8	14	18	29
	6	1	1	3	6	10	13	22
	4	1	1	2	4	7	9	16
	3	1	1	1	3	6	8	13
	2	1	1	1	3	5	7	11
	1	0	1	1	1	4	5	8
	1/0	0	1	1	1	3	4	7
	2/0	0	0	1	1	2	3	6
	3/0	0	0	1	1	1	3	5
	4/0	0	0	1	1	1	2	4
	250	0	0	0	1	1	1	3
	300	0	0	0	1	1	1	3
	350	0	0	0	1	1	1	2
400	0	0	0	0	1	1	1	
500	0	0	0	0	1	1	1	
600	0	0	0	0	1	1	1	

Notes:
 1. This table is for concentric stranded conductors only. For compact stranded conductors, Table C.5(A) should be used.
 2. Two-hour fire-rated RHH cable has ceramifiable insulation which has much larger diameters than other RHH wires.
 Consult manufacturer's conduit fill tables.
 *Corresponds to 356.2(2).
 †Types RHH, RHW, and RHW-2 without outer covering.

Table C.5(A) Maximum Number of Compact Conductors in Liquidtight Flexible Nonmetallic Conduit (Type LFNC-B*) (Based on Table 1, Chapter 9)

COMPACT CONDUCTORS								
Type	Conductor Size (AWG/kcmil)	Metric Designator (Trade Size)						
		12 (3/8)	16 (1/2)	21 (3/4)	27 (1)	35 (1 1/4)	41 (1 1/2)	53 (2)
THW, THW-2, THHW	8	1	2	4	7	12	15	25
	6	1	1	3	5	9	12	19
	4	1	1	2	4	7	9	14
	2	1	1	1	3	5	6	11
	1	0	1	1	1	3	4	7
	1/0	0	1	1	1	3	4	6
	2/0	0	0	1	1	2	3	5
	3/0	0	0	1	1	1	3	4
	4/0	0	0	1	1	1	2	4
	250	0	0	0	1	1	1	3
	300	0	0	0	1	1	1	2
	350	0	0	0	1	1	1	2
	400	0	0	0	0	1	1	1
	500	0	0	0	0	1	1	1
	600	0	0	0	0	1	1	1
	THHN, THWN, THWN-2	8	—	—	—	—	—	—
6		1	2	4	7	13	17	28
4		1	1	3	4	8	11	17
2		1	1	1	3	6	7	12
1		0	1	1	2	4	6	9
1/0		0	1	1	1	4	5	8
2/0		0	1	1	1	3	4	6
3/0		0	0	1	1	2	3	5
4/0		0	0	1	1	1	3	4
250		0	0	1	1	1	1	3
300		0	0	0	1	1	1	3
350		0	0	0	1	1	1	2
400		0	0	0	1	1	1	2
500		0	0	0	0	1	1	1
600		0	0	0	0	1	1	1
XHHW, XHHW-2		8	1	3	5	9	15	20
	6	1	2	4	6	11	15	24
	4	1	1	3	4	8	11	17
	2	1	1	1	3	6	7	12
	1	0	1	1	2	4	6	9
	1/0	0	1	1	1	4	5	8
	2/0	0	1	1	1	3	4	7
	3/0	0	0	1	1	2	3	5
	4/0	0	0	1	1	1	3	4
	250	0	0	1	1	1	1	3
	300	0	0	0	1	1	1	3
	350	0	0	0	1	1	1	3
	400	0	0	0	1	1	1	2
	500	0	0	0	0	1	1	1
	600	0	0	0	0	1	1	1

*Corresponds to 356.2(2).
 Definition: Compact stranding is the result of a manufacturing process where the standard conductor is compressed to the extent that the interstices (voids between strand wires) are virtually eliminated.

Table C.6 Maximum Number of Conductors in Liquidtight Flexible Nonmetallic Conduit (Type LFNC-A*) (Based on Table 1, Chapter 9)

CONDUCTORS								
Type	Conductor Size (AWG/kcmil)	Metric Designator (Trade Size)						
		12	16	21	27	35	41	53
		(3/8)	(1/2)	(3/4)	(1)	(1 1/4)	(1 1/2)	(2)
RHH, RHW, RHW-2	14	2	4	7	11	20	27	45
	12	1	3	6	9	17	23	38
	10	1	3	5	8	13	18	30
	8	1	1	2	4	7	9	16
	6	1	1	1	3	5	7	13
	4	0	1	1	2	4	6	10
	3	0	1	1	1	4	5	8
	2	0	1	1	1	3	4	7
	1	0	0	1	1	1	3	5
	1/0	0	0	1	1	1	2	4
	2/0	0	0	1	1	1	1	4
	3/0	0	0	0	1	1	1	3
	4/0	0	0	0	1	1	1	3
	250	0	0	0	0	1	1	1
	300	0	0	0	0	1	1	1
350	0	0	0	0	1	1	1	
400	0	0	0	0	1	1	1	
500	0	0	0	0	0	1	1	
600	0	0	0	0	0	1	1	
TW	14	5	9	15	24	43	58	96
	12	4	7	12	19	33	44	74
	10	3	5	9	14	24	33	55
	8	1	3	5	8	13	18	30
RHH†, RHW†, RHW-2†, THHW, THW, THW-2	14	3	6	10	16	28	38	64
	12	3	4	8	13	23	31	51
RHH†, RHW†, RHW-2†, THHW, THW	10	1	3	6	10	18	24	40
	8	1	1	4	6	10	14	24
RHH†, RHW†, RHW-2†, THHW, THW, THW-2	6	1	1	3	4	8	11	18
	4	1	1	1	3	6	8	13
	3	1	1	1	3	5	7	11
	2	0	1	1	2	4	6	10
	1	0	1	1	1	3	4	7
	1/0	0	0	1	1	2	3	6
	2/0	0	0	1	1	1	3	5
	3/0	0	0	1	1	1	2	4
	4/0	0	0	0	1	1	1	3
	250	0	0	0	1	1	1	3
	300	0	0	0	1	1	1	2
	350	0	0	0	0	1	1	1
	400	0	0	0	0	1	1	1
	500	0	0	0	0	1	1	1
	600	0	0	0	0	1	1	1
THHN, THWN, THWN-2	14	8	13	22	35	62	83	137
	12	5	9	16	25	45	60	100
	10	3	6	10	16	28	38	63
	8	1	3	6	9	16	22	36
	6	1	2	4	6	12	16	26
	4	1	1	2	4	7	9	16
	3	1	1	1	3	6	8	13
	2	1	1	1	3	5	7	11
	1	0	1	1	1	4	5	8
	1/0	0	1	1	1	3	4	7
	2/0	0	0	1	1	2	3	6
	3/0	0	0	1	1	1	3	5
	4/0	0	0	1	1	1	2	4
	250	0	0	0	1	1	1	3
	300	0	0	0	1	1	1	3
350	0	0	0	1	1	1	2	
400	0	0	0	0	1	1	1	
500	0	0	0	0	1	1	1	
600	0	0	0	0	1	1	1	

Table C.6 Continued

CONDUCTORS								
Type	Conductor Size (AWG/kcmil)	Metric Designator (Trade Size)						
		12	16	21	27	35	41	53
		(3/8)	(1/2)	(3/4)	(1)	(1 1/4)	(1 1/2)	(2)
XHH, XHHW, XHHW-2	14	5	9	15	24	43	58	96
	12	4	7	12	19	33	44	74
	10	3	5	9	14	24	33	55
	8	1	3	5	8	13	18	30
	6	1	1	3	5	10	13	22
	4	1	1	2	4	7	10	16
	3	1	1	1	3	6	8	14
	2	1	1	1	3	5	7	11
	1	0	1	1	1	4	5	8
	1/0	0	1	1	1	3	4	7
	2/0	0	0	1	1	2	3	6
	3/0	0	0	1	1	1	3	5
	4/0	0	0	1	1	1	2	4
	250	0	0	0	1	1	1	3
	300	0	0	0	1	1	1	3
350	0	0	0	1	1	1	2	
400	0	0	0	0	1	1	1	
500	0	0	0	0	1	1	1	
600	0	0	0	0	1	1	1	

Notes:

1. This table is for concentric stranded conductors only. For compact stranded conductors, Table C.6(A) should be used.

2. Two-hour fire-rated RHH cable has ceramic insulation which has much larger diameters than other RHH wires.

Consult manufacturer's conduit fill tables.

*Corresponds to 356.2(1).

†Types RHH, RHW, and RHW-2 without outer covering.

Table C.6(A) Maximum Number of Compact Conductors in Liquidtight Flexible Nonmetallic Conduit (Type LFNC-A*) (Based on Table 1, Chapter 9)

COMPACT CONDUCTORS								
Type	Conductor Size (AWG/kcmil)	Metric Designator (Trade Size)						
		12	16	21	27	35	41	53
		(3/8)	(1/2)	(3/4)	(1)	(1 1/4)	(1 1/2)	(2)
THW, THW-2, THHW	8	1	2	4	6	11	16	26
	6	1	1	3	5	9	12	20
	4	1	1	2	4	7	9	15
	2	1	1	1	3	5	6	11
	1	0	1	1	1	3	4	8
	1/0	0	1	1	1	3	4	7
	2/0	0	0	1	1	2	3	5
	3/0	0	0	1	1	1	3	5
	4/0	0	0	1	1	1	2	4
	250	0	0	0	1	1	1	3
	300	0	0	0	1	1	1	3
	350	0	0	0	1	1	1	2
	400	0	0	0	0	1	1	1
	500	0	0	0	0	1	1	1
	600	0	0	0	0	1	1	1
THHN, THWN, THWN-2	8	—	—	—	—	—	—	—
	6	1	2	4	7	13	18	29
	4	1	1	3	4	8	11	18
	2	1	1	1	3	6	8	13
	1	0	1	1	2	4	6	10
	1/0	0	1	1	1	3	5	8
	2/0	0	1	1	1	3	4	7
	3/0	0	0	1	1	2	3	6
	4/0	0	0	1	1	1	3	5
	250	0	0	1	1	1	1	3
	300	0	0	0	1	1	1	3
	350	0	0	0	1	1	1	3
	400	0	0	0	1	1	1	2
	500	0	0	0	0	1	1	1
	600	0	0	0	0	1	1	1
XHHW, XHHW-2	8	1	3	5	8	15	20	34
	6	1	2	4	6	11	15	25
	4	1	1	3	4	8	11	18
	2	1	1	1	3	6	8	13
	1	0	1	1	2	4	6	10
	1/0	0	1	1	1	3	5	8
	2/0	0	1	1	1	3	4	7
	3/0	0	0	1	1	2	3	6
	4/0	0	0	1	1	1	3	5
	250	0	0	1	1	1	2	4
	300	0	0	0	1	1	1	3
	350	0	0	0	1	1	1	3
	400	0	0	0	1	1	1	2
	500	0	0	0	0	1	1	1
	600	0	0	0	0	1	1	1

*Corresponds to 356.2(1).

Definition: *Compact stranding* is the result of a manufacturing process where the standard conductor is compressed to the extent that the interstices (voids between strand wires) are virtually eliminated.

Table C.7 Maximum Number of Conductors in Liquidtight Flexible Metal Conduit (LFMC) (Based on Table 1, Chapter 9)

CONDUCTORS												
Type	Conductor Size (AWG/kcmil)	Metric Designator (Trade Size)										
		16 (1/2)	21 (3/4)	27 (1)	35 (1/4)	41 (1 1/2)	53 (2)	63 (2 1/2)	78 (3)	91 (3 1/2)	103 (4)	
RHH, RHW, RHW-2	14	4	7	12	21	27	44	66	102	133	173	
	12	3	6	10	17	22	36	55	84	110	144	
	10	3	5	8	14	18	29	44	68	89	116	
	8	1	2	4	7	9	15	23	36	46	61	
	6	1	1	3	6	7	12	18	28	37	48	
	4	1	1	2	4	6	9	14	22	29	38	
	3	1	1	1	4	5	8	13	19	25	33	
	2	1	1	1	3	4	7	11	17	22	29	
	1	0	1	1	1	3	5	7	11	14	19	
	1/0	0	1	1	1	2	4	6	10	13	16	
	2/0	0	1	1	1	1	3	5	8	11	14	
	3/0	0	0	1	1	1	3	4	7	9	12	
	4/0	0	0	1	1	1	2	4	6	8	10	
	250	0	0	0	1	1	1	3	4	6	8	
	300	0	0	0	1	1	1	2	4	5	7	
350	0	0	0	1	1	1	2	3	5	6		
400	0	0	0	1	1	1	1	3	4	6		
500	0	0	0	1	1	1	1	3	4	5		
600	0	0	0	0	1	1	1	2	3	4		
TW	14	9	15	25	44	57	93	140	215	280	365	
	12	7	12	19	33	43	71	108	165	215	280	
	10	5	9	14	25	32	53	80	123	160	209	
	8	3	5	8	14	18	29	44	68	89	116	
RHH*, RHW*, RHW-2*, THHW, THW, THW-2	14	6	10	16	29	38	62	93	143	186	243	
	12	5	8	13	23	30	50	75	115	149	195	
RHH*, RHW*, RHW-2*, THHW, THW	10	3	6	10	18	23	39	58	89	117	152	
	8	1	4	6	11	14	23	35	53	70	91	
RHH*, RHW*, RHW-2*, THHW, THW, THW-2	6	1	3	5	8	11	18	27	41	53	70	
	4	1	1	3	6	8	13	20	30	40	52	
	3	1	1	3	5	7	11	17	26	34	44	
	2	1	1	2	4	6	9	14	22	29	38	
	1	1	1	1	3	4	7	10	15	20	26	
	1/0	0	1	1	2	3	6	8	13	17	23	
	2/0	0	1	1	2	3	5	7	11	15	19	
	3/0	0	1	1	1	2	4	6	9	12	16	
	4/0	0	0	1	1	1	3	5	8	10	13	
	250	0	0	1	1	1	3	4	6	8	11	
	300	0	0	1	1	1	2	3	5	7	9	
	350	0	0	0	1	1	1	3	5	6	8	
	400	0	0	0	1	1	1	3	4	6	7	
	500	0	0	0	1	1	1	2	3	5	6	
	600	0	0	0	1	1	1	1	3	4	5	
THHN, THWN, THWN-2	14	13	22	36	63	81	133	201	308	401	523	
	12	9	16	26	46	59	97	146	225	292	381	
	10	6	10	16	29	37	61	92	141	184	240	
	8	3	6	9	16	21	35	53	81	106	138	
	6	2	4	7	12	15	25	38	59	76	100	
	4	1	2	4	7	9	15	23	36	47	61	
	3	1	1	3	6	8	13	20	30	40	52	
	2	1	1	3	5	7	11	17	26	33	44	
	1	1	1	1	4	5	8	12	19	25	32	
	1/0	1	1	1	3	4	7	10	16	21	27	
	2/0	0	1	1	2	3	6	8	13	17	23	
	3/0	0	1	1	1	3	5	7	11	14	19	
	4/0	0	1	1	1	2	4	6	9	12	15	
	250	0	0	1	1	1	3	5	7	10	12	
	300	0	0	1	1	1	3	4	6	8	11	
350	0	0	1	1	1	2	3	5	7	9		
400	0	0	0	1	1	1	3	5	6	8		
500	0	0	0	1	1	1	2	4	5	7		
600	0	0	0	1	1	1	1	3	4	6		

Table C.7 Continued

CONDUCTORS												
Type	Conductor Size (AWG/kcmil)	Metric Designator (Trade Size)										
		16 (1/2)	21 (3/4)	27 (1)	35 (1/4)	41 (1 1/2)	53 (2)	63 (2 1/2)	78 (3)	91 (3 1/2)	103 (4)	
XHH, XHHW, XHHW-2	14	9	15	25	44	57	93	140	215	280	365	
	12	7	12	19	33	43	71	108	165	215	280	
	10	5	9	14	25	32	53	80	123	160	209	
	8	3	5	8	14	18	29	44	68	89	116	
	6	1	3	6	10	13	22	33	50	66	86	
	4	1	2	4	7	9	16	24	36	48	62	
	3	1	1	3	6	8	13	20	31	40	52	
	2	1	1	3	5	7	11	17	26	34	44	
	1	1	1	1	4	5	8	12	19	25	33	
	1/0	1	1	1	3	4	7	10	16	21	28	
	2/0	0	1	1	2	3	6	9	13	17	23	
	3/0	0	1	1	1	3	5	7	11	14	19	
	4/0	0	1	1	1	2	4	6	9	12	16	
	250	0	0	1	1	1	3	5	7	10	13	
	300	0	0	1	1	1	3	4	6	8	11	
350	0	0	1	1	1	2	3	5	7	10		
400	0	0	0	1	1	1	3	5	6	8		
500	0	0	0	1	1	1	2	4	5	7		
600	0	0	0	1	1	1	1	3	4	6		

Notes:

1. This table is for concentric stranded conductors only. For compact stranded conductors, Table C.7(A) should be used.

2. Two-hour fire-rated RHH cable has ceramic insulation which has much larger diameters than other RHH wires.

Consult manufacturer's conduit fill tables.

*Types RHH, RHW, and RHW-2 without outer covering.

Table C.7(A) Maximum Number of Compact Conductors in Liquidtight Flexible Metal Conduit (LFMC) (Based on Table 1, Chapter 9)

COMPACT CONDUCTORS												
Type	Conductor Size (AWG/kcmil)	Metric Designator (Trade Size)										
		12 (3/8)	16 (1/2)	21 (3/4)	27 (1)	35 (1/4)	41 (1 1/2)	53 (2)	63 (2 1/2)	78 (3)	91 (3 1/2)	103 (4)
THW, THW-2, THHW	8	1	2	4	7	12	15	25	38	58	76	99
	6	1	1	3	5	9	12	19	29	45	59	77
	4	1	1	2	4	7	9	14	22	34	44	57
	2	1	1	1	3	5	6	11	16	25	32	42
	1	0	1	1	1	3	4	7	11	17	23	30
	1/0	0	1	1	1	3	4	6	10	15	20	26
	2/0	0	0	1	1	2	3	5	8	13	16	21
	3/0	0	0	1	1	1	3	4	7	11	14	18
	4/0	0	0	1	1	1	2	4	6	9	12	15
	250	0	0	0	1	1	1	3	4	7	9	12
	300	0	0	0	1	1	1	2	4	6	8	10
	350	0	0	0	1	1	1	2	3	5	7	9
	400	0	0	0	0	1	1	1	3	5	6	8
	500	0	0	0	0	1	1	1	3	4	5	7
	600	0	0	0	0	1	1	1	1	3	4	6
THHN, THWN, THWN-2	8	—	—	—	—	—	—	—	—	—	—	—
	6	1	2	4	7	13	17	28	43	66	86	112
	4	1	1	3	4	8	11	17	26	41	53	69
	2	1	1	1	3	6	7	12	19	29	38	50
	1	0	1	1	2	4	6	9	14	22	28	37
	1/0	0	1	1	1	4	5	8	12	19	24	32
	2/0	0	1	1	1	3	4	6	10	15	20	26
	3/0	0	0	1	1	2	3	5	8	13	17	22
	4/0	0	0	1	1	1	3	4	7	10	14	18
	250	0	0	1	1	1	1	3	5	8	11	14
	300	0	0	0	1	1	1	3	4	7	9	12
	350	0	0	0	1	1	1	2	4	6	8	11
	400	0	0	0	1	1	1	2	3	5	7	9
	500	0	0	0	0	1	1	1	3	5	6	8
	600	0	0	0	0	1	1	1	2	4	5	6
XHHW, XHHW-2	8	1	3	5	9	15	20	33	49	76	98	129
	6	1	2	4	6	11	15	24	37	56	73	95
	4	1	1	3	4	8	11	17	26	41	53	69
	2	1	1	1	3	6	7	12	19	29	38	50
	1	0	1	1	2	4	6	9	14	22	28	37
	1/0	0	1	1	1	4	5	8	12	19	24	32
	2/0	0	1	1	1	3	4	7	10	16	20	27
	3/0	0	0	1	1	2	3	5	8	13	17	22
	4/0	0	0	1	1	1	3	4	7	11		

Table C.8 Maximum Number of Conductors in Rigid Metal Conduit (RMC) (Based on Table 1, Chapter 9)

		CONDUCTORS												
		Metric Designator (Trade Size)												
Type	Conductor Size (AWG/kcmil)	16	21	27	35	41	53	63	78	91	103	129	155	(6)
		(1/2)	(3/4)	(1)	(1 1/4)	(1 1/2)	(2)	(2 1/2)	(3)	(3 1/2)	(4)	(5)	(6)	
RHH, RHW, RHW-2	14	4	7	12	21	28	46	66	102	136	176	276	398	
	12	3	6	10	17	23	38	55	85	113	146	229	330	
	10	3	5	8	14	19	31	44	68	91	118	185	267	
	8	1	2	4	7	10	16	23	36	48	61	97	139	
	6	1	1	3	6	8	13	18	29	38	49	77	112	
	4	1	1	2	4	6	10	14	22	30	38	60	87	
	3	1	1	2	4	5	9	12	19	26	34	53	76	
	2	1	1	1	3	4	7	11	17	23	29	46	66	
	1	0	1	1	1	3	5	7	11	15	19	30	44	
	1/0	0	1	1	1	2	4	6	10	13	17	26	38	
	2/0	0	1	1	1	2	4	5	8	11	14	23	33	
	3/0	0	0	1	1	1	3	4	7	10	12	20	28	
	4/0	0	0	1	1	1	3	4	6	8	11	17	24	
	250	0	0	0	1	1	1	3	4	6	8	13	18	
	300	0	0	0	1	1	1	2	4	5	7	11	16	
350	0	0	0	1	1	1	2	4	5	6	10	15		
400	0	0	0	1	1	1	1	3	4	6	9	13		
500	0	0	0	1	1	1	1	3	4	5	8	11		
600	0	0	0	0	1	1	1	2	3	4	6	9		
TW	14	9	15	25	44	59	98	140	216	288	370	581	839	
	12	7	12	19	33	45	75	107	165	221	284	446	644	
	10	5	9	14	25	34	56	80	123	164	212	332	480	
	8	3	5	8	14	19	31	44	68	91	118	185	267	
RHH*, RHW*, RHW-2*, THHW, THW, THW-2	14	6	10	17	29	39	65	93	143	191	246	387	558	
	12	5	8	13	23	32	52	75	115	154	198	311	448	
	10	3	6	10	18	25	41	58	90	120	154	242	350	
	8	1	4	6	11	15	24	35	54	72	92	145	209	
	6	1	3	5	8	11	18	27	41	55	71	111	160	
	4	1	1	3	6	8	14	20	31	41	53	83	120	
	3	1	1	3	5	7	12	17	26	35	45	71	103	
	2	1	1	2	4	6	10	14	22	30	38	60	87	
	1	1	1	1	3	4	7	10	15	21	27	42	61	
	1/0	0	1	1	2	3	6	8	13	18	23	36	52	
2/0	0	1	1	2	3	5	7	11	15	19	31	44		
3/0	0	1	1	1	2	4	6	9	13	16	26	37		
4/0	0	0	1	1	1	3	5	8	10	14	21	31		
250	0	0	1	1	1	3	4	6	8	11	17	25		
300	0	0	1	1	1	2	3	5	7	9	15	22		
350	0	0	0	1	1	1	3	5	6	8	13	19		
400	0	0	0	1	1	1	3	4	6	7	12	17		
500	0	0	0	1	1	1	2	3	5	6	10	14		
600	0	0	0	0	1	1	1	3	4	5	8	12		
THHN, THWN, THWN-2	14	13	22	36	63	85	140	200	309	412	531	833	1202	
	12	9	16	26	46	62	102	146	225	301	387	608	877	
	10	6	10	17	29	39	64	92	142	189	244	383	552	
	8	3	6	9	16	22	37	53	82	109	140	221	318	
	6	2	4	7	12	16	27	38	59	79	101	159	230	
	4	1	2	4	7	10	16	23	36	48	62	98	141	
	3	1	1	3	6	8	14	20	31	41	53	83	120	
	2	1	1	3	5	7	11	17	26	34	44	70	100	
	1	1	1	1	4	5	8	12	19	25	33	51	74	
	1/0	1	1	1	3	4	7	10	16	21	27	43	63	
	2/0	0	1	1	2	3	6	8	13	18	23	36	52	
	3/0	0	1	1	1	3	5	7	11	15	19	30	43	
	4/0	0	1	1	1	2	4	6	9	12	16	25	36	
	250	0	0	1	1	1	3	5	7	10	13	20	29	
	300	0	0	1	1	1	3	4	6	8	11	17	25	
350	0	0	1	1	1	2	3	5	7	10	15	22		
400	0	0	1	1	1	2	3	5	7	8	13	20		
500	0	0	0	1	1	1	2	4	5	7	11	16		
600	0	0	0	0	1	1	1	3	4	6	9	13		

Table C.8 Continued

		CONDUCTORS												
		Metric Designator (Trade Size)												
Type	Conductor Size (AWG/kcmil)	16	21	27	35	41	53	63	78	91	103	129	155	(6)
		(1/2)	(3/4)	(1)	(1 1/4)	(1 1/2)	(2)	(2 1/2)	(3)	(3 1/2)	(4)	(5)	(6)	
XHH, XHHW, XHHW-2, ZW	14	9	15	25	44	59	98	140	216	288	370	581	839	
	12	7	12	19	33	45	75	107	165	221	284	446	644	
	10	5	9	14	25	34	56	80	123	164	212	332	480	
	8	3	5	8	14	19	31	44	68	91	118	185	267	
	6	1	3	6	10	14	23	33	51	68	87	137	197	
	4	1	2	4	7	10	16	24	37	49	63	99	143	
	3	1	1	3	6	8	14	20	31	41	53	84	121	
	2	1	1	3	5	7	12	17	26	35	45	70	101	
	1	1	1	1	4	5	9	12	19	26	33	52	76	
	1/0	1	1	1	3	4	7	10	16	22	28	44	64	
	2/0	0	1	1	2	3	6	9	13	18	23	37	53	
	3/0	0	1	1	1	3	5	7	11	15	19	30	44	
	4/0	0	1	1	1	2	4	6	9	12	16	25	36	
	250	0	0	1	1	1	3	5	7	10	13	20	30	
	300	0	0	1	1	1	3	4	6	9	11	18	25	
	350	0	0	1	1	1	2	3	6	7	10	15	22	
	400	0	0	1	1	1	2	3	5	7	9	14	20	
	500	0	0	0	1	1	1	2	4	5	7	11	16	
	600	0	0	0	0	1	1	1	3	4	6	9	13	

Notes:

1. This table is for concentric stranded conductors only. For compact stranded conductors, Table C.8(A) should be used.
2. Two-hour fire-rated RHH cable has ceramic insulation which has much larger diameters than other RHH wires.

Consult manufacturer's conduit fill tables.

*Types RHH, RHW, and RHW-2 without outer covering.

Table C.8(A) Maximum Number of Compact Conductors in Rigid Metal Conduit (RMC) (Based on Table 1, Chapter 9)

		COMPACT CONDUCTORS												
		Metric Designator (Trade Size)												
Type	Conductor Size (AWG/kcmil)	16	21	27	35	41	53	63	78	91	103	129	155	(6)
		(1/2)	(3/4)	(1)	(1 1/4)	(1 1/2)	(2)	(2 1/2)	(3)	(3 1/2)	(4)	(5)	(6)	
THW, THW-2, THHW	8	2	4	7	12	16	26	38	59	78	101	158	228	
	6	1	3	5	9	12	20	29	45	60	78	122	176	
	4	1	2	4	7	9	15	22	34	45	58	91	132	
	2	1	1	3	5	7	11	16	25	33	43	67	97	
	1	1	1	1	3	5	8	11	17	23	30	47	68	
	1/0	1	1	1	3	4	7	10	15	20	26	41	59	
	2/0	0	1	1	2	3	6	8	13	17	22	34	50	
	3/0	0	1	1	1	3	5	7	11	14	19	29	42	
	4/0	0	1	1	1	2	4	6	9	12	15	24	35	
	250	0	0	1	1	1	3	4	7	9	12	19	28	
300	0	0	1	1	1	3	4	6	8	11	17	24		
350	0	0	1	1	1	2	3	5	7	9	15	22		
400	0	0	1	1	1	1	3	5	7	8	13	20		
500	0	0	0	1	1	1	3	4	5	7	11	17		
600	0	0	0	0	1	1	1	3	4	6	9	13		
THHN, THWN, THWN-2	8	—	—	—	—	—	—	—	—	—	—	—	—	
	6	2	5	8	13	18	30	43	66	88	114	179	258	
	4	1	3	5	8	11	18	26	41	55	70	110	159	
	2	1	1	3	6	8	13	19	29	39	50	79	114	
	1	1	1	2	4	6	10	14	22	29	38	60	86	
	1/0	1	1	1	4	5	8	12	19	25	32	51	73	
	2/0	1	1	1	3	4	7	10	15	21	26	42	60	
	3/0	0	1	1	2	3	6	8	13	17	22	35	51	
	4/0	0	1	1	1	3	5	7	10	14	18	29	42	
	250	0	1	1	1	2	4	5	8	11	14	23	33	
300	0	0	1	1	1	3	4	7	10	12	20	28		
350	0	0	1	1	1	3	4	6	8	11	17	25		
400	0	0	1	1	1	2	3	5	7	10	15	22		
500	0	0	0	1	1	1	3	5	6	8	13	19		
600	0	0	0	0	1	1	1	2	4	5	6	10	15	
XHHW, XHHW-2	8	3	5	9										

Table C.9 Maximum Number of Conductors in Rigid PVC Conduit, Schedule 80 (Based on Table 1, Chapter 9)

CONDUCTORS													
Type	Conductor Size (AWG/kcmil)	Metric Designator (Trade Size)											
		16	21	27	35	41	53	63	78	91	103	129	155
		(1/2)	(3/4)	(1)	(1 1/4)	(1 1/2)	(2)	(2 1/2)	(3)	(3 1/2)	(4)	(5)	(6)
RHH, RHW, RHW-2	14	3	5	9	17	23	39	56	88	118	153	243	349
	12	2	4	7	14	19	32	46	73	98	127	202	290
	10	1	3	6	11	15	26	37	59	79	103	163	234
	8	1	1	3	6	8	13	19	31	41	54	85	122
	6	1	1	2	4	6	11	16	24	33	43	68	98
	4	1	1	1	3	5	8	12	19	26	33	53	77
	3	0	1	1	3	4	7	11	17	23	29	47	67
	2	0	1	1	3	4	6	9	14	20	25	41	58
	1	0	1	1	1	2	4	6	9	13	17	27	38
	1/0	0	0	1	1	1	3	5	8	11	15	23	33
	2/0	0	0	1	1	1	3	4	7	10	13	20	29
	3/0	0	0	1	1	1	3	4	6	8	11	17	25
	4/0	0	0	0	1	1	2	3	5	7	9	15	21
	250	0	0	0	1	1	1	2	4	5	7	11	16
	300	0	0	0	1	1	1	2	3	5	6	10	14
	350	0	0	0	1	1	1	1	3	4	5	9	13
	400	0	0	0	0	1	1	1	3	4	5	8	12
	500	0	0	0	0	1	1	1	2	3	4	7	10
	600	0	0	0	0	0	1	1	1	3	3	6	8
TW	14	6	11	20	35	49	82	118	185	250	324	514	736
	12	5	9	15	27	38	63	91	142	192	248	394	565
	10	3	6	11	20	28	47	67	106	143	185	294	421
	8	1	3	6	11	15	26	37	59	79	103	163	234
RHH*, RHW*, RHW-2*, THHW, THW, THW-2	14	4	8	13	23	32	55	79	123	166	215	341	490
	12	3	6	10	19	26	44	63	99	133	173	274	394
	10	2	5	8	15	20	34	49	77	104	135	214	307
	8	1	3	5	9	12	20	29	46	62	81	128	184
	6	1	1	3	7	9	16	22	35	48	62	98	141
	4	1	1	3	5	7	12	17	26	35	46	73	105
	3	1	1	2	4	6	10	14	22	30	39	63	90
	2	1	1	1	3	5	8	12	19	26	33	53	77
	1	0	1	1	2	3	6	8	13	18	23	37	54
	1/0	0	1	1	1	3	5	7	11	15	20	32	46
	2/0	0	1	1	1	2	4	6	10	13	17	27	39
	3/0	0	0	1	1	1	3	5	8	11	14	23	33
	4/0	0	0	1	1	1	3	4	7	9	12	19	27
	250	0	0	0	1	1	2	3	5	7	9	15	22
	300	0	0	0	1	1	1	3	5	6	8	13	19
	350	0	0	0	1	1	1	2	4	6	7	12	17
	400	0	0	0	1	1	1	2	4	5	7	10	15
	500	0	0	0	1	1	1	1	3	4	5	9	13
	600	0	0	0	0	1	1	1	2	3	4	7	10
THHN, THWN, THWN-2	14	9	17	28	51	70	118	170	265	358	464	736	1055
	12	6	12	20	37	51	86	124	193	261	338	537	770
	10	4	7	13	23	32	54	78	122	164	213	338	485
	8	2	4	7	13	18	31	45	70	95	123	195	279
	6	1	3	5	9	13	22	32	51	68	89	141	202
	4	1	1	3	6	8	14	20	31	42	54	86	124
	3	1	1	3	5	7	12	17	26	35	46	73	105
	2	1	1	2	4	6	10	14	22	30	39	61	88
	1	0	1	1	3	4	7	10	16	22	29	45	65
	1/0	0	1	1	2	3	6	9	14	18	24	38	55
	2/0	0	1	1	1	3	5	7	11	15	20	32	46
	3/0	0	1	1	1	2	4	6	9	13	17	26	38
	4/0	0	0	1	1	1	3	5	8	10	14	22	31
	250	0	0	1	1	1	3	4	6	8	11	18	25
	300	0	0	0	1	1	2	3	5	7	9	15	22
	350	0	0	0	1	1	1	3	5	6	8	13	19
	400	0	0	0	1	1	1	3	4	6	7	12	17
	500	0	0	0	1	1	1	2	3	5	6	10	14
	600	0	0	0	0	1	1	1	3	4	5	8	12

Table C.9 Continued

CONDUCTORS													
Type	Conductor Size (AWG/kcmil)	Metric Designator (Trade Size)											
		16	21	27	35	41	53	63	78	91	103	129	155
		(1/2)	(3/4)	(1)	(1 1/4)	(1 1/2)	(2)	(2 1/2)	(3)	(3 1/2)	(4)	(5)	(6)
XHH, XHHW, XHHW-2	14	6	11	20	35	49	82	118	185	250	324	514	736
	12	5	9	15	27	38	63	91	142	192	248	394	565
	10	3	6	11	20	28	47	67	106	143	185	294	421
	8	1	3	6	11	15	26	37	59	79	103	163	234
	6	1	2	4	8	11	19	28	43	59	76	121	173
	4	1	1	3	6	8	14	20	31	42	55	87	125
	3	1	1	3	5	7	12	17	26	36	47	74	106
	2	1	1	2	4	6	10	14	22	30	39	62	89
	1	0	1	1	3	4	7	10	16	22	29	46	66
	1/0	0	1	1	2	3	6	9	14	19	24	39	56
	2/0	0	1	1	1	3	5	7	11	16	20	32	46
	3/0	0	1	1	1	2	4	6	9	13	17	27	38
	4/0	0	0	1	1	1	3	5	8	11	14	22	32
	250	0	0	1	1	1	3	4	6	9	11	18	26
	300	0	0	1	1	1	2	3	5	7	10	15	22
	350	0	0	0	1	1	1	3	5	6	8	14	20
	400	0	0	0	1	1	1	3	4	6	7	12	17
	500	0	0	0	1	1	1	2	3	5	6	10	14
	600	0	0	0	0	1	1	1	3	4	5	8	11

Notes:
 1. This table is for concentric stranded conductors only. For compact stranded conductors, Table C.9(A) should be used.
 2. Two-hour fire-rated RHH cable has ceramic insulation which has much larger diameters than other RHH wires.
 Consult manufacturer's conduit fill tables.
 *Types RHH, RHW, and RHW-2 without outer covering.

Table C.9(A) Maximum Number of Compact Conductors in Rigid PVC Conduit, Schedule 80 (Based on Table 1, Chapter 9)

COMPACT CONDUCTORS														
Type	Conductor Size (AWG/kcmil)	Metric Designator (Trade Size)												
		16	21	27	35	41	53	63	78	91	103	129	155	
		(1/2)	(3/4)	(1)	(1 1/4)	(1 1/2)	(2)	(2 1/2)	(3)	(3 1/2)	(4)	(5)	(6)	
THW, THW-2, THHW	8	1	3	5	9	13	22	32	50	68	88	140	200	
	6	1	2	4	7	10	17	25	39	52	68	108	155	
	4	1	1	3	5	7	13	18	29	39	51	81	116	
	2	1	1	1	4	5	9	13	21	29	37	60	85	
	1	0	1	1	3	4	6	9	15	20	26	42	60	
	1/0	0	1	1	2	3	6	8	13	17	23	36	52	
	2/0	0	1	1	1	3	5	7	11	15	19	30	44	
	3/0	0	0	1	1	2	4	6	9	12	16	26	37	
	4/0	0	0	1	1	1	3	5	8	10	13	22	31	
	250	0	0	1	1	1	2	4	6	8	11	17	25	
	300	0	0	0	1	1	2	3	5	7	9	15	21	
	350	0	0	0	1	1	1	3	5	6	8	13	19	
	400	0	0	0	1	1	1	3	4	6	7	12	17	
	500	0	0	0	1	1	1	2	3	5	6	10	14	
	600	0	0	0	0	1	1	1	3	4	5	8	12	
	THHN, THWN, THWN-2	8	1	3	6	11	15	25	36	57	77	99	158	226
		4	1	1	3	6	9	15	22	35	47	61	98	140
		2	1	1	2	5	6	11	16	25	34	44	70	100
		1	1	1	1	3	5	8	12	19	25	33	53	75
1/0		0	1	1	3	4	7	10	16	22	28	45	64	
2/0		0	1	1	2	3	6	8	13	18	23	37	53	
3/0		0	1	1	1	3	5	7	11	15	19	31	44	
4/0		0	0	1	1	2	4	6	9	12	16	25	37	
250		0	0	1	1	1	3	4	7	10	12	20	29	
300		0	0	1	1	1	3	4	6	8	11	17	25	
350		0	0	0	1	1	2	3	5	7	9	15	22	
400		0	0	0	1	1	1	3	5	6	8	13	19	
500		0	0	0	1	1	1	2	4	5	7	11	16	
600		0	0	0	1	1	1	1	3	4	6	9	13	
XHHW, XHHW-2		8	1	4	7	12	17	29	42	65	88	114	181	260
		6	1	3	5	9	13	21	31	48	65	85	134	193
		4	1	1	3	6	9	15	22	35	47	61	98	140
		2	1	1	2	5	6	11	16	25	34	44	70	100
		1	1	1	1	3	5	8	12	19	25	33	53	75
	1/0	0	1	1	3	4	7	10	16	22	28	45	64	
	2/0	0	1	1	2	3	6	8	13	18	24	38	54	
	3/0	0	1	1										

Table C.10(A) Maximum Number of Compact Conductors in Rigid PVC Conduit, Schedule 40 and HDPE Conduit (Based on Table 1, Chapter 9)

COMPACT CONDUCTORS													
Type	Conductor Size (AWG/kcmil)	Metric Designator (Trade Size)											
		16 (1/2)	21 (3/4)	27 (1)	35 (1 1/4)	41 (1 1/2)	53 (2)	63 (2 1/2)	78 (3)	91 (3 1/2)	103 (4)	129 (5)	155 (6)
THW, THW-2, THHW	8	1	4	6	11	15	26	37	57	76	98	155	224
	6	1	3	5	9	12	20	28	44	59	76	119	173
	4	1	1	3	6	9	15	21	33	44	57	89	129
	2	1	1	2	5	6	11	15	24	32	42	66	95
	1	1	1	1	3	4	7	11	17	23	29	46	67
	1/0	0	1	1	3	4	6	9	15	20	25	40	58
	2/0	0	1	1	2	3	5	8	12	16	21	34	49
	3/0	0	1	1	1	3	5	7	10	14	18	29	42
	4/0	0	1	1	1	2	4	5	9	12	15	24	35
	250	0	0	1	1	1	3	4	7	9	12	19	27
	300	0	0	1	1	1	2	4	6	8	10	16	24
	350	0	0	1	1	1	2	3	5	7	9	15	21
	400	0	0	0	1	1	1	3	5	6	8	13	19
	500	0	0	0	1	1	1	2	4	5	7	11	16
	600	0	0	0	1	1	1	1	3	4	5	9	13
THHN, THWN, THWN-2	8	—	—	—	—	—	—	—	—	—	—	—	—
	6	2	4	7	13	17	29	41	64	86	111	175	253
	4	1	2	4	8	11	18	25	40	53	68	108	156
	2	1	1	3	5	8	13	18	28	38	49	77	112
	1	1	1	2	4	6	9	14	21	29	37	58	84
	1/0	1	1	1	3	5	8	12	18	24	31	49	72
	2/0	0	1	1	3	4	7	9	15	20	26	41	59
	3/0	0	1	1	2	3	5	8	12	17	22	34	50
	4/0	0	1	1	1	3	4	6	10	14	18	28	41
	250	0	0	1	1	1	3	5	8	11	14	22	32
	300	0	0	1	1	1	3	4	7	9	12	19	28
	350	0	0	1	1	1	3	4	6	8	10	17	24
	400	0	0	1	1	1	2	3	5	7	9	15	22
	500	0	0	0	1	1	1	3	4	6	8	13	18
	600	0	0	0	1	1	1	2	4	5	6	10	15
XHHW, XHHW-2	8	3	5	8	14	20	33	47	73	99	127	200	290
	6	1	4	6	11	15	25	35	55	73	94	149	215
	4	1	2	4	8	11	18	25	40	53	68	108	156
	2	1	1	3	5	8	13	18	28	38	49	77	112
	1	1	1	2	4	6	9	14	21	29	37	58	84
	1/0	1	1	1	3	5	8	12	18	24	31	49	72
	2/0	1	1	1	3	4	7	10	15	20	26	42	60
	3/0	0	1	1	2	3	5	8	12	17	22	34	50
	4/0	0	1	1	1	3	5	7	10	14	18	29	42
	250	0	0	1	1	1	4	5	8	11	14	23	33
	300	0	0	1	1	1	3	4	7	9	12	19	28
	350	0	0	1	1	1	3	4	6	8	11	17	25
	400	0	0	1	1	1	2	3	5	7	10	15	22
	500	0	0	0	1	1	1	3	4	6	8	13	18
	600	0	0	0	1	1	1	2	4	5	6	10	15

Definition: Compact stranding is the result of a manufacturing process where the standard conductor is compressed to the extent that the interstices (voids between strand wires) are virtually eliminated.

Annex D Examples

This annex is not a part of the requirements of this NFPA document but is included for informational purposes only.

Selection of Conductors. In the following examples, the results are generally expressed in amperes (A). To select conductor sizes, refer to the 0 through 2000 volt (V) ampacity tables of Article 310 and the rules of 310.15 that pertain to these tables.

Voltage. For uniform application of Articles 210, 215, and 220, a nominal voltage of 120, 120/240, 240, and 208Y/120 V is used in computing the ampere load on the conductor.

Fractions of an Ampere. Except where the computations result in a major fraction of an ampere (0.5 or larger), such fractions are permitted to be dropped.

Power Factor. Calculations in the following examples are based, for convenience, on the assumption that all loads have the same power factor (PF).

Ranges. For the computation of the range loads in these examples, Column C of Table 220.19 has been used. For optional methods, see Columns A and B of Table 220.19. Except where the computations result in a major fraction of a kilowatt (0.5 or larger), such fractions are permitted to be dropped.

SI Units. For metric conversions, $0.093 \text{ m}^2 = 1 \text{ ft}^2$ and $0.3048 \text{ m} = 1 \text{ ft}$.

Example D1(a) One-Family Dwelling

The dwelling has a floor area of 1500 ft², exclusive of an unfinished cellar not adaptable for future use, unfinished attic, and open porches. Appliances are a 12-kW range and a 5.5-kW, 240-V dryer. Assume range and dryer kW ratings equivalent to kVA ratings in accordance with 220.18 and 220.19.

Computed Load [see 220.40]

General Lighting Load: 1500 ft² at 3 VA per ft² = 4500 VA

Minimum Number of Branch Circuits Required [see 210.11(A)]

General Lighting Load: 4500 VA ÷ 120 V = 37.5 A

This requires three 15-A, 2-wire or two 20-A, 2-wire circuits.

Small Appliance Load: Two 2-wire, 20-A circuits [see 210.11(C)(1)]

Laundry Load: One 2-wire, 20-A circuit [see 210.11(C)(2)]

Bathroom Branch Circuit: One 2-wire, 20-A circuit (no additional load calculation is required for this circuit) [see 210.11(C)(3)]

Minimum Size Feeder Required [see 220.40]

General Lighting	4500 VA
Small Appliance	3000 VA
Laundry	1500 VA
	Total 9000 VA
3000 VA at 100%	3000 VA
9000 VA 3000 VA = 6000 VA at 35%	2100 VA
	Net Load 5100 VA
Range (see Table 220.55)	8000 VA
Dryer Load (see Table 220.54)	5500 VA
	Net Computed Load 18,600 VA

Net Computed Load for 120/240-V, 3-wire, single-phase service or feeder

$$18,600 \text{ VA} \div 240 \text{ V} = 77.5 \text{ A}$$

Sections 230.42(B) and 230.79 require service conductors and disconnecting means rated not less than 100 amperes.

Calculation for Neutral for Feeder and Service

Lighting and Small Appliance Load	5100 VA
Range: 8000 VA at 70% (see 220.61)	5600 VA
Dryer: 5500 VA at 70% (see 220.61)	3850 VA
	Total 14,550 VA

Computed Load for Neutral

$$14,550 \text{ VA} \div 240 \text{ V} = 60.6 \text{ A}$$

Example D1(b) One-Family Dwelling

Assume same conditions as Example No. D1(a), plus addition of one 6-A, 230-V, room air-conditioning unit and one 12-A, 115-V, room air-conditioning unit,* one 8-A, 115-V, rated waste disposer, and one 10-A, 120-V, rated dishwasher. See Article 430 in the NEC for general motors and Article 440, Part VII, for air-conditioning equipment. Motors have nameplate ratings of 115 V and 230 V for use on 120-V and 240-V nominal voltage systems.

*(For feeder neutral, use larger of the two appliances for unbalance.)

From Example D1(a), feeder current is 78 A (3-wire, 240 V).

	Line A	Neutral	Line B
Amperes from Example D1(a)	78	61	78
One 230-V air conditioner	6		6
One 115-V air conditioner and 120-V dishwasher	12	12	10
One 115-V disposer		8	8
25% of largest motor (see 430.24 in the NEC)	3	3	2
Total amperes per line	99	84	104

Therefore, the service would be rated 110 A.

Example D2(a) Optional Calculation for One-Family Dwelling, Heating Larger Than Air Conditioning [see 220.82]

The dwelling has a floor area of 1500 ft², exclusive of an unfinished cellar not adaptable for future use, unfinished attic, and open porches. It has a 12-kW range, a 2.5-kW water heater, a 1.2-kW dishwasher, 9 kW of electric space heating installed in five rooms, a 5-kW clothes dryer, and a 6-A, 230-V, room air-conditioning unit. Assume range, water heater, dishwasher, space heating, and clothes dryer kW ratings equivalent to kVA.

Air Conditioner kVA Calculation

$$6 \text{ A} \times 230 \text{ V} \div 1000 = 1.38 \text{ kVA}$$

This 1.38 kVA [item 1 from 220.82(C)] is less than 40% of 9 kVA of separately controlled electric heat [item 6 from 220.82(C)], so the 1.38 kVA need not be included in the service calculation.

General Load

1500 ft ² at 3 VA	4500 VA
Two 20-A appliance outlet circuits at 1500 VA each	3000 VA
Laundry circuit	1500 VA
Range (at nameplate rating)	12,000 VA
Water heater	2500 VA
Dishwasher	1200 VA
Clothes dryer	5000 VA
	Total 29,700 VA

Application of Demand Factor [see 220.82(B)]

First 10 kVA of general load at 100%	10,000 VA
Remainder of general load at 40% (19.7 kVA × 0.4)	7880 VA
	Total of general load 17,880 VA
9 kVA of heat at 40% (9000 VA × 0.4) =	3600 VA
	Total 21,480 VA

Calculated Load for Service Size

$$21.48 \text{ kVA} = 21,480 \text{ VA}$$

$$21,480 \text{ VA} \div 240 \text{ V} = 89.5 \text{ A}$$

Therefore, the minimum service rating would be 100 A in accordance with 230.42 and 230.79.

Feeder Neutral Load, per 220.61

1500 ft ² at 3 VA	4500 VA	
Three 20-A circuits at 1500 VA	4500 VA	
	<u>9000 VA</u>	Total
3000 VA at 100%	3000 VA	
9000 VA 3000 VA = 6000 VA at 35%		
	<u>2100 VA</u>	
	5100 VA	Subtotal
Range: 8 kVA at 70%	5600 VA	
Clothes dryer: 5 kVA at 70%	3500 VA	
Dishwasher	<u>1200 VA</u>	
	15,400 VA	Total

Calculated Load for Neutral

$$15,400 \text{ VA} \div 240 \text{ V} = 64.2 \text{ A}$$

Example D2(b) Optional Calculation for One-Family Dwelling, Air Conditioning Larger Than Heating [see 220.82(A) and 220.82(C)]

The dwelling has a floor area of 1500 ft², exclusive of an unfinished cellar not adaptable for future use, unfinished attic, and open porches. It has two 20-A small appliance circuits, one 20-A laundry circuit, two 4-kW wall-mounted ovens, one 5.1-kW counter-mounted cooking unit, a 4.5-kW water heater, a 1.2-kW dishwasher, a 5-kW combination clothes washer and dryer, six 7-A, 230-V room air-conditioning units, and a 1.5-kW permanently installed bathroom space heater. Assume wall-mounted ovens, counter-mounted cooking unit, water heater, dishwasher, and combination clothes washer and dryer kW ratings equivalent to kVA.

Air Conditioning kVA Calculation

$$\text{Total amperes} = 6 \text{ units} \times 7 \text{ A} = 42 \text{ A}$$

$$42 \text{ A} \times 240 \text{ V} \div 1000 = 10.08 \text{ kVA (assume PF} = 1.0)$$

Load Included at 100%

Air Conditioning: Included below [see item 1 in 220.82(C)]

Space Heater: Omit [see item 5 in 220.82(C)]

General Load

1500 ft ² at 3 VA	4500 VA	
Two 20-A small appliance circuits at 1500 VA each	3000 VA	
Laundry circuit	1500 VA	
Two ovens	8000 VA	
One cooking unit	5100 VA	
Water heater	4500 VA	
Dishwasher	1200 VA	
Washer/dryer	<u>5000 VA</u>	
	32,800 VA	Total general load
First 10 kVA at 100%	10,000 VA	
Remainder at 40% (22.8 kVA × 0.4 × 1000)	<u>9120 VA</u>	
	19,120 VA	Subtotal general load
Air conditioning	<u>10,080 VA</u>	
Total	29,200 VA	

Calculated Load for Service

$$29,200 \text{ VA} \div 240 \text{ V} = 122 \text{ A (service rating)}$$

Feeder Neutral Load, per 220.61.

Assume that the two 4-kVA wall-mounted ovens are supplied by one branch circuit, the 5.1-kVA counter-mounted cooking unit by a separate circuit.

1500 ft ² at 3 VA	4500 VA	
Three 20-A circuits at 1500 VA	4500 VA	
	<u>9000 VA</u>	Subtotal
3000 VA at 100%	3000 VA	
9000 VA 3000 VA = 6000 VA at 35%	<u>2100 VA</u>	
	5100 VA	Subtotal

Two 4-kVA ovens plus one 5.1-kVA cooking unit = 13.1 kVA. Table 220.55 permits 55% demand factor or 13.1 kVA × 0.55 = 7.2 kVA feeder capacity.

	5100 VA	Subtotal from above
Ovens and cooking unit: 7200 VA × 70% for neutral load	5040 VA	
Clothes washer/dryer: 5 kVA × 70% for neutral load	3500 VA	
Dishwasher	<u>1200 VA</u>	
	14,840 VA	Total

Calculated Load for Neutral

$$14,840 \text{ VA} \div 240 \text{ V} = 61.83 \text{ A (use 62 A)}$$

Example D2(c) Optional Calculation for One-Family Dwelling with Heat Pump (Single-Phase, 240/120-Volt Service) (see 220.82)

The dwelling has a floor area of 2000 ft², exclusive of an unfinished cellar not adaptable for future use, unfinished attic, and open porches. It has a 12-kW range, a 4.5-kW water heater, a 1.2-kW dishwasher, a 5-kW clothes dryer, and a 2½-ton (24-A) heat pump with 15 kW of backup heat.

Heat Pump kVA Calculation

$$24 \text{ A} \times 240 \text{ V} \div 1000 = 5.76 \text{ kVA}$$

This 5.76 kVA is less than 15 kVA of the backup heat; therefore, the heat pump load need not be included in the service calculation [see 220.82(C)].

General Load

2000 ft ² at 3 VA	6000 VA	
Two 20-A appliance outlet circuits at 1500 VA each	3000 VA	
Laundry circuit	1500 VA	
Range (at nameplate rating)	12,000 VA	
Water heater	4500 VA	
Dishwasher	1200 VA	
Clothes dryer	<u>5000 VA</u>	
	33,200 VA	Subtotal general load
First 10 kVA at 100%	10,000 VA	
Remainder of general load at 40% (23,200 VA × 0.4)	<u>9280 VA</u>	
	19,280 VA	Total net general load

Heat Pump and Supplementary Heat*

$$240 \text{ V} \times 24 \text{ A} = 5760 \text{ VA}$$

15-kW Electric Heat:

$$5760 \text{ VA} + (15,000 \text{ VA} \times 65\%) = 5.76 \text{ kVA} + 9.75 \text{ kVA} = 15.51 \text{ kVA}$$

*If supplementary heat is not on at same time as heat pump, heat pump kVA need not be added to total.

Totals

Net general load	19,280 VA
Heat pump and supplementary heat	<u>15,510 VA</u>
Total	34,790 VA

Calculated Load for Service

$$34.79 \text{ kVA} \times 1000 \div 240 \text{ V} = 144.96 \text{ A}$$

Therefore, this dwelling unit would be permitted to be served by a 150-A service.

Annex G

This article is informative unless specifically adopted by the local jurisdiction adopting the National Electrical Code® Requirements for One- and Two-Family Dwellings. (See 80.5.)

<p>ARTICLE 80 Administration and Enforcement</p>
--

80.1 Scope. The following functions are covered:

- (1) The inspection of electrical installations as covered by 90.2
- (2) The investigation of fires caused by electrical installations
- (3) The review of construction plans, drawings, and specifications for electrical systems
- (4) The design, alteration, modification, construction, maintenance, and testing of electrical systems and equipment
- (5) The regulation and control of electrical installations at special events including but not limited to exhibits, trade shows, amusement parks, and other similar special occupancies

80.2 Definitions.

Authority Having Jurisdiction. The organization, office, or individual responsible for approving equipment, materials, an installation, or a procedure.

Chief Electrical Inspector. An electrical inspector who either is the authority having jurisdiction or is designated by the authority having jurisdiction and is responsible for administering the requirements of this *Code*.

Electrical Inspector. An individual meeting the requirements of 80.27 and authorized to perform electrical inspections.

80.3 Purpose. The purpose of this article shall be to provide requirements for administration and enforcement of the *National Electrical Code Requirements for One- and Two-Family Dwellings*.

80.5 Adoption. Article 80 shall not apply unless specifically adopted by the local jurisdiction adopting the *National Electrical Code Requirements for One- and Two-Family Dwellings*.

80.7 Title. The title of this *Code* shall be NFPA 70A, *National Electrical Code® Requirements for One- and Two-Family Dwellings*, of the National Fire Protection Association.

80.9 Application.

(A) New Installations. This *Code* applies to new installations. Buildings with construction permits dated after adoption of this *Code* shall comply with its requirements.

(B) Existing Installations. Existing electrical installations that do not comply with the provisions of this *Code* shall be permitted to be continued in use unless the authority having jurisdiction determines that the lack of conformity with this *Code* presents an imminent danger to occupants. Where changes are required for correction of hazards, a reasonable amount of time shall be given for compliance, depending on the degree of the hazard.

(C) Additions, Alterations, or Repairs. Additions, alterations, or repairs to any building, structure, or premises shall conform to that required of a new building without requiring the existing building to comply with all the requirements of this *Code*. Additions, alterations, installations, or repairs shall not cause an existing building to become unsafe or to adversely affect the performance of the building as determined by the authority having jurisdiction. Electrical wiring added to an existing service, feeder, or branch circuit shall not result in an installation that violates the provisions of the *Code* in force at the time the additions are made.

80.11 Occupancy of Building or Structure.

(A) New Construction. No newly constructed building shall be occupied in whole or in part in violation of the provisions of this *Code*.

(B) Existing Buildings. Existing buildings that are occupied at the time of adoption of this *Code* shall be permitted to remain in use provided the following conditions apply:

- (1) The occupancy classification remains unchanged
- (2) There exists no condition deemed hazardous to life or property that would constitute an imminent danger

80.13 Authority. Where used in this article, the term *authority having jurisdiction* shall include the chief electrical inspector or other individuals designated by the governing body. This *Code* shall be administered and enforced by the authority having jurisdiction designated by the governing authority as follows.

- (1) The authority having jurisdiction shall be permitted to render interpretations of this *Code* in order to provide clarification to its requirements, as permitted by 90.4.
- (2) When the use of any electrical equipment or its installations is found to be dangerous to human life or property, the authority having jurisdiction shall be empowered to have the premises disconnected from its source of electric supply, as established by the Board. When such equipment or installation has been so condemned or disconnected, a notice shall be placed thereon listing the causes for the condemnation, the disconnection, or both and the penalty under 80.23 for the unlawful use thereof. Written notice of such condemnation or disconnection and the causes therefor shall be given within 24 hours to the owners, the occupant, or both, of such building, structure, or premises. It shall be unlawful for any person to remove said notice, to reconnect the electric equipment to its source of electric supply, or to use or permit to be used electric power in any such electric equipment until such causes for the condemnation or disconnection have been remedied to the satisfaction of the inspection authorities.
- (3) The authority having jurisdiction shall be permitted to delegate to other qualified individuals such powers as necessary for the proper administration and enforcement of this *Code*.
- (4) Police, fire, and other enforcement agencies shall have authority to render necessary assistance in the enforcement of this *Code* when requested to do so by the authority having jurisdiction.
- (5) The authority having jurisdiction shall be authorized to inspect, at all reasonable times, any building or premises for dangerous or hazardous conditions or equipment as set forth in this *Code*. The authority having jurisdiction shall be permitted to order any person(s) to remove or remedy such dangerous or hazardous condition or equipment. Any person(s) failing to comply with such order shall be in violation of this *Code*.
- (6) Where the authority having jurisdiction deems that conditions hazardous to life and property exist, he or she shall be permitted to require that such hazardous conditions in violation of this *Code* be corrected.
- (7) To the full extent permitted by law, any authority having jurisdiction engaged in inspection work shall be authorized at all reasonable times to enter and examine any building, structure, or premises for the purpose of making electrical inspections. Before entering a premises, the authority having jurisdiction shall obtain the consent of the occupant thereof or obtain a court warrant authorizing entry for the purpose of inspection except in those instances where an emergency exists. As used in this section, *emergency* means circumstances that the authority having jurisdiction knows, or has reason to believe, exist and that reasonably can constitute immediate danger to persons or property.
- (8) Persons authorized to enter and inspect buildings, structures, and premises as herein set forth shall be identified by proper credentials issued by this governing authority.
- (9) Persons shall not interfere with an authority having jurisdiction carrying out any duties or functions prescribed by this *Code*.
- (10) Persons shall not use a badge, uniform, or other credentials to impersonate the authority having jurisdiction.
- (11) The authority having jurisdiction shall be permitted to investigate the cause, origin, and circumstances of any fire, explosion, or other hazardous condition.
- (12) The authority having jurisdiction shall be permitted to require plans and specifications to ensure compliance with this *Code*.
- (13) Whenever any installation subject to inspection prior to use is covered or concealed without having first been inspected, the authority having jurisdiction shall be permitted to require that such work be exposed for inspection. The authority having jurisdiction shall be notified when the installation is ready for inspection and shall conduct the inspection within _____ days.
- (14) The authority having jurisdiction shall be permitted to order the immediate evacuation of any occupied building deemed unsafe when such building has hazardous conditions that present imminent danger to building occupants.
- (15) The authority having jurisdiction shall be permitted to waive specific requirements in this *Code* or permit alternative methods where it is assured that equivalent objectives can be achieved by establishing and maintaining effective safety. Technical documentation shall be submitted to the authority having jurisdiction to demonstrate equivalency and that the system, method, or device is approved for the intended purpose.
- (16) Each application for a waiver of a specific electrical requirement shall be filed with the authority having jurisdiction and shall be accompanied by such evidence, letters, statements, results of tests, or other supporting information as required to justify the request. The authority having jurisdiction shall keep a record of actions on such applications, and a signed copy of the authority having jurisdiction's decision shall be provided for the applicant.

80.15 Electrical Board.

(A) **Creation of the Electrical Board.** There is hereby created the Electrical Board of the _____ of _____, hereinafter designated as the Board.

(B) **Appointments.** Board members shall be appointed by the Governor with the advice and consent of the Senate (or by the Mayor with the advice and consent of the Council, or the equivalent).

- (1) Members of the Board shall be chosen in a manner to reflect a balanced representation of individuals or organizations. The Chair of the Board shall be elected by the Board membership.
- (2) The Chief Electrical Inspector in the jurisdiction adopting this Article authorized in 80.15(B)(3)(a) shall be the nonvoting secretary of the Board. Where the Chief Electrical Inspector of a local municipality serves a Board at a state level, he or she shall be permitted to serve as a voting member of the Board.
- (3) The board shall consist of not fewer than five voting members. Board members shall be selected from the following:
 - a. Chief Electrical Inspector from a local government (for State Board only)
 - b. An electrical contractor operating in the jurisdiction
 - c. A licensed professional engineer engaged primarily in the design or maintenance of electrical installations
 - d. A journeyman electrician
- (4) Additional membership shall be selected from the following:
 - a. A master (supervising) electrician
 - b. The Fire Marshal (or Fire Chief)
 - c. A representative of the property/casualty insurance industry
 - d. A representative of an electric power utility operating in the jurisdiction
 - e. A representative of electrical manufacturers primarily and actively engaged in producing materials, fittings, devices, appliances, luminaires (fixtures), or apparatus used as part of or in connection with electrical installations
 - f. A member of the labor organization that represents the primary electrical workforce
 - g. A member from the public who is not affiliated with any other designated group
 - h. A representative of a telecommunications utility operating in the jurisdiction

(C) Terms. Of the members first appointed, _____ shall be appointed for a term of 1 year, _____ for a term of 2 years, _____ for a term of 3 years, and _____ for a term of 4 years, and thereafter each appointment shall be for a term of 4 years or until a successor is appointed. The Chair of the Board shall be appointed for a term not to exceed _____ years.

(D) Compensation. Each appointed member shall receive the sum of _____ dollars (\$_____) for each day during which the member attends a meeting of the Board and, in addition thereto, shall be reimbursed for direct lodging, travel, and meal expenses as covered by policies and procedures established by the jurisdiction.

(E) Quorum. A quorum as established by the Board operating procedures shall be required to conduct Board business. The Board shall hold such meetings as necessary to carry out the purposes of Article 80. The Chair or a majority of the members of the Board shall have the authority to call meetings of the Board.

(F) Duties. It shall be the duty of the Board to:

- (1) Adopt the necessary rules and regulations to administer and enforce Article 80.
- (2) Establish qualifications of electrical inspectors.
- (3) Revoke or suspend the recognition of any inspector's certificate for the jurisdiction.
- (4) After advance notice of the public hearings and the execution of such hearings, as established by law, the Board is authorized to establish and update the provisions for the safety of electrical installations to conform with the current edition of the *National Electrical Code Requirements for One- and Two-Family Dwellings* (NFPA 70A) and other nationally recognized safety standards for electrical installations.
- (5) Establish procedures for recognition of electrical safety standards and acceptance of equipment conforming to these standards.

(G) Appeals.

- (1) Review of Decisions. Any person, firm, or corporation may register an appeal with the Board for a review of any decision of the Chief Electrical Inspector or of any Electrical Inspector, provided that such appeal is made in writing within fifteen (15) days after such person, firm, or corporation shall have been notified. Upon receipt of such appeal, said Board shall, if requested by the person making the appeal, hold a public hearing and proceed to determine whether the action of the Board, or of the Chief Electrical Inspector, or of the Electrical Inspector complies with this law and, within fifteen (15) days after receipt of the appeal or after holding the hearing, shall make a decision in accordance with its findings.
- (2) Conditions. Any person shall be permitted to appeal a decision of the authority having jurisdiction to the Board when it is claimed that any one or more of the following conditions exist:
 - a. The true intent of the codes or ordinances described in this *Code* has been incorrectly interpreted.
 - b. The provisions of the codes or ordinances do not fully apply.
 - c. A decision is unreasonable or arbitrary as it applies to alternatives or new materials.
- (3) Submission of Appeals. A written appeal, outlining the *Code* provision from which relief is sought and the remedy proposed, shall be submitted to the authority

having jurisdiction within 15 calendar days of notification of violation.

(H) Meetings and Records. Meetings and records of the Board shall conform to the following:

- (1) Meetings of the Board shall be open to the public as required by law.
- (2) Records of meetings of the Board shall be available for review during normal business hours, as required by law.

80.17 Records and Reports. The authority having jurisdiction shall retain records in accordance with 80.17(A) and (B).

(A) Retention. The authority having jurisdiction shall keep a record of all electrical inspections, including the date of such inspections and a summary of any violations found to exist, the date of the services of notices, and a record of the final disposition of all violations. All required records shall be maintained until their usefulness has been served or as otherwise required by law.

(B) Availability. A record of examinations, approvals, and variances granted shall be maintained by the authority having jurisdiction and shall be available for public review as prescribed by law during normal business hours.

80.19 Permits and Approvals. Permits and approvals shall conform to 80.19(A) through (H).

(A) Application.

- (1) Activity authorized by a permit issued under this *Code* shall be conducted by the permittee or the permittee's agents or employees in compliance with all requirements of this *Code* applicable thereto and in accordance with the approved plans and specifications. No permit issued under this *Code* shall be interpreted to justify a violation of any provision of this *Code* or any other applicable law or regulation. Any addition or alteration of approved plans or specifications shall be approved in advance by the authority having jurisdiction, as evidenced by the issuance of a new or amended permit.
- (2) A copy of the permit shall be posted or otherwise readily accessible at each work site or carried by the permit holder as specified by the authority having jurisdiction.

(B) Content. Permits shall be issued by the authority having jurisdiction and shall bear the name and signature of the authority having jurisdiction or that of the authority having jurisdiction's designated representative. In addition, the permit shall indicate the following:

- (1) Operation or activities for which the permit is issued
- (2) Address or location where the operation or activity is to be conducted

- (3) Name and address of the permittee
- (4) Permit number and date of issuance
- (5) Period of validity of the permit
- (6) Inspection requirements

(C) Issuance of Permits. The authority having jurisdiction shall be authorized to establish and issue permits, certificates, notices, and approvals, or orders pertaining to electrical safety hazards pursuant to 80.23, except that no permit shall be required to execute any of the classes of electrical work specified in the following:

- (1) Installation or replacement of equipment such as lamps and of electric utilization equipment approved for connection to suitable permanently installed receptacles. Replacement of flush or snap switches, fuses, lamp sockets, and receptacles, and other minor maintenance and repair work, such as replacing worn cords and tightening connections on a wiring device
- (2) The process of manufacturing, testing, servicing, or repairing electric equipment or apparatus

(D) Annual Permits. In lieu of an individual permit for each installation or alteration, an annual permit shall, upon application, be issued to any person, firm, or corporation regularly employing one or more employees for the installation, alteration, and maintenance of electric equipment in or on buildings or premises owned or occupied by the applicant for the permit. Upon application, an electrical contractor as agent for the owner or tenant shall be issued an annual permit. The applicant shall keep records of all work done, and such records shall be transmitted periodically to the Electrical Inspector.

(E) Fees. Any political subdivision that has been provided for electrical inspection in accordance with the provisions of Article 80 may establish fees that shall be paid by the applicant for a permit before the permit is issued.

(F) Inspection and Approvals.

- (1) Upon the completion of any installation of electrical equipment that has been made under a permit other than an annual permit, it shall be the duty of the person, firm, or corporation making the installation to notify the Electrical Inspector having jurisdiction, who shall inspect the work within a reasonable time.
- (2) Where the Inspector finds the installation to be in conformity with the statutes of all applicable local ordinances and all rules and regulations, the Inspector shall issue to the person, firm, or corporation making the installation a certificate of approval, with duplicate copy for delivery to the owner, authorizing the connection to the supply of electricity and shall send written notice of such authorization to the supplier of electric service. When a certificate of temporary approval is issued au-

thorizing the connection of an installation, such certificates shall be issued to expire at a time to be stated therein and shall be revocable by the Electrical Inspector for cause.

- (3) When any portion of the electrical installation within the jurisdiction of an Electrical Inspector is to be hidden from view by the permanent placement of parts of the building, the person, firm, or corporation installing the equipment shall notify the Electrical Inspector, and such equipment shall not be concealed until it has been approved by the Electrical Inspector or until _____ days have elapsed from the time of such notification, provided that on large installations, where the concealment of equipment proceeds continuously, the person, firm, or corporation installing the equipment shall give the Electrical Inspector due notice in advance, and inspections shall be made periodically during the progress of the work.
- (4) At regular intervals, the Electrical Inspector having jurisdiction shall visit all buildings and premises where work may be done under annual permits and shall inspect all electric equipment installed under such permits since the date of the previous inspection. The Electrical Inspector shall issue a certificate of approval for such work as is found to be in conformity with the provisions of Article 80 and all applicable ordinances, orders, rules, and regulations, after payments of all required fees.
- (5) If, upon inspection, any installation is found not to be fully in conformity with the provisions of Article 80, and all applicable ordinances, rules, and regulations, the Inspector making the inspection shall at once forward to the person, firm, or corporation making the installation a written notice stating the defects that have been found to exist.

(G) Revocation of Permits. Revocation of permits shall conform to the following:

- (1) The authority having jurisdiction shall be permitted to revoke a permit or approval issued if any violation of this *Code* is found upon inspection or in case there have been any false statements or misrepresentations submitted in the application or plans on which the permit or approval was based.
- (2) Any attempt to defraud or otherwise deliberately or knowingly design, install, service, maintain, operate, sell, represent for sale, falsify records, reports, or applications, or other related activity in violation of the requirements prescribed by this *Code* shall be a violation of this *Code*. Such violations shall be cause for immediate suspension or revocation of any related licenses, certificates, or permits issued by this jurisdiction. In addition, any such violation shall be subject to any other criminal or civil penalties as available by the laws of this jurisdiction.

- (3) Revocation shall be constituted when the permittee is duly notified by the authority having jurisdiction.
- (4) Any person who engages in any business, operation, or occupation, or uses any premises, after the permit issued therefor has been suspended or revoked pursuant to the provisions of this *Code*, and before such suspended permit has been reinstated or a new permit issued, shall be in violation of this *Code*.
- (5) A permit shall be predicated upon compliance with the requirements of this *Code* and shall constitute written authority issued by the authority having jurisdiction to install electrical equipment. Any permit issued under this *Code* shall not take the place of any other license or permit required by other regulations or laws of this jurisdiction.
- (6) The authority having jurisdiction shall be permitted to require an inspection prior to the issuance of a permit.
- (7) A permit issued under this *Code* shall continue until revoked or for the period of time designated on the permit. The permit shall be issued to one person or business only and for the location or purpose described in the permit. Any change that affects any of the conditions of the permit shall require a new or amended permit.

(H) Applications and Extensions. Applications and extensions of permits shall conform to the following:

- (1) The authority having jurisdiction shall be permitted to grant an extension of the permit time period upon presentation by the permittee of a satisfactory reason for failure to start or complete the work or activity authorized by the permit.
- (2) Applications for permits shall be made to the authority having jurisdiction on forms provided by the jurisdiction and shall include the applicant's answers in full to inquiries set forth on such forms. Applications for permits shall be accompanied by such data as required by the authority having jurisdiction, such as plans and specifications, location, and so forth. Fees shall be determined as required by local laws.
- (3) The authority having jurisdiction shall review all applications submitted and issue permits as required. If an application for a permit is rejected by the authority having jurisdiction, the applicant shall be advised of the reasons for such rejection. Permits for activities requiring evidence of financial responsibility by the jurisdiction shall not be issued unless proof of required financial responsibility is furnished.

80.21 Plans Review. Review of plans and specifications shall conform to 80.21(A) through (C).

(A) Authority. For new construction, modification, or rehabilitation, the authority having jurisdiction shall be permitted to review construction documents and drawings.

(B) Responsibility of the Applicant. It shall be the responsibility of the applicant to ensure the following:

- (1) The construction documents include all of the electrical requirements.
- (2) The construction documents and drawings are correct and in compliance with the applicable codes and standards.

(C) Responsibility of the Authority Having Jurisdiction. It shall be the responsibility of the authority having jurisdiction to promulgate rules that cover the following:

- (1) Review of construction documents and drawings within established time frames for the purpose of acceptance or to provide reasons for nonacceptance
- (2) Review and approval by the authority having jurisdiction shall not relieve the applicant of the responsibility of compliance with this *Code*.
- (3) Where field conditions necessitate any substantial change from the approved plan, the authority having jurisdiction shall be permitted to require that the corrected plans be submitted for approval.

80.23 Notice of Violations, Penalties. Notice of violations and penalties shall conform to 80.23(A) and (B).

(A) Violations.

- (1) Whenever the authority having jurisdiction determines that there are violations of this *Code*, a written notice shall be issued to confirm such findings.
- (2) Any order or notice issued pursuant to this *Code* shall be served upon the owner, operator, occupant, or other person responsible for the condition or violation, either by personal service or mail or by delivering the same to, and leaving it with, some person of responsibility upon the premises. For unattended or abandoned locations, a copy of such order or notice shall be posted on the premises in a conspicuous place at or near the entrance to such premises and the order or notice shall be mailed by registered or certified mail, with return receipt requested, to the last known address of the owner, occupant, or both.

(B) Penalties.

- (1) Any person who fails to comply with the provisions of this *Code* or who fails to carry out an order made pursuant to this *Code* or violates any condition attached to a permit, approval, or certificate shall be subject to the penalties established by this jurisdiction.
- (2) Failure to comply with the time limits of an abatement notice or other corrective notice issued by the authority having jurisdiction shall result in each day that such

violation continues being regarded as a new and separate offense.

- (3) Any person, firm, or corporation who shall willfully violate any of the applicable provisions of this article shall be guilty of a misdemeanor and, upon conviction thereof, shall be punished by a fine of not less than _____dollars (\$_____) or more than _____dollars (\$_____) for each offense, together with the costs of prosecution, imprisonment, or both, for not less than _____(_____) days or more than _____(_____) days.

80.25 Connection to Electricity Supply. Connections to the electric supply shall conform to 80.25(A) through (E).

(A) Authorization. Except where work is done under an annual permit and except as otherwise provided in 80.25, it shall be unlawful for any person, firm, or corporation to make connection to a supply of electricity or to supply electricity to any electric equipment installation for which a permit is required or that has been disconnected or ordered to be disconnected.

(B) Special Consideration. By special permission of the authority having jurisdiction, temporary power shall be permitted to be supplied to the premises for specific needs of the construction project. The Board shall determine what needs are permitted under this provision.

(C) Notification. If, within _____ business days after the Electrical Inspector is notified of the completion of an installation of electric equipment, other than a temporary approval installation, the Electrical Inspector has neither authorized connection nor disapproved the installation, the supplier of electricity is authorized to make connections and supply electricity to such installation.

(D) Other Territories. If an installation or electric equipment is located in any territory where an Electrical Inspector has not been authorized or is not required to make inspections, the supplier of electricity is authorized to make connections and supply electricity to such installations.

(E) Disconnection. Where a connection is made to an installation that has not been inspected, as outlined in the preceding paragraphs of this section, the supplier of electricity shall immediately report such connection to the Chief Electrical Inspector. If, upon subsequent inspection, it is found that the installation is not in conformity with the provisions of Article 80, the Chief Electrical Inspector shall notify the person, firm, or corporation making the installation to rectify the defects and, if such work is not completed within fifteen (15) business days or a longer period as may be specified by the Board, the Board shall have the authority

to cause the disconnection of that portion of the installation that is not in conformity.

80.27 Inspector's Qualifications.

(A) Certificate. All electrical inspectors shall be certified by a nationally recognized inspector certification program accepted by the Board. The certification program shall specifically qualify the inspector in electrical inspections. No person shall be employed as an Electrical Inspector unless that person is the holder of an Electrical Inspector's certificate of qualification issued by the Board, except that any person who on the date on which this law went into effect was serving as a legally appointed Electrical Inspector of _____ shall, upon application and payment of the prescribed fee and without examination, be issued a special certificate permitting him or her to continue to serve as an Electrical Inspector in the same territory.

(B) Experience. Electrical inspector applicants shall demonstrate the following:

- (1) Have a demonstrated knowledge of the standard materials and methods used in the installation of electric equipment
- (2) Be well versed in the approved methods of construction for safety to persons and property
- (3) Be well versed in the statutes of _____ relating to electrical work and the *National Electrical Code*, as approved by the American National Standards Institute
- (4) Have had at least _____ years' experience as an Electrical Inspector or _____ years in the installation of electrical equipment. In lieu of such experience, the applicant shall be a graduate in electrical engineering or of a similar curriculum of a college or university considered by the Board as having suitable

requirements for graduation and shall have had two years' practical electrical experience.

(C) Recertification. Electrical inspectors shall be recertified as established by provisions of the applicable certification program.

(D) Revocation and Suspension of Authority. The Board shall have the authority to revoke an inspector's authority to conduct inspections within a jurisdiction.

80.29 Liability for Damages. Article 80 shall not be construed to affect the responsibility or liability of any party owning, designing, operating, controlling, or installing any electric equipment for damages to persons or property caused by a defect therein, nor shall the _____ or any of its employees be held as assuming any such liability by reason of the inspection, reinspection, or other examination authorized.

80.31 Validity. If any section, subsection, sentence, clause, or phrase of Article 80 is for any reason held to be unconstitutional, such decision shall not affect the validity of the remaining portions of Article 80.

80.33 Repeal of Conflicting Acts. All acts or parts of acts in conflict with the provisions of Article 80 are hereby repealed.

80.35 Effective Date. Article 80 shall take effect _____ (_____) days after its passage and publication.

Throughout this document the term "this Code" refers to the compilation of requirements for electrical installations in one- and two-family dwelling units contained therein that have been extracted from NFPA 70-2005, National Electrical Code® (NEC®).

Index

© 2005 National Fire Protection Association. All Rights Reserved.

The copyright in this index is separate and distinct from the copyright in the document that it indexes. The licensing provisions set forth for the document are not applicable to this index. This index may not be reproduced in whole or in part by any means without the express written permission of NFPA.

-A-

- AC and DC conductors in same enclosure**, 300.3(C)(1)
- AC armored cable.** *see* Armored cable (Type AC)
- AC systems**
- Conductor to be grounded, 250.26
 - Grounding connections, 250.24(A)
 - Grounding electrode conductor, 250.66
 - Grounding of, 250.20, 250.30
 - In same metallic enclosures, 300.20
- Access and working space.** *see also* Working space
- Not over 600 volts, 110.26
- Accessible**
- Air-conditioning and refrigeration disconnects, 440.14
 - Conduit bodies, junction, pull, and outlet boxes, 314.29
 - Definition, Art. 100-I
 - Grounding electrode connection, 250.68(A)
 - Overcurrent devices, 240.24
 - Services, 230.70
- AC-DC general-use snap switches**
- Panelboards, use in, 408.36(C)
 - Ratings, type loads, 404.14
- Administration and enforcement**, Annex G
- Adoption of *Code*, Annex G 80.5
 - Application of *Code*, Annex G 80.9
 - Authority, Annex G 80.13
 - Connection to electricity supply, Annex G 80.25
 - Definitions, Annex G 80.2
 - Effective date, Annex G 80.35
 - Electrical board, Annex G 80.15
 - Inspector's qualifications, Annex G 80.27
 - Liability for damages, Annex G 80.29
 - Notice of violations, penalties, Annex G 80.23
 - Occupancy of building or structure, Annex G 80.11
 - Permits and approvals, Annex G 80.19
 - Plans review, Annex G 80.21
 - Records and reports, Annex G 80.17
 - Repeal of conflicting acts, Annex G 80.33
 - Title of *Code*, Annex G 80.7
 - Validity of article, Annex G 80.31
- Aerial cables**
- Installation, 820.44
- Network-powered broadband communications systems-
aerial cables, 830.44
- Air conditioners, room**, 440-VII
- Branch-circuit requirements, 440.62
 - Definition, 440.60
 - Disconnecting means, 440.63
 - Grounding, 440.61
- Air conditioning and refrigerating equipment**,
- Art. 440
 - Branch circuit
 - Conductors, 440-IV
 - Ampacity, determination of, 440.6
 - General, 440.31
 - Multimotor equipment for, 440.35
 - Several motor-compressors for, 440.33
 - Single motor-compressor for, 440.32
 - Outlets, 210.63
 - Selection current, 440-I
 - Definition, 440.2
 - Short-circuit and ground-fault protection, 440-III
 - Equipment for, 440.22(B):
 - General, 440.21; Individual motor- compressor for, 440.22(A)
 - Controllers for, 440-V
 - Rating, 440.41
 - Definition of hermetic refrigerant motor-compressor, 440.2
 - Definitions, 440.2
 - Disconnecting means, 440-II
 - Cord-connected as, 440.13
 - Ratings and interrupting capacity, 440.12
 - Leakage current detection and interruption (LCDI) protection, 440.65
 - Overload protection, 440-VI
 - Application and selection of, 440.52
 - Branch-circuit conductors for, 440.52(B)
 - General, 440.51
 - Motor-compressors for, 440.52(A)
 - On 15- or 20-ampere branch circuits, 440.54
 - Room air conditioners. *see* Air conditioners, room
 - Single machine, when considered, 440.8
- Air plenums.** *see* Plenums

Alarms

Burglar. *see* Remote-control, signaling, and power-limited circuits

Fire, 230.82(5), 230.94 Ex. 4. *see also* Fire alarm systems

Alternators. *see* Generators

Aluminum conduit. *see* Rigid metal conduit

Ambient temperature, 310.10 FPN. *see also* Temperature limitations

Ampacities

Conductors, 310.15, Table 310.16

Definition, Art. 100-I

Grounding, 250.122

Table, 0–2000 volts, 310.16

Antenna systems, radio and television. *see* Community antenna television and radio distribution (CATV) systems; Radio and television equipment

Appliances, Art. 422.

Branch circuits. *see* Branch circuits, appliances

Branch circuits for (utilization equipment), 210.23

Branch-circuit calculations, 220.3

Cords. *see* Cords, flexible

Definition, Art. 100-I

Disconnecting means, 422-III

Dwelling units, outlets, 210.52

Feeder calculations for, 220.40

Grounding, 250-VI

Household cooking, demand loads for, Table 220.55

Installation, 422-II

Load calculations, 220.14, 220.40, Table 220.55

Marking, 422-V

Motor-driven, load, 220.18(A)

Overcurrent protection, 422.11

Single, 210.20, 422.11(E)

Terminals, identification, 200.10(E)

Approval, approved

Definition, Art. 100-I

Equipment and materials, 90.4, 90.7, 110.2, Annex G 80.19

Arc-fault circuit interrupters, 210.12

Definition, 210.12(A)

Protection, 210.12(B)

Arcing parts, 240.41

Enclosure of, 110.18

Armored cable (Type AC), Art. 320

Accessible attics, 320.23

Ampacity, 320.80

Bends, 320.24

Boxes and fittings, 320.40

Definition, 320.2

Exposed work, 320.15

Supports, 320.30

Through or parallel to framing members, 320.17

Uses not permitted, 320.12

Uses permitted, 320.10

Arresters, surge. *see* Lightning (surge) arresters

Attachment plugs (caps)

Construction of, 406.6

Definition, 210.50(B), Art. 100-I

Flexible cords on, 400.7(B)

Grounding type, 406.9

Polarized

Terminal identification, 200.10(B)

Attics

Armored cable, 320.23

Metal clad cable, 330.23

Nonmetallic-sheathed cable, 334.23

Audio equipment, underwater, 680.27(A), 680.43(G)

Authority having jurisdiction, 90.4. *see also* Approval

Automatic

Definition, Art. 100-I

-B-

Back fed devices, 408.86(F)

Backfill, 300.5(F)

Ballasts, electric discharge lamps, 410-XIII, 410-XIV

Protection in fluorescent fixtures, 410.73(E)

Protection in recessed HID fixtures, 410.73(F)

Bare conductors

Definition, Art. 100-I

Service entrance, Type SE, USE, 338.100

Sizing conduits for, Chap. 9, Note 3 to Table 1

Underground conduits, grounded neutral, 230.30 Ex., 230.41 Ex.

Basements (cellars)

Armored cable, 320.15

Lighting outlets required, 210.70(A)(3)

Nonmetallic sheathed cable, 334.15

Receptacles in, 210.8(A)(5), 210.52(G), 406.8(A)

Unfinished, 210.8(A)(5)

Bathroom

Branch circuits for, 210.11(C)(3)

Definition, Art. 100-I

Receptacles in, 210.8(A)(1), 406.8(C)

Bathtubs

Hydromassage, 680-VII

Definition, 680.2

Luminaires (lighting fixtures), 410.4(D)

Bedrooms

Arc-fault circuit-interrupter protection, 210.12(B)

- Bell circuits.** *see* Remote-control, signaling, and power-limited circuits
- Bends,** *see* Chapter 3; wiring system involved
- Bodies, conduit.** *see* Conduit bodies
- Bonding,** 250-V
- CATV and radio distribution systems, 820.100(B)
 - Definition, Art. 100-I
 - Grounding-type receptacles, 250.146
 - Network-powered broadband communications systems, 830.100(D), 830.106(B)
 - Other enclosures, 250.96
 - Outside raceway, 250.102(E)
 - Piping systems and exposed structural steel, 250.104
 - Receptacles, 250.146
 - Service equipment, 250.92, 250.94
 - Swimming pools. *see* Swimming pools
- Bonding jumpers.** *see* Jumpers, bonding
- Bored holes through studs, joists,** 300.4(A)(1)
- Boxes (outlet, device, pull, and junction),** Art. 314.
- Accessibility, 314.29
 - Concealed work, 314.20
 - Conductors, number in box, 314.16
 - Entering boxes, conduit bodies or fittings, 314.17
 - Covers, 314.25, 314.28(C)
 - Cutout. *see* Cabinets, cutout boxes, and meter socket enclosures
 - Damp locations, 314.15
 - Depth, 314.24
 - Exposed surface extensions, 314.22
 - Fill calculations, 314.16(B)
 - Floor, for receptacles, 314.27(C)
 - Grounding, 250.148, 250-VI
 - Insulating. *see* Boxes, nonmetallic
 - Junction, pull. *see* Junction boxes
 - Lighting (luminaire) outlets. *see* Lighting outlets
 - Metal
 - Grounding, 314.4
 - Installation, 314.II
 - Nonmetallic, 314.3, 314.17(C)
 - Repairing plaster around, 314.21
 - Required location, 300.15
 - Round, 314.2
 - Secured supports, 300.11, 314.23
 - Unused openings, closed, 110.12(A)
 - Volume calculations, 314.16(A)
 - Wall or ceiling, 314.20
 - Wet locations, 314.15(A)
- Branch circuits,** Art. 210, Art. 220
- Air conditioners, 440-IV, 440-VII
 - Appliances, 210.23, 422-II
 - Definition, Art. 100-I
 - Arc-fault circuit-interrupter protection, 210.12
 - Calculation of loads, 220-II, Annex D
 - Color code, 210.5
 - Common area, 210.25
 - Conductors, minimum ampacity and size, 210.19
 - Definition, Art. 100-I
 - Fixed electric space heating equipment, 424.3
 - General, 210-I
 - General purpose
 - Definition, Art. 100-I
 - Individual
 - Definition, Art. 100-I
 - Overcurrent protection, 210.20
 - Permissible loads, 210.23
 - Maximum loads, 220.18
 - Multiwire, 210.4
 - Definition, Art. 100-I
 - Outside. *see* Outside branch circuits and feeders *Overcurrent protection, 210.20, 240.3*
 - Permissible loads, 210.23
 - Ratings, 210.3, 210-II
 - Requirements for, Table 210.24
 - Selection current
 - Definition, 440.2
 - Small appliance, 210.11(C)(1)
 - Taps from, 210.19(A), Table 210.24, 240.4(E)
 - Through luminaires (fixtures), 410.11, 410.31
 - Two or more outlets on, 210.24
 - Voltage drop, 210.19(A) FPN No. 4
 - Voltage limitations, 210.6
- Branch-circuit selection current**
- Definition, 440.2
- Building wire.** *see* Conductors
- Definition, Art. 100-I
 - First floor of, 362.10
- Burglar alarm systems.** *see* Remote-control, signaling, and power-limited circuits
- Bushings**
- Fiber. *see* Fiber bushings
 - Insulated, 300.4(F), 312.6(C)
 - Securing fittings or raceways, 300.4(F)
 - Intermediate metal conduit, 342.46
 - Outlet boxes, conduit bodies, and outlet fittings, 314.17(D)
 - Rigid metal conduit, 344.46
 - Rigid nonmetallic conduit, 352.46
 - Underground installations, 300.5(H)
 - Use in lieu of box or terminal fitting, 300.16(B)

-C-**Cabinets, cutout boxes, and meter socket enclosures**, Art. 312

- Construction specifications, 312-II
- Damp, wet, or hazardous (classified) locations, 312.2
- Definitions, Art. 100-I
- Deflection of conductors, 312.6
- Installation, 312-I
- Insulation at bushings, 300.4(F), 312.6(C)
- Position in walls, 312.3
- Switch enclosures, splices, taps, 312.8
- Unused openings, 110.12(A)
- Wire bending space at terminals, 312.6(B)

Cable bending. *see* type of cable**Cable end fittings, changing from cable to knob-and-tube**, 300.16(A)**Cable sheath**

- Definition, 800.2

Cables

- Aerial, 820.44, 830.40
- Armored (Type AC). *see* Armored cable (Type AC)
- CATV, Art. 820
- Continuity, 300.12
- Definition, 800.2
- Heating. *see* Heating cables
- Installed in shallow grooves, 300.4(E)
- Metal-clad cable (Type MC). *see* Metal-clad cable (Type MC)
- Nonmetallic-sheathed (Types NM, NMC, and NMS). *see* Nonmetallic-sheathed cable (Types NM, NMC, and NMS)
- Other types of. *see* names of systems
- Point of entrance
 - Definition, 800.2, 820.2, 830.2
- Portable. *see* Cords, flexible
- Protection against physical damage, 300.4
- Secured, 300.11, 314.17(B) and (C)
- Service. *see* Service cables
- Service-entrance (Types SE and USE). *see* Service-entrance cable (Types SE and USE)
- Splices in boxes, 300.15
- Through studs, joists, rafters, 300.4
- Underground, 230-III, 300.5
- Underground feeder and branch circuit Type UF. *see* Underground feeder and branch-circuit cable (Type UF)

Calculations, Annex D. *see also* Loads**Canopies**

- Boxes and fittings, 314.25
- Live parts, exposed, 410.3

Luminaires (lighting) fixtures

- Conductors, space for, 410.10

Cover

- At boxes, 410.12
- Combustible finishes, covering required between canopy and box, 410.13

Caps. *see* Attachment plugs**CATV systems**. *see* Community antenna television and radio distribution (CATV) systems**Ceiling fans**, 680.22(B), 680.43(B)

- Support of, 314.27(D), 422.18

Cellars. *see* Basements**Cinder fill**

- Intermediate or rigid metal conduits and electrical metallic tubing, in or under, 342.10(C), 344.10(C), 358.12(3)
- Rigid nonmetallic conduit, 352.10(C)

Circuit breakers, Art. 240

- Accessibility and grouping, 404.8
- Definition, Art. 100-I
- Disconnection of grounded circuits, 404.2(B)
- Enclosures, 404.3
- General, 110.9, 240-I
- Overcurrent protection, 240-I
- Panelboards, 408-III
- Service overcurrent protection, 230.90, 230.91
- Services, disconnecting means, 230.70
- Switches, use as, 404.11
- Wet locations, in, 404.4

Circuit directory, panelboards, 110.22, 408.4**Circuit-interrupters, ground-fault**. *see* Ground-fault circuit-interrupters**Circuits**

- Branch. *see* Branch circuits
- Burglar alarm. *see* Remote-control, signaling, and power-limited circuits
- Central station. *see* Fire alarm systems
- Communication. *see* Communication circuits
- Fire alarm
 - Definitions, 760.2
- Grounding, Art. 250
- Impedance, 110.10
- Less than 50 volts
 - Class 1, 725-II
 - Grounding, 250.20(A)
- Number of, in enclosures, 90.8(B)
- Power-limited. *see* Remote-control, signaling, and power-limited circuits
- Protectors required, 800.50, 800.90, 800.100, 800.106, 830.90

- Remote-control. *see* Remote control, signaling, and power-limited circuits
- Signal. *see* Remote-control, signaling, and power-limited circuits
- Telegraph. *see* Communication circuits
- Telephone. *see* Communication circuits
- Underground. *see* Communication circuits
- Ungrounded, 210.10, 215.7, 410.48. *see also* Conductors, ungrounded.
- Clamp fill, boxes**, 314.16(B)(2)
- Clamps, ground**, 250.8, 250.10, 250.70
- Class 1, 2, and 3 circuits**. *see* Remote-control, signaling, and power-limited circuits
- Clean surfaces, grounding conductor connections**, 250.12
- Clearances**. *see also* Enclosures; Space
- Community antenna systems, Art. 820
- Conductors
- Open, outside branch circuits and feeders, 225.18, 225.19
 - Service drop, 230-II
- Lighting luminaires (fixtures), 410.66, 410.76
- Network-powered broadband communications systems, 830.44
- Swimming pools, 680.8
- Clothes closets**
- Heating, 424.38(C)
 - Luminaires (lighting fixtures), 410.8
 - Overcurrent devices, 240.24(D)
- Clothes dryers**
- Calculations for, 220.53
 - Feeder demand factors, Table 220.53
 - Grounding, 250.114(3), 250.140
- CO/ALR**
- Receptacles, 406.2(C)
 - Switches, 404.14(C)
- Color code**
- Branch circuits, 210.5
 - Conductors, 310.12
 - Grounded conductor, 200.6
 - Grounding conductor, 250.119, 310.12(B)
 - Heating cables, 424.35
- Common grounding electrode**. *see* Electrodes, grounding, common
- Common neutral**
- Outside wiring, 225.7(B)
- Communications circuits**, Art. 800
- Access to electrical equipment, 800.21
 - Bonding, 800.100(D), 800.106(B)
 - Cable marking, 800.113
 - Cable substitution, 800.154(G)
- Conductors
- Other circuits with, 800.154(E)
 - Overhead, 800.44
 - Within buildings, 800-V
- Definitions, 800.2
- Grounding, 800.93, 800-IV
- Installation, 800.113, 800.133
- Listing of communications wires and cables, 800.113, 800.179
- Listing of equipment, 800.18, 800-VI
- Marking, 800.113
- Mechanical execution of work, 800.24
- Mobile homes, 800.106
- Protection, 800-III
- Devices, 800.90
 - Grounding, 800.100, 800.106(A)
- Community antenna television and radio distribution (CATV) systems**, Art. 820
- Access to electrical equipment, 820.21
- Cables
- Aerial entrance, 820.44
 - Within buildings, 820-V
 - Entering buildings, 820.47
 - Listing and marking, 820.113, 820.154, 820-VI
 - Outside, 820.44
 - Underground, 820.47
- Definitions, 820.2
- Energy limitations, 820.15
- Grounding, 820-IV
- Cables, 820.93, 820-IV
 - Equipment, 820.103
- Installation of cables and equipment, 820.113, 820.133
- Locations, 820.3
- Mechanical execution of work, 820.24
- Mobile homes, 820.106
- Protection, 820.100(A)(6), 820-III
- Compressors, refrigeration**, Art. 440
- Concealed**
- Definition, Art. 100-I
- Concentric knockouts**. *see* Knockouts
- Concrete**
- Electrodes encased in, 250.50 Ex., 250.52(A)(2)(1) and (A)(3), 250.66(B), 250.68(A) Ex. 1
 - Metal raceways and equipment in, 300.6(B)
- Conductor fill**
- Boxes, 314.16(B)(1) and (5)
 - Electrical metallic tubing, 358.22
 - Electrical nonmetallic tubing, 362.22
 - Flexible metal conduit, 348.22, Table 348.22
 - General installations, 300.17

- Intermediate metal conduit, 342.22
- Liquidtight flexible metal conduit, 350.22
- Liquidtight flexible nonmetallic conduit, 356.22
- Maximum permitted, 300.17
- Outlet boxes, etc., 314.16
- Rigid metal conduit, 344.22
- Rigid nonmetallic conduit, 352.22
- Conductors.** *see also* Cords, flexible; Fixture wires
 - Aluminum, conductor material, 310.14
 - Aluminum, properties of, Chap. 9, Table 8
 - Ampacities of, 310.15, Table 310.16
 - Armored cable, Type AC. *see* Armored cable (Type AC)
 - Bare. *see* Bare conductors
 - Boxes and fittings, junction, 314.16, 314.17
 - Branch circuits, Art. 210
 - Buried, 310.7
 - Cabinets and cutout boxes, 312.5 through 312.7
 - Cablebus. *see* Cablebus
 - Calculations, examples, Annex D
 - Circuit
 - Communications, Art. 800
 - Fire alarm, Art. 760
 - Signal, remote-control, power-limited, Art. 725
 - Combinations, Chap. 9, Table 1
 - Communications circuits, 800-II, 800-V
 - Conduit or tubing, number in, 342.22, 344.22, 348.22, 350.22, 352.22, 356.22, 358.22, 362.22, Annex C, Chap. 9 Tables, Table 348.22
 - Cooling of electric equipment, 110.13(B)
 - Copper, 110.5
 - Ampacities, Table 310.16
 - Properties, Chap. 9, Table 8
 - Copper-clad aluminum
 - Definition, Art. 100-I
 - Cords, flexible. *see* Cords, flexible
 - Corrosive conditions. *see* Corrosive conditions
 - Covered
 - Definition, Art. 100-I
 - Deflection of. *see* Deflection of conductors
 - Different systems, 300.3(C)
 - Dimensions of, Chap. 9, Table 4
 - Electrical metallic tubing. *see* Electrical metallic tubing
 - Electrical nonmetallic tubing. *see* Electrical nonmetallic tubing
 - Enclosure, grounding, 250-IV
 - Equipment grounding. *see* Equipment grounding conductors
 - Feeder, Art. 215
 - Fire alarm systems, 760.52
 - Gauges (AWG), general provisions, 110.6
 - General wiring, Art. 310
 - Grounded
 - Alternating current systems, 250.24, 250.26
 - Identification, 200.6, 200.7, 210.5(A)
 - Change in size, 240.23
 - Definition, Art. 100-I
 - Different systems, 200.6(D)
 - Overcurrent protection, 240.22
 - Services
 - Disconnection of, 230.70, 230.75
 - Overcurrent protection, 230.90(B)
 - Switches, disconnection, 404.2(B)
 - Use and identification, Art. 200
 - Grounding. *see* Grounding conductors
 - Grounding electrode. *see* Grounding electrode conductors
 - Identification, 310.12
 - Insulated
 - Definition, Art. 100-I
 - Insulating materials, 310.13
 - Insulation, Art. 310
 - Insulation at bushings, No. 4 and larger, 300.4(F), 312.6(C)
 - Length in boxes, 300.14
 - Length in transient voltage surge suppressors, 285.12
 - Lightning rods, spacing from, 250.106
 - Liquidtight flexible metal conduit. *see* Liquidtight flexible metal conduit
 - Liquidtight flexible nonmetallic conduit. *see* Liquidtight flexible nonmetallic conduit
 - Metal enclosures, spacing from lightning rods, 250.106
 - Metal-clad cable. *see* Metal-clad cable
 - Minimum size, 230.42, 310.5
 - Multioutlet assembly. *see* Multioutlet assembly
 - Multiple, 250.102(C), 250.122(F), 300.20, 310.4
 - Nonmetallic sheathed cable, Types NM, NMC, and NMS. *see* Nonmetallic-sheathed cable (Types NM, NMC, and NMS)
 - Number of, in. *see* Conductor fill
 - Outlet boxes, temperature limits, 410.11
 - Outside wiring, Art. 225
 - Overcurrent protection, 240.3, 240.4
 - Overhead, 800.44
 - Paralleled, 250.102(C), 250.122(F), 300.20, 310.4
 - Properties of, Chap. 9, Table 8
 - Raceways, number of conductors in. *see* Conductor fill
 - Radio and television
 - Antenna distribution systems, Art. 820
 - Remote-control circuits, Art. 725
 - Rigid metal conduit. *see* Rigid metal conduit
 - Same circuit, 300.5(I)

- Selection of, examples, Annex D
- Service. *see* Service cables; Service-entrance cable (Types SE and USE); Service-entrance conductors
 - Definition, Art. 100-I
- Service-entrance. *see* Service entrance conductors
- Signal circuits, Art. 725, Art. 760
- Sizes, 110.6, Chap. 9, Tables 5 and 5A. *see also* Conductors, minimum size
- Stranded, 310.3
- Temperature, limitations of, 310.10, 338.10(B)(3)
- Underground feeder and branch-circuit cable. *see* Underground feeder and branch-circuit cable (Type UF)
- Ungrounded
 - Identification, 210.5(C)
 - Services, 230.90(A)
 - Wet locations, 225.4, 310.8(C)
- Conduit bodies.** *see also* Boxes, outlet, device, pull, and junction
 - Definition, Art. 100-I
 - Number of conductors, 314.16(C)
 - Pull and junction box, 314.28
 - Short radius, 314.5
 - Support of, by rigid nonmetallic conduit, 352.10(H)
- Conduit fill.** *see also* Conductor fill
 - Equipment grounding conductors, Chap. 9, Note 3 to Table 1
 - Grounding conductor, 310.15(B)(5)
- Conduit nipples,** Chap. 9, Note 4 to Table 1
- Conduits**
 - Boxes supporting, 314.23(H)(2)
 - Circuits, physical protection of remote control, 725.11(B)
 - Conductors, number in, Chap. 9, Table 1 and Annex C, Tables C1 through C10(A)
 - Dimensions, Chap. 9, Table 4
 - Electrical metallic tubing. *see* Electrical metallic tubing
 - Electrical nonmetallic tubing. *see* Electrical nonmetallic tubing
 - Flexible metal. *see* Flexible metal conduit
 - Intermediate metal. *see* Intermediate metal conduit
 - Liquidtight flexible metal. *see* Liquidtight flexible metal conduit
 - Liquidtight flexible nonmetallic. *see* Liquidtight flexible nonmetallic conduit
 - Metallic, grounding runs 7.5 m (25 ft), 250.86 Ex.1
 - Outside wiring, 225.10
 - Rigid metal. *see* Rigid metal conduit
 - Rigid nonmetallic. *see* Rigid nonmetallic conduit
- Connections**
 - Aluminum, copper conductors, 110.14
 - Feed-through. *see* Feed-through connections of neutral conductors
 - Grounding conductor, 250-III, 250-VI
 - Integrity of, 110.12(C)
 - Splices, 110.14(B)
 - Switches, 404.2
 - Temperature limitations, 110.14(C)
 - Terminals, general provisions, 110.14(A)
- Connectors**
 - Armored cable, 320.40
 - Boxes, 314.17
 - Cabinets and cutout boxes, 312.5(C)
 - Electrical metallic tubing, 358.42
 - Flexible metal conduit, 348.42
 - Intermediate metal conduit, 342.42
 - Liquidtight flexible metal conduit, 350.42
 - Liquidtight flexible nonmetallic conduit, 356.42
 - Pressure (solderless)
 - Definition, Art. 100-I
 - Rigid metal conduit, 344.42
- Construction sites**
 - Assured equipment grounding conductor program, 590.6(B)(2)
 - Extension cord sets, 590.6(A) and (B)(2)
 - Ground-fault circuit-interrupter, protection for, 590.6(A) and (B)(1)
- Continuity**
 - Electrical, metal raceways and cables, 250.96, 250.97
 - Service equipment, 250.92, 250.94
 - Equipment grounding conductors, 250.124
 - Grounding, metal boxes, grounding-type receptacles, 250.146, 250.148
 - Mechanical, raceways and cables, 300.10, 300.12
 - Conductors, 300.13
 - Grounded conductor of multi-wire circuits, 300.13(B)
- Continuous duty**
 - Definition, Art. 100-I
- Continuous load**
 - Applications, 210.19(A), 210.20(A), 215.2(A)
 - Definition, Art. 100-I
- Control**
 - Remote
 - Circuits. *see* Remote-control, signaling, and power-limited circuits
- Convenience outlets.** *see* Receptacles
- Cooking unit, counter-mounted.** *see also* Ranges; Ovens, wall-mounted
 - Branch circuits, 210.19(A)(3), Note 4 to Table 220.55
 - Definition, Art. 100-I
- Cooling of equipment,** 110.13(B)

- Copper conductors.** *see* Conductors, copper
- Copper-clad aluminum conductors.** *see* Conductors, copper-clad aluminum
- Cord sets.** *see* Extension cord sets
- Cords**
- Flexible, Art. 400, 422.16
 - Identified conductors within, 200.6(C)
 - Lampholders, insulating bushings, 410.30(A)
 - Pull at joints and terminals, 400.10
 - Repair of, hard service, 400.9
 - Splices and taps, 400.9
 - Construction sites, 590.4(G)
 - Swimming pools, fountains, and similar installations, 680.7, 680.21(A)(5), 680.23(B)(3), 680.42(A)
 - Uses not permitted, 400.8
 - Uses permitted, 400.7
- Correction factors, ambient temperature,** Table 310.16
- Corrosion protection.** *see* Protection, corrosion
- Corrosive conditions**
- Conductors and conductor insulation, 300.6, 310.9
 - Deteriorating agents, 110.11
- Countertops, outlets,** 210.52, 406.4(E)
- Couplings**
- Electrical metallic tubing, 358.42
 - Intermediate metal conduit, 342.42
 - Rigid metal conduit, 344.42
 - Rigid nonmetallic conduit, expansion fittings, 352.44
 - Running threads at, 342.42(B), 344.42(B)
 - Threaded and threadless, 250.92(B)
- Cove lighting, space for,** 410.9
- Covers**
- Boxes and fittings, 314.25, 314.28(C)
 - Faceplates. *see* Faceplates
 - Pool cover, electrically operated, 680.27(B)
 - Definition, 680.2
- Cross sectional areas**
- Conductors, Chap. 9, Tables 5 through 8
 - Conduits, Chap. 9, Table 4
- Current-carrying capacities.** *see* Ampacities
- Cutout boxes.** *see also* Cabinets, cutout boxes, and meter socket enclosures
- Definition, Art. 100-I
- D-**
- Damp or wet locations,** 110.11. *see also* Wet locations
- Boxes and fittings, 314.15(A)
 - Cabinets and cutout boxes, 312.2(A)
 - Definition, Art. 100-I
 - Lampholders, 410.49
 - Luminaires (lighting fixtures), 410.4(A)
 - Overcurrent protection, enclosure, 240.32
 - Panelboards, 408.37
 - Receptacles, 406.8
- Dead front**
- Definition, Art. 100-I
- Definitions,** Art. 100
- Deflection of conductors**
- Cabinets and cutout boxes, 312.6
- Demand factor.** *see also* Loads
- Definition, Art. 100-I
- Deteriorating agents,** 110.11
- Device.** *see also* Switches; Receptacles
- Definition, Art. 100-I
- Device or equipment fill for boxes,** 314.16(B)(4)
- Diagrams**
- Feeders, 215.5
 - Luminaires, closet storage space, Fig. 410.8
 - Services, Fig. 230.1
 - Swimming pools, clearance from pool structures, Fig. 680.8
- Different systems, conductors in same enclosure,** 300.3(C), 725.55(B), 760.55, 800.133(A), 820.133 (A)
- Dimensions**
- Conductors, Chap. 9, Tables 5 through 8
 - Conduits and tubing, Chap. 9, Table 4
- Direct burial**
- Liquidtight flexible metal conduit, 350.10(3)
 - Liquidtight flexible nonmetallic conduit, 352.10(G)
 - Rigid nonmetallic conduit, Table 300.5, 352.10(G)
 - Underground feeder and branch-circuit cable, 340.10(1)
 - Underground service cable, 230.49, Table 300.5, 310.7
- Disconnecting means**
- Air-conditioning and refrigerating equipment, 440-II
 - Appliances, 422-III
 - Definitions, Art. 100-I
 - Electric space heating equipment, 424-III
 - Identification, 110.22, 230.70(B)
 - Pools, spas, and hot tubs, 680.12
 - Separate building on same premises, 250.32(D)
 - Services, 230-VI
 - Connections, ahead of, 230.82
- Dissimilar metals.** *see* Metals, dissimilar
- Double insulated, appliances and tools,** 250.114 Ex., 422.16(B)(1) Ex., 422.16(B)(2) Ex.
- Double locknuts.** *see* Locknuts, double, required
- Drainage**
- Raceways. *see* Raceways, drainage

Drip loops

- Conductors entering buildings, 225.11, 230.24(B)(1), 230.52, 230.54(F)
- Service heads, 230.54(F)

Driveways

- Clearance of conductors, 225.18
- Clearance of service drop, 230.24(B)

Drop. *see* Service drops; Voltage and volts, drop**Dry location**, 110.11. *see also* Damp or wet locations

- Definition, Art. 100-I

Dryers, clothes. *see* Clothes dryers**Duct heaters, installation of**, 424-VI**Ducts**

- Wiring in, 300.21, 300.22, 725.3(C), 760.3(B), 800.133(D), 800.154(A), 820.113, 820.154(A), 830.154(B)

Duty, types

- Definitions, Art. 100-I

Dwellings. *see also* Appliances; Boxes; Branch circuits; Fixtures; Grounding, and similar general categories; Luminaires (lighting fixtures)

- Branch-circuit voltages, 210.6(A)
- Definitions, Art. 100-I
- Feeder load, calculations for, 220.14(J), 220.82 through 220.85, Annex D
- Lighting loads for, Table 220.12
- Luminaires (lighting fixtures), 410.75, 410.80(B)
- Panelboards as services, 408.3(C), 408.36(A)(2) Ex. 2
- Receptacle circuits required, 210.11
- Receptacle outlets required, 210.52, 680.22(A)
 - Protection by ground-fault circuit- interrupters, 210.8(A), 680.22(A)(5)

-E-**Eccentric knockouts.** *see* Knockouts**Elbows, metal, protection from corrosion**, 300.6**Electrically operated pool covers.** *see* Covers, pool, electrically operated**Electrical metallic tubing (Type EMT)**, Art. 358

- Bends, 358.24, 358.26
- Connectors and couplings, 358.42
- Definition, 358.2
- Grounding, 358.60
- Installation, 358-II
- Listing, 358.6
- Maximum number of conductors and fixture wires in, Tables C1 and C1A
- Number of conductors in, 358.22
- Reaming and threading, 358.28

Securing and supporting, 358.30

Size, 358.20

Splices and taps, 358.56

Uses not permitted, 358.12

Uses permitted, 358.10

Wet locations, in, 358.10(C)

Grounding, 250.96(B), 250.146(D)

Panelboards, 408.20 Ex.

Receptacles, 406.2(D)

Electrical nonmetallic tubing (Type ENT), Art. 362

Bends, 362.24, 362.26

Bushings, 362.46

Definition, 362.2

Grounding, 362.60

Installation, 362-II

Joints, 362.48

Listing, 362.6

Maximum number of conductors and fixture wires in, Tables C2 and C2A

Number of conductors in, 362.22

Securing and supporting, 362.30

Size, 362.20

Splices and taps, 362.56

Through metal framing members, 300.4(B)

Trimming, 362.28

Uses not permitted, 362.12

Uses permitted, 362.10

Electric discharge lighting

Connection to luminaires (lighting fixtures), 410.14, 410.30(C)

More than 1000 volts, 410-XIV

1000 volts or less, 410-XIII

Wiring, equipment, 410.73(A), 410-XIV

Electrodes, grounding, 250.64(f). *see also* Grounding electrode conductors

Aluminum, 250.52(B)

Common, 250.58

Concrete encased, 250.50 Ex., 250.52(A)(2)(1) and (A)(3), 250.66(B), 250.68(A) Ex. 1

Definition, Art. 100-I

Gas piping as, 250.52(B)

Made, 250.50, 250.52

Metal frame of building as, 250.52(A)(2)

Metal water piping system, 250.52(A)(1)

Resistance to ground of, 250.56

Enamel, coating of

Electrical metallic tubing, 358.10(B)

General equipment, indoor use only, 300.6(A)

Intermediate metal conduit, 342.10(B)

- Metal boxes, 314.40(A)
 - Metal cabinets, 312.10(A)
 - Removing for grounding connections, 250.96(A)
 - Rigid metal conduit, 344.10(B)
 - Enclosed**
 - Definition, Art. 100-I
 - Enclosures**
 - Arcing parts, 110.18
 - Bonding, 250.96, 250.146
 - Cabinets and cutout boxes, 312.7 through 312.9, 312.11(D)
 - Circuits in, number of, 90.8(B)
 - Definition, Art. 100-I
 - Grounding, 250.64(E), 250-IV
 - High-intensity discharge lamp auxiliary equipment, 410.54(A)
 - Overcurrent protection, 240-III
 - Panelboards, 408.38
 - Switches, 404.3, 404.12
 - Energized**
 - Definition, Art. 100-I
 - Energized parts.** *see also* Live parts
 - Energy-limited, Class 2 and Class 3 control and signal circuits,** 725.41
 - Enforcement of code,** 90.4, Annex G
 - Equipment.** *see also* specific types of
 - Approval, 90.4, 110.2, Annex G 80.19
 - Cooling of, 110.13(B)
 - Definition, Art. 100-I
 - Examination of, 90.7, 110.3
 - Grounding, 250-VI
 - Installation, general provisions, Art. 110
 - Mounting. *see* Mounting of equipment
 - Service
 - Definition, Art. 100-I
 - Equipment grounding conductor fill and boxes,** 314.16(B)(5)
 - Equipment grounding conductors**
 - Connections at outlets, 250.146, 250.148
 - Installation, 215.6, 250.120, 250.130
 - Sizing, 250.122
 - Types recognized, 250.118, 250.120, 250.134
 - Examples (computations),** Annex D
 - Exhaust ducts.** *see* Ducts
 - Expansion joints (fittings),** 250.98, 300.7(B), 352.44, 424.44(C), 424.98(C)
 - Explanatory material FPN,** 90.5(C)
 - Exposed.** *see also* Enclosures
 - Extensions, boxes, and fittings, 314.22
 - Live parts, 110.26
 - Definition, Art. 100-I
 - Structural steel, grounding, 250.52(A)(2)
 - Wiring methods
 - Definition, Art. 100-I
 - Extension cord sets**
 - On construction sites, 590.6(A) and (B)(2)
 - Extensions**
 - Boxes and fittings, exposed, 314.22
 - Externally operable.** *see* Operable, externally
- F-**
- Faceplates**
 - Grounding, 404.9(B), 406.5(B)
 - Material, 404.9(C), 406.5
 - Minimum thicknesses for, 404.9(C), 406.5
 - Mounting surfaces, against, 404.9(A), 404.10(B), 406.4, 406.8(E)
 - Fans, ceiling.** *see* Ceiling fans
 - Feeder assembly, mobile homes**
 - Definitions, 550.2
 - Feeders, Art. 215, Art. 220**
 - Calculation of loads, 215.2(A), 220.40, 220-IV, Annex D
 - Definition, Art. 100-I
 - Ground-fault circuit-interrupters, with, 215.9
 - Grounding means, 215.6
 - Identification, 225.37
 - Loads. *see* Loads, feeder
 - Mobile homes and parks, 550-III
 - Outside. *see* Outside branch circuits and feeders
 - Services, 220-II
 - Ferrous metals, protection from corrosion,** 300.6(A)
 - Festoon lighting**
 - Conductor size, 225.6(B)
 - Definition, Art. 100-I
 - Fiber bushings, AC cable ends,** 320.40
 - Figures.** *see* Diagrams
 - Fine Print Notes FPN, mandatory rules, permissive rules, and explanatory material,** 90.5
 - Finish rating**
 - Definition, 362.10 FPN 2
 - Fire alarms.** *see* Alarm systems, health care facilities; Alarms; Fire alarm systems
 - Fire alarm systems, Art. 760**
 - Access to electrical equipment, 760.7
 - Circuits extending beyond one building, 760.11
 - Classification, 760.15
 - Connections at services, 230.82(5), 230.94 Ex. 4
 - Definitions, 760.2
 - Grounding, 250.112(I), 760.9

- Identification, 760.10
- Installation, 760.11
- Location, 760.3
- Mechanical execution of work, 760.8
- Nonpower-limited circuits, 760-II
 - Listing, 760.81
 - Marking, 760.81
 - Power source requirements, 760.21
 - Requirements, 760.15
 - Wiring method, 760.25
- Power-limited circuits, 760-III
 - Cable substitutions, 760.61(D), Table 760.61
 - Conductor separation, 760.55
 - Conductor size, 760.57
 - Conductor support, 760.58
 - Installation, 760.56
 - Location of overcurrent devices, Chap. 9, Tables 12(A) and 12(B)
 - Overcurrent protection, Chap. 9, Tables 12(A) and 12(B)
 - Power sources, 760.41
 - Wiring methods and materials
 - Load side, 760.52
- Fire spread**
 - Prevention of, wiring methods, 300.21, 725.3(B), 760.3(A)
- Fire-stopped partitions**, 300.21. *see also* Firewalls
- Firewalls, wiring through**, 300.21
- Fittings**, Art. 314. *see also* Wiring Methods, types and materials
 - Conduit bodies, 314.16
 - Definition, Art. 100-I
 - Expansion, 352.44
 - Insulation, 300.4(F)
- Fixed electric space heating equipment**, Art. 424
 - Branch circuits for, 424.3
 - Cables, 424-V
 - Area restrictions, 424.38
 - Clearances, wiring
 - Ceilings, 424.36
 - Other objects, openings, 424.39
 - Construction, 424.34
 - Finished ceilings, 424.42
 - Installation
 - Cables, 424.44
 - Nonheating leads, 424.43
 - Marking, 424.35
 - Splices, 424.40, 424.41(D)
 - Tests and inspections, 424.45
 - Control and protection, 424-III
 - Controllers, 424.20(A)
 - Disconnecting means, 424.19 through 424.21
 - Indicating, 424.21
 - Overcurrent protection, 424.22
 - Duct heaters, 424-VI
 - Air flow, 424.59
 - Condensation, 424.62
 - Disconnecting means, location, 424.65
 - Elevated inlet temperature, 424.60
 - Fan circuit interlock, 424.63
 - Identification, 424.58
 - Installation, 424.61, 424.66
 - Limit controls, 424.64
 - Installation, 424-II
 - Location
 - Exposed to physical damage, 424.12(A)
 - Wet areas, 424.12(B)
 - Spacing, combustible materials, 424.13
 - Special permission, 424.10
 - Supply conductors, 424.11
 - Marking, 424-IV
 - Heating elements, 424.29
 - Nameplate, 424.28
 - Overcurrent protection for, 424.22
 - Radiant heating panels and heating panel sets, 424-IX
 - Clearances, wiring
 - Ceilings, 424.94
 - Walls, 424.95
 - Connection, 424.96
 - Definitions, 424.91
 - Installation, 424.93, 424.98
 - Markings, 424.92
 - Nonheating leads, 424.97
 - Resistance-type boilers, 424-VII
- Fixed equipment, grounding**, 250.110, 250.112, 250.116, 250.134, 250.136
- Fixtures**. *see* Luminaires (lighting fixtures)
- Flame spread**. *see* Fire spread
- Flashers, time switches, etc.**, 404.5
- Flexible cords**. *see* Cords, flexible
- Flexible metal conduit (Type FMC)**, Art. 348
 - Bends, 348.24 and 348.26
 - Couplings and connectors, 348.42
 - Definition, 348.2
 - Grounding and bonding, 348.60
 - Installation, 348-II
 - Liquidtight. *see* Liquidtight flexible metal conduit
 - Listing, 348.6

- Maximum number of conductors and fixture wires in, Tables C3 and C3A
 - Number of conductors, 348.22
 - Securing and supporting, 348.30
 - Size, 348.20
 - Splices and taps, 348.56
 - Trimming, 348.28
 - Uses not permitted, 348.12
 - Uses permitted, 348.10
 - Floors, receptacles**, 210.52(A)(3), 250.146(C), 314.27(C)
 - Fluorescent luminaires (lighting fixtures)**, 410-XIII, 410-XIV
 - Ballast protection required, 410.73(E)
 - Connection of, 410.14, 410.30(C)
 - Load calculations
 - Ampere ratings, ballasts, 220.18(B)
 - Branch circuits, 210.23
 - Raceways, 410.31
 - Snap switches for, 404.14(A)(1) and (B)(2)
 - Surface-mounted or recessed, 410.8(B)(2), 410.8(D)(2) and (4)
 - Thermal protection, 410.73(E)
 - Formal interpretations**, 90.6
 - Forming shells, underwater pool lighting fixtures**, 680.23(B), 680.24(B), 680.26(B)(2), 680.27(A)(3)
 - Definition, 680.2
 - FPN.** *see* Fine Print Notes, explanatory material
 - Fuel cell systems**, Art. 692
 - Furnaces.** *see* Heating equipment, central
 - Fuseholders**
 - Plug fuses, 240-V
 - Fuses**, Art. 240.
 - Enclosures, 240-III
 - Location in circuit, 240.21
 - Location on premises, 240.24
 - Plug, Edison-base type, 240-V
 - Future expansion and convenience**, 90.8(A)
- G-**
- Gages (AWG), conductors**, 110.6
 - Gas pipe**
 - As grounding electrode, 250.52(B)(1)
 - General provisions, installation of wiring and equipment**, Art. 110
 - General requirements for wiring methods**, Art. 300. *see also* Wiring methods
 - Boxes, conduit bodies, or fittings, where required, 300.15
 - Changing raceway or cable to open wiring, 300.16
 - Conductors, 300.3
 - Different systems, 300.3(C)
 - Installation with other systems, 300.8
 - Insulated fittings, 300.4(F)
 - Number and sizes of, in raceways, 300.17
 - Exhaust and ventilating ducts, wiring, 300.22
 - Free length of wire at outlets, junction and switch points, 300.14
 - Induced currents in metal enclosures, 300.20
 - Mechanical and electrical continuity, conductors, raceways, cables, 300.10, 300.12, 300.13
 - Protection against
 - Corrosion, 300.6
 - Physical damage, 300.4
 - Raceway installations, 300.18
 - Raceways and cables with other systems, 300.8
 - Raceways and fittings, metric designator and trade size, 300.1(C)
 - Raceways as a means of support, 300.11(B)
 - Securing and supporting, 300.11
 - Spread of fire or products of combustion, 300.21
 - Temperature limitations. *see* 310.10
 - Through studs, joists, rafters, 300.4
 - Underground installations, 300.5
 - Voltage limitations, 300.2
 - Wiring in ducts, plenums, airhandling spaces, 300.22
 - Generators**, Art. 445
 - Goosenecks, service cables**, 230.54
 - Grooves, shallow, cables and raceways installed in**, 300.4(E)
 - Ground**
 - Definition, Art. 100-I
 - Voltage to
 - Definition, Art. 100-I
 - Ground clamps**, 250.8, 250.10, 250.70
 - Grounded**
 - Definition, Art. 100-I
 - Effectively
 - CATV system, 820.100, 820-IV
 - Communication system, 800-IV
 - Definition, Art. 100-I
 - Solidly
 - Definition, Art. 100-I
 - Grounded conductor.** *see* Conductors, Grounded; Neutral
 - Ground-fault circuit-interrupters**
 - Accessory buildings, dwelling units, 210.8(A)(2)
 - Basements, dwelling units, unfinished, 210.8(A)(5)
 - Bathtubs, hydromassage, 680.71
 - Definition, Art. 100-I
 - Electrically operated pool covers, 680.27(B)(2)

- Garages, dwelling units, 210.8(A)(2)
 Permitted uses, 210.8, 215.9
 Receptacles, 210.8
 Bathrooms, in dwelling units, 210.8(A)(1)
 Construction sites, at, 590.6
 Existing, 406.3(D)(2)
 Garages, in dwelling units, 210.8(A)(2)
 Kitchens in dwelling units, 210.8(A)(6)
 Outdoors, dwelling units, 210.8(A)(3)
 Pools, 680.5, 680.6, 680.22(A)(5), 680.32
 Required, 210.8
 Spas and hot tubs, 680.43(A), 680.44
 Wet bar, laundry, and utility sinks, 210.8(A)(7)
- Grounding**, Art. 250. *see also* subhead under entries for specific wiring and equipment
 AC systems, 250.20, 250.24, 250.26
 Air-conditioning units, 250.114
 Appliances, 250.114
 Bonding. *see* Bonding
 CATV systems, 820.93, 820-IV
 Circuits, 250-I
 Less than 50 volts, 250.20(A)
 Clothes dryers, 250.114(3), 250.140
 Clothes washers, 250.114
 Communications systems, 800.93, 800-IV
 Continuity, 250.96
 Dishwashers, 250.114
 Electrode system, 250-III
 Enclosures, 250.64(E), 250-IV
 Equipment, cord- and plug-connected, 250.114
 Fire alarm systems, 250.112(I), 760.9
 Fixed equipment, 250.110, 250.112, 250.134
 Fixtures, lampholders, etc., 410.105(B), 410-VI
 Freezers, 250.114
 Metal enclosures for conductors, 250.80, 250.86
 Metal faceplates, 404.9(B), 406.5(B)
 Metal siding, 250.116 FPN
 Methods, 250-VII
 Nonelectrical equipment, 250.116
 Panelboards, 408.40
 Portable equipment, 250.114
 Ranges and similar appliances, 250.140
 Receptacles, 210.7, 250.146, 250.148, 406.3
 Refrigerators, 250.114
 Separate buildings, 250.32
 Spas and tubs, 680.6, 680.7(B), 680.43(F)
 Swimming pools, 680.6, 680.7(B), 680.23(B)(3) and (F)(2), 680.24(D), 680.25(B)
 Switches, 404.12
 Systems, 250-I, 250-II
 Tools, motor operated, 250.114
 Transient voltage surge suppressors, 285.25
- Grounding conductors**, 250-III, 250-VI. *see also* Equipment grounding conductors; Grounding electrode conductors
 Definition, Art. 100-I
 Earth as, 250.4(A)(5), 250.54
 Enclosures, 250-IV
 Identification, multiconductor cable, 250.119
 Installation, 250.64, 250.120
 Material, 250.62
 Objectionable current over, 250.6
 Sizes, 250.122
- Grounding electrode conductors**. *see also* Electrodes, grounding
 Connection to electrodes, 250.24(D), 250-I, 250-III
 Definition, Art. 100-I
 Installation, 250.64
 Material, 250.62, 250.118
 Sizing, 250.66
- Grounding-type attachment plugs**, 406.9
- Ground ring**, 250.50(4)
- Grouping of disconnects**, 230.72
- Guarded**
 Definition, Art. 100-I
- Guarding, guards**. *see also* Enclosures; Live parts
 Construction sites, 590.7
 Live parts
 General, 110.27
- H-**
- Hallways, outlets**, 210.52(H)
- Heating appliances**, Art. 422. *see also* Water heaters
- Heating cables**, Art. 424
- Heating elements**
 Marking, 422.61
- Heating equipment**
 Central, 422.12
- Heating panels and heating panel sets, radiant**. *see* Fixed electric space heating equipment, radiant heating panels and heating panel sets.
- Heavy-duty lampholders**
 Branch circuits, 210.21(A), 210.23, Table 210.24
 Unit loads, 220.3(14)(E)
- Hermetic refrigerant motor compressors**. *see also* Air-conditioning and refrigerating equipment
 Ampacity and rating, 440.6(A)
 Definition, 440.2
 Marking, 440.4
 Rating and interrupting capacity, 440.12(A)

Hoods, range, cord-and-plug connected, 422.16(B)(4)

Hot tubs. *see* Spas and hot tubs

Hydromassage bathtubs, 680-VII

Definition, 680.2

-I-

Identification

Disconnecting means, 110.22

Grounded conductors, Art. 200

Panelboard circuits, 408.30

Service disconnecting means, 230.70(B)

Wiring device terminals, 250.126

Identified

Definition, Art. 100-I

Incandescent lamps, Art. 410.

Snap switches for, 404.14(B)(3)

Independent

Supports, services, over buildings, 230.29

Individual branch circuits. *see* Branch circuits, individual

Induced currents, metal enclosures, 300.20

Inductive loads

Switches, types, ratings, 404.14

Infrared lamp industrial heating appliances,

Branch circuits, 210.23(C), 424.3(A)

In sight from

Air-conditioning or refrigerating equipment, 440.14

Definition, Art. 100-I

Duct heaters, 424.65

Fixed electric space heating equipment, 424.19(A)

Motor driven appliances, 422.32

Room air conditioners, 440.63

Instructions, 110.3(B)

Insulation

Conductors. *see* Conductors, insulation

Double. *see* Double insulated, appliances and tools

Equipment, 110.3(A)(4)

Heating cables, 424-V

Integrity, 110.7

Insulators, nonabsorbent, 230.27

Intermediate metal conduit (Type IMC), Art. 342

Bends, 342.24, 342.26

Bushings, 342.46

Couplings and connectors, 342.42

Definition, 342.2

Dissimilar metals, 342.14

Installation, 342-II

Listing, 342.6

Maximum number of conductors and fixture wires in,

Tables C4 and C4A

Number of conductors, 342.22

Reaming and threading, 342.28

Size, 342.20

Splices and taps, 342.56

Supports and securing, 342.30

Uses permitted, 342.10

Wet locations, 342.10(D)

Intermittent duty

Definition, Art. 100-I

Interpretations, formal. *see* Formal interpretations

Interrupting rating, 110.9

Definition, Art. 100-I

Introduction, Art. 90

Isolated

Arcing parts, 110.18

Definition, Art. 100-I

Equipment grounding conductor, 250.146 FPN

-J-

Joints. *see also* Splices and taps

Expansion. *see* Expansion joints

Grounding electrode conductor, 250.64(C)

Insulating, fixtures, 410.16(E)

Insulation of, 110.14(B)

Strain at, 400.10

Joists

Air-handling, space, 300.22(C) Ex.

Armored cable, 320.23(A)

Electric space heating cables, 424.41(J)

Holes through or notches in, 300.4(A)

Nonmetallic sheathed cable, 334.15(C)

Parallel to framing members, cables and raceways,
300.4(D)

Jumpers, bonding, 250.28, 250.102

Definition, Art. 100-I

Equipment, 250.102

Definition, Art. 100-I

Grounding-type receptacles, 250.146

Main

Definition, Art. 100-I

Piping systems, 250.104

Service equipment, 250.28, 250.92(B), 250.102(C)

Junction boxes. *see also* Boxes; Pull boxes

Accessibility, 314.29

Covers, 314.28(C)

Nonheating cable leads, 424.43

Size

Conductors 4 AWG and larger, 314.16, 314.28(A)

Conductors 6 AWG and smaller, 314.16(C)(1)

Supports, 314.23

- Swimming pools, 680.23(C), 680.24
Switch enclosures, 312.8, 404.3(B)
- K-**
- Knockouts**
Bonding service equipment, 250.92(B)
Openings to be closed, 110.12(A), 314.17(A)
- L-**
- Labeled**
Definition, Art. 100-I
- Lampholders**
Branch circuits supplying, 210.23
Damp or wet locations, 410.4(A), 410.49
Double-pole switched, 410.48
Heavy-duty. *see* Heavy-duty lampholders
Mogul base. *see* Mogul base lampholders
Outdoor, 225.24
Pendant
 Bathrooms, 410.4(D)
 Not in clothes closets, 410.8(C)
Screw-shell types for lamps only, 410.47
Unswitched over combustible material, 410.6
- Lamps**, Art. 410. *see also* Luminaires (lighting fixtures)
Clothes closets, in, 410.8
Electric discharge, 410.30(C), 410.54, 410-XIII, 410-XIV
Fluorescent. *see* Fluorescent luminaires (lighting fixtures)
Guards. *see* Guarding, guards
Incandescent. *see* Incandescent lamps
Outdoor, location, 225.25
Portable. *see* Portable lamps
- Laundry**
Circuit load, 220.52(B)
Outlets
 Dwelling, 210.11(C)(2), 210.50(C), 210.52(F)
 Ground-fault circuit interrupters, 210.8(A)(7)
- Laundry area**, 210.52(F)
- Lengths**
Free conductors at outlets and switches, 300.14, 424.43
Pull and junction boxes, 314.28
Space heating cable, nonheating leads, 424.34
Taps, 210.19(A)(4)Ex. 1
- Lighting**
Branch circuits, calculation of load, 220.12
Cove, 410.9
Electric discharge. *see* Electric discharge lighting
Feeders, calculation of load, 220.42, 220-IV
Festoon. *see* Festoon lighting
Fixtures. *see* Luminaires (lighting fixtures)
Outlets. *see* Lighting outlets
Systems. *see* Lighting systems, 30 volts or less
Track. *see* Lighting track
- Lighting assembly, cord- and plug-connected**
Definition, 680.2
- Lighting outlets**, 210.70, 314.27(A), 410-III, 410.16(A)
Definition, Art. 100-I
- Lighting systems, 30 volts or less**, Art. 411
Branch circuit, 411.6
Definition, 411.2
Hazardous (classified) locations, 411.7
Listing required, 411.3
Locations not permitted, 411.4
Secondary circuits, 411.5
- Lighting track**, 220.43(B), 410-XV
Construction requirements, 410.105
Definition, 410.100
Fastening, 410.104
Installation, 410.101
- Lightning rods**
As a ground, 250.60
Spacing from, 250.106 FPN
- Lightning (surge) arresters**, Art. 280
Connections at services, 230.82(4)
Grounding, 250.60, 250.106, 280.25
- Lightning (surge) protection**, Art. 280
Network-powered broadband communications systems, 830.40(I)(3)
- Liquidtight flexible metal conduit (Type LFMC)**, Art. 350
Bends, 350.24, 350.26
Couplings and connectors, 350.42
Definition, 350.2
Grounding and bonding, 350.60
Installation, 350-II
Listing, 350.6
Maximum number of conductors and fixture wires in, Tables C7 and C7A
Number of conductors and cables in, 350.22
Securing and supporting, 350.30
Size, 350.20
Uses not permitted, 350.12
Uses permitted, 350.10
- Liquidtight flexible nonmetallic conduit (Type LFNC)**, Art. 356
Bends, 356.24, 356.26
Couplings and connectors, 356.42
Definition, 356.2
Grounding and bonding, 350.60
Installation, 356-II
Listing, 356.6

- Maximum number of conductors and fixture wires in,
 - Tables C5 through C6A
- Number of conductors or cables in, 356.22
- Securing and supporting, 350.30, 356.30
- Size, 356.20
- Splices and taps, 356.56
- Trimming, 356.28
- Uses not permitted, 356.12
- Uses permitted, 356.10
- Listed**
 - Definition, Art. 100-I
- Live parts.** *see also* Enclosures; Energized parts; Guarding, guards
 - Definition, Art. 100-I
 - Exposed, 110.26
 - Guarding, 110.27
 - Lighting systems, electric discharge, 410-XIII, 410-XIV
 - Luminaires (lighting fixtures) and lamps, 410.3, 410.46
- Loads**
 - Appliances, household cooking, demand table, 220.55
 - Branch circuits
 - Calculations, Art. 220, Annex D
 - Maximum, 210.25, 220.18
 - Permissible, 210.23, 210.24, Table 210.24
 - Continuous. *see* Continuous load
 - Demand
 - Clothes dryers, 220.54
 - Household cooking appliances, 220.55
 - Feeder, 220-III, Annex D
 - Calculations, Art. 220
 - Inductive. *see* Inductive loads
 - Mobile home parks, 550.31
- Locations**
 - Damp or wet. *see* Damp or wet locations
 - Definition, Art. 100-I
 - Dry. *see* Dry location
 - Grounding connections at electrodes, 250.68
 - Lamps, outdoors, 225.25
 - Luminaires (lighting fixtures), 410-II
 - Outlet boxes and conduit boxes, 314.29
 - Overcurrent devices, 240-II
 - Overhead service, 230.54
 - Panelboards, damp or wet, 408.17
 - Protective devices for communications circuits, 800.30, 830.30
 - Service disconnecting means, 230.70(A), 230.72(A) Ex.
 - Service overcurrent protection, 230.91, 230.92
 - Swimming pool junction box and transformer enclosures, 680.24
 - Switches, wet, 404.4
 - System grounding connections, 250-II
 - Transient voltage surge suppressors, 285.11
 - Wet. *see* Wet locations; Damp or wet locations
- Low-voltage circuits.** *see also* Remote-control, signaling, and power-limited circuits
- Lugs**
 - Connection to terminals, 110.14(A)
 - Listed type at electrodes, 250.70
- Luminaire (fixture) stud construction,** 410.16(D)
- Luminaires (lighting fixtures),** Art. 410.
 - Autotransformers
 - Supply circuits, 210.9, 215.11
 - Bathtubs, near, 410.4(D)
 - Boxes, canopies, pans, 410.38, 410-III
 - Branch circuits
 - Computation of, 210.19(A), 220.12, 220.14 and (B)
 - Sizes, 210.23, 220.18
 - Voltages, 210.6, 410.73
 - Clothes closets, 410.8
 - Definition, 410.8(A)
 - Combustible material, near, 410.5, 410.76
 - Connection, fluorescent, 410.14, 410.30(C)
 - Construction, 410.105, 410-VI
 - Damp, wet, or corrosive locations, 410.4(A) and (B)
 - Dry-niche, 680.23(C)
 - Definition, 680.2
 - Electric discharge. *see* Electric discharge lighting
 - Fluorescent. *see* Fluorescent lighting luminaires (fixtures)
 - Flush, 410-XI, 410-XII
 - Grounding, 410-V
 - Live parts, 410.3
 - Location, 410-II
 - Mounting, 410.76, 410.77
 - No-niche, 680.23(D), 680.24(B), 680.26(B)(2)
 - Definition, 680.2
 - Outlets required, 210.70. *see also* Lighting outlets
 - Overcurrent protection, wires and cords, 240.4
 - Polarization, 410.23
 - Raceways, 410.15(B), 410.31
 - Recessed. *see* Recessed luminaires (lighting fixtures)
 - Showers, near, 410.4(D)
 - Supports, 410-IV
 - Swimming pools, spas, and similar installations,
 - 680.22(B), 680.23, 680.26(B)(2), 680.33, 680.43(B), 680.72
 - Wet, 410.4(A)
 - Wet-niche, 680.23(B)
 - Definition, 680.2
 - Wiring, 410-VI

-M-**Made electrodes**, 250.50, 250.52**Mandatory rules**, 90.5(A)**Manufactured home.** *see also* Mobile homes; Recreational vehicles

Definition, 550.2

Markings, 110.21. *see also* identification; subhead under entries for specific wiring and equipment**Mechanical execution of work**, 110.12, 725.8, 760.8, 800.24, 820.24, 830.24**Metal-clad cable (Type MC)**, Art. 330

Accessible attics, 330.23

Ampacity, 330.80

Bends, 330.24

Boxes and fittings, 330.40

Definition, 330.2

Installation, 330-II

Marking, 310.11(B)(2) Ex. 3

Single conductors, 330.31

Supports, 330.30

Through or parallel to framing members, 300.4(A), 330.17

Uses not permitted, 330.12

Uses permitted, 330.10

Metal frame of building

Grounding electrode, 250.52(A)(2)

Not permitted as equipment grounding conductor, 250.136(A)

Metal outlet boxes. *see* Boxes, metal**Metals**Corrosion, protection against. *see* Protection, corrosion

Dissimilar, 110.14, 250.70, 342.14, 344.14

Ferrous, 300.6(A)

Metal siding, grounding of, 250.116 FPN**Meter socket enclosures**, 312.1. *see also* Cabinets, cutout boxes, and meter socket enclosures**Meters**

Connection and location at services, 230.82, 230.94 Ex. 5

Grounding to grounded circuit conductor, 250.142(B) Ex. 2

Metric equivalents

Raceways, trade sizes, 300.1(C)

Metric units of measurement, 90.9**Mobile home lot**

Definition, 550.2

Mobile home parks, Art. 550

Definitions, 550.2

Distribution system, 550.30

Feeder and service demand factors, 550-III, 550.31, Table 550.31

Minimum allowable demand factor, 550.31

Mobile home service equipment, 550.32

Definition, 550.2

Mobile homes, Art. 550

Communications circuits, 800.106

Definitions, 550.2

Feeder, 550.33

Service equipment, 550.32

Definition, 550.2

Mounting of equipment, 110.13, 314.23, 404.10, 409.9(A), 410-IV**Multioutlet assembly**, Art. 380

Calculation of load, 220.14(H)

Definition, Art. 100-I

Metal, through dry partitions, 380.3

Use, 380.2

Multiple conductors (conductors in parallel). *see* Conductors, multiple**Multiwire branch circuit**, 210.4

Definition, Art. 100-I

-N-**Nameplates.** *see* subhead under entries for specific wiring and equipment**Neat and workmanlike installation**, 110.12, 725.8, 760.8, 800.24, 820.24, 830.24**Network-powered broadband communications systems**, Art. 830

Buildings, 830-II, 830-V

Cables outside and entering buildings, 830-II

Aerial cables, 830.44:

Above roofs 830.44(F); Clearance from ground 830.44(D); Final spans 830.44(G); On buildings 830.44(I); Over pools 830.44(E)

Entrance cables, 830.40:

Low power circuits 830.40(B); Medium power circuits 830.40(A)

Underground circuits entering buildings, 830.47

Direct-buried cables and raceways, 830.47(B)

Mechanical protection, 830.47(C)

Pools, 830.47(D)

Wiring methods within, 830-V

Low power wiring, 830.154:

Ducts, plenums, other air handling spaces, 830.154(A); Other wiring 830.154(C); Riser, 830.154(B)

Medium power wiring, 830.151: Ducts, plenums, other air handling spaces 830.151(A); Other wiring 830.151(C), Riser 830.151(B)

Protection against physical damage, 830.157

- General, 830-I
 - Access to electrical equipment behind panels, 830.21
 - Definitions, 830.2
 - Locations and other articles, 830.3
 - Mechanical execution of work, 830.24
 - Scope, 830.1
 - Grounding methods, 830-IV
 - Bonding and grounding at mobile homes, 830.106
 - Cable network interface unit, and primary protection, 830.100
 - Protection, 830-III
 - Grounding of metallic members, 830.93
 - Primary electrical protection, 830.90
 - Neutral.** *see also* Conductors, grounded
 - Bare, 230.22 Ex., 230.30 Ex., 230.41 Ex.
 - Bonding to service equipment, 250.92
 - Common. *see* Common neutral
 - Conductor 310.15(B)(6)
 - Continuity of, 300.13
 - Equipment, grounding to, 250.142
 - Feeder load, 220.61
 - Grounding of
 - AC systems, 250.4, 250.24, 250.26, 250.34, 250.36
 - Identification, Art. 200
 - Ranges and dryers, grounding, 250.140, 250.142
 - Uninsulated, where permitted, 230.22 Ex., 230.30 Ex., 230.41 Ex., 250.140(3), 338.10(B)
 - Nipples, conduit.** *see* Conduit nipples
 - Nonelectrical equipment, grounding,** 250.116
 - Nongrounding-type receptacles, replacements,** 250.130(C), 406.3(D)
 - Nonmetallic boxes.** *see* Boxes, nonmetallic
 - Nonmetallic conduit.** *see* Liquidtight flexible nonmetallic conduit
 - Nonmetallic rigid conduit.** *see* Rigid nonmetallic conduit
 - Nonmetallic-sheathed cable (Types NM, NMC, and NMS), Art. 334**
 - Accessible attics, 334.23
 - Bends, 334.24
 - Boxes and fittings, 334.40
 - Definition, 334.2
 - Devices of insulating material, 334.40(B)
 - Devices with integral enclosures, 334.40(C)
 - Exposed work, 334.15
 - Installation, 334-II
 - Listed, 334.6
 - Marking, 310.11
 - Nonmetallic outlet boxes, 334.40(A)
 - Supports, 334.30
 - Through or parallel to framing members, 300.4, 334.17
 - Unfinished basements, 334.15(C)
 - Uses not permitted, 334.12
 - Uses permitted, 334.10
 - Nonpower-limited fire alarm circuit (NPLFA), 760-II**
 - Definition, 760.2
- O-**
- Occupancy, lighting loads,** 220.12, Table 220.12
 - Official interpretations.** *see* Formal interpretations
 - Openings in equipment to be closed,** 110.12(A), 312.5(A), 314.17(A)
 - Optional standby systems, Art. 702**
 - Capacity and rating, 702.5
 - Circuit wiring, 702-II
 - Definition, 702.2
 - Equipment approval, 702.4
 - Grounding, 702-III
 - Portable generator grounding, 702.10
 - Signals, 702.7
 - Signs, 702.8
 - Transfer equipment, 702.6
 - Outdoor receptacles,** 210.8(A)(3), 210.52(E), 406.8, 680.22(A), 680.32
 - Outlet boxes.** *see* Boxes
 - Outlet spacing, dwelling baseboard heaters,** 210.52
 - Outlets**
 - Appliance, 210.50(C)
 - Definition, Art. 100-I
 - Devices, branch circuits, 210.7
 - Heating, air-conditioning, and refrigeration equipment, 210.63
 - Laundry. *see* Laundry
 - Lighting. *see* Lighting outlets
 - Multioutlet assembly. *see* Multioutlet assembly
 - Receptacle, 210.50
 - Definition, Art. 100-I
 - Dwellings, where required, 210.52
 - Required, 210-III
 - Outside branch circuits and feeders, Art. 225**
 - Calculation of load, 225.3
 - Branch circuits, 220-I, 220-II, 225.3(A)
 - Feeders, 220-III, 225.3(B)
 - Circuit entrances and exits, buildings, 225.11
 - Conductors
 - Clearance
 - From buildings, 225.19
 - From ground, 225.18
 - Covering, 225.4
 - Size, 225.5, 225.6
 - Disconnection, 225.31

- Lighting equipment installed outdoors, 225.7
 - Location of outdoor lamps, 225.25
 - Mechanical protection, 225.20
 - More than one building or structure, 225-II
 - Access to occupants, 225.35
 - Access to overcurrent protective devices, 225.40
 - Disconnect
 - Construction, 225.38
 - Disconnecting means, 225.31
 - Grouping of, 225.34
 - Location of, 225.31
 - Maximum number, 225.33
 - Rating of, 225.39
 - Suitable for service equipment, 225.36
 - Identification, 225.37
 - Number of supplies, 225.30
 - Outdoor lampholders, 225.24, 225.25
 - Overcurrent protection, 225.9
 - Point of attachment, 225.16
 - Spacing, open conductors, 225.14
 - Supports
 - Open conductors, 225.12
 - Over buildings, 225.15
 - Vegetation, 225.26
 - Wiring on buildings, 225.10
 - Outside of buildings, when services considered**, 230.6
 - Ovens, wall-mounted.** *see also* Cooking units, counter-mounted; Ranges
 - Branch circuits, 210.19(A)(3), 210.23, 220.55, Table 220.55 Note 4
 - Connections, 422.16(B)(3), 422.31(B)
 - Definition, Art. 100-I
 - Demand loads, Table 220.55
 - Grounding, 250.134, 250.140
 - Overcurrent**
 - Definition, Art. 100-I
 - Overcurrent devices.** *see* Overcurrent protection
 - Overcurrent protection**, Art. 240
 - Air-conditioning and refrigerating equipment, 440-III
 - Appliances, 422.11
 - Single, 210.20
 - Branch circuits, 210.20, 240.3
 - Communications systems. *see* Communications circuits, protection
 - Electric space heating equipment, 424.22
 - Enclosures, 240-III
 - Fuses and fuseholders, 240-V
 - Location, 230.91, 240-II
 - Occupant access to, 240.24(B)
 - Panelboards, 408.35, 408.36
 - Remote-control circuits, 240.4(G), Art. 725
 - Services
 - Equipment, 230-VII
 - Vertical position, enclosures, 240.33
 - Overhead spans**, 225.6(A)
 - Overload**
 - Definition, Art. 100-I
- P-**
- Panelboards**, Art. 408
 - Circuit directory, 408.4
 - Damp or wet locations, 408.37
 - Definition, Art. 100-I
 - Enclosure, 408.38
 - General, 408.30
 - Grounding, 408.40
 - Installation, 110.26(F)
 - Lighting and appliance branch-circuit
 - Definition, 408.34(A)
 - Number of overcurrent devices, 408.35
 - Overcurrent protection, 408.36
 - Relative arrangement of switches and fuses, 408.39
 - Service equipment, 230.79, 408.3(C), 408.36(A)
 - Use as enclosure, 312.8
 - Pans, fixture**, 410.13
 - Paralleled conductors.** *see* Conductors, paralleled
 - Parts.** *see* specific type such as Live parts
 - Path, grounding**, 250.2, 250.4(A)(5), 250.28
 - Pendants**
 - Bathrooms, 410.4(D)
 - Clothes closets, 410.8(C)
 - Connector, cord, 210.50(A)
 - Flexible cord, 400.7(A)(1)
 - Periodic duty**
 - Definition, Art. 100-I
 - Permanent plaque or directory**, 225.37, 230.2(E)
 - Permission, special**
 - Definition, Art. 100-I
 - Person, qualified**
 - Definition, Art. 100-I
 - Photovoltaic systems.** *see* Solar photovoltaic systems
 - Physical damage.** *see* Protection, physical damage
 - Pipe, gas.** *see* Gas pipe
 - Pipe electrodes**, 250.52(A)(1), 250.52(A)(5), 250.53, 250.56, 250.66(A), 250.70
 - Piping systems, bonding**, 250.104
 - Plate electrodes**, 250.52(A)(6), 250.53, 250.56, 250.66(A)
 - Plenums**, 300.22
 - Definition, Art. 100-I

- Network-powered broadband communications cables, 830.154(B)
- Wiring in, 300.22
- CATV coaxial cable, 820.113, 820.154(A)
 - Communications circuits, 800.154(A)
- Pliable raceways.** *see* Raceways, pliable
- Plugs, attachment.** *see* Attachment plugs
- Point of entrance**
- Definition, 800.2, 820.2, 830.2
- Polarization**
- Connections, 200.11
 - Luminaires (lighting fixtures), 410.23
 - Plugs, receptacles, and connectors, 200.10(B)
 - Screw-shell type lampholders, 410.47
- Poles**
- Conductors, mechanical protection, 225.20, 230.50
 - Supporting luminaires (lighting fixtures), 410.15(B)
- Pool covers.** *see* Covers
- Pools.** *see also* Swimming pools, fountains, and similar installations
- Definitions, 680.2
- Portable appliances.** *see* Appliances
- Portable equipment**
- Double insulation, 250.114 Ex.
 - Grounding, 250.114, 250.138
 - Conductor size, 250.122, Table 250.122
- Power-limited fire alarm circuit (PLFA)**
- Definition, 760.2
- Premises wiring (system)**
- Definition, Art. 100-I
- Pressure (solderless) connectors** Definition, Art. 100-I
- Prevention of fire spread.** *see* Fire spread
- Protection**
- Combustible material, appliances, 422.17
 - Corrosion
 - Electrical metallic tubing, 358.10(B)
 - General equipment, 300.6
 - Intermediate metal conduit, 342.10(B) and (D)
 - Rigid metal conduit, 344.10(B) and (D)
 - Ground fault. *see* Ground fault protection
 - Ground fault circuit-interrupter. *see* Ground fault circuit-interrupter
 - Live parts, 110.27
 - Physical damage
 - Armored cable, 320.12, 320.15
 - Conductors, 250.64(B), 300.4
 - Electrical metallic tubing, 358.12(1)
 - Electrical nonmetallic tubing, 362.12(10)
 - Lighting track, 410.101(C)(1)
 - Liquidtight flexible metal conduit, 350.12(1)
 - Liquidtight flexible nonmetallic conduit, 356.12(1)
 - Metal-clad cable, 330.12
 - Multioutlet assembly, 380.2(B)(2)
 - Nonmetallic-sheathed cable, 334.15(B)
 - Open conductors and cables, 230.50
 - Overcurrent devices, 240.24(C)
 - Raceways, 300.5(D)(4)
 - Rigid nonmetallic conduit, 352.12(C)
 - Space heating systems, 424.12(A)
 - UF cable, 340.12(10)
 - Underground installations, 230.49, 300.5(D) and (J)
- Protective devices.** *see* Arc-fault circuit-interrupters; Circuit breakers; Fuses; Ground-fault circuit-interrupters; Overcurrent protection
- Protective equipment.** *see* Guarding, guards
- Protector, communications systems.** *see* Communications circuits
- Pull boxes.** *see also* Boxes; Junction boxes
- Accessibility, 314.29
 - 4 AWG and larger conductors, 314.28(A)
 - 6 AWG and smaller conductors, 314.16
- Pumps**
- Pool, double insulated, 680.21(B), 680.31
 - Storable pools, 680.21
- Q-**
- Qualified person.** *see* Person, qualified
- R-**
- Raceways**
- Bonding, 250-V
 - Conductors in service, 230.7
 - Continuity, 300.10, 300.12
 - Definition, Art. 100-I
 - Drainage, 225.22, 230.53
 - Electrical metallic tubing (Type EMT). *see* Electrical metallic tubing (Type EMT)
 - Electrical nonmetallic tubing (Type ENT). *see* Electrical nonmetallic tubing (Type ENT)
 - Expansion joints, 352.44
 - Flexible metallic tubing (Type FMC). *see* Flexible metallic tubing (Type FMC)
 - Grounding, 250.132, 250-IV
 - Short sections, 250.86 Ex. 2, 250.132
 - Induced currents, 300.20
 - Installed in shallow grooves, 300.4(E)
 - Insulating bushings, 300.4(F), 300.16(B)
 - Intermediate metal conduit (Type IMC). *see* Intermediate metal conduit (Type IMC)

- Liquidtight flexible metal conduit (Type LFMC). *see* Liquidtight flexible metal conduit (Type LFMC)
- Liquidtight flexible nonmetallic conduit (Type LFNC). *see* Liquidtight flexible nonmetallic conduit (Type LFNC)
- Luminaires (fixtures) as, 410.31
- Number of conductors, 300.17. *see also* Conductor fill
- Pliable, 362.2
- Rigid metal conduit (Type RMC). *see* Rigid metal conduit (Type RMC)
- Rigid nonmetallic conduit (Type RNC). *see* Rigid nonmetallic conduit (Type RNC)
- Secured, 300.11(A)
- Service. *see* Service raceways
- Support for nonelectrical equipment, 300.11(B)
- Underground, 300.5(C)(4)
- Rainproof**
Definition, Art. 100-I
- Raintight**
Definition, Art. 100-I
- Ranges**, 422.16(B)(3), 422.33(B). *see also* Cooking unit, counter-mounted; Ovens, wall-mounted
- Branch circuits, 210.19(A)(3)
- Calculation of load, 220.55, Table 220.55
- Conductors, 210.19
- Maximum load, 220.18
- Feeders, calculation of load, 220.40, 220.82(B)(3)
- Grounding, 250.140
- Hoods, cord-and-plug connected, 422.16(B)(4)
- Loads, demand factors and, Table 220.55
- Receptacles, 250.140(4)
- Rated load current**, 440.4(A)
Definition, 440.2
- Readily accessible.** *see* Accessible, readily
- Reaming, ends of metal conduits**, 342.28, 344.28, 358.28
- Re-bar electrodes**, 250.50 Ex., 250.52(A)(3)
- Receptacles, cord connectors and attachment plugs (caps)**, Art. 406
- Branch circuits, 210.7, 210.52
- Definition, Art. 100-I
- Disconnecting means, 422.33, 440.63
- Faceplates, 406.4, 406.5
- Grounding type, 250.130(C), 250.146, 406.3(A), 406.9
- Maximum cord- and plugconnected load to, 210.21(B)(2), Table 210.21(B)(2), 210.23
- Minimum ratings, 406.2(B)
- Nongrounding-type, replacement, 250.130(C), 406.3(D)
- Outdoor. *see* Outdoor receptacles
- Outlets, 210.50
Definition, Art. 100-I
- Outlets, where required, dwellings, 210.52
- Ratings for various size circuits, 210.21(B)(3), Table 210.21(B)(3)
- Replacement, 406.3(D)
- Swimming pools, 680.22(A), 680.32, 680.34, 680.43(A)
- Temporary installations, 590.4(D), 590.6
- Terminals, identification, 200.10(B)
- Recessed luminaires (lighting fixtures)**, 410-XI, 410-XII
- Clearances, installation, 410.66
- As raceways, 410.31
- Temperatures, 410.65
- Wiring, 410.67
- Refrigeration compressor motors and controls**, Art. 440
- Refrigeration equipment.** *see* Airconditioning and refrigeration equipment
- Refrigerators, grounding**, 250.114
- Remote-control.** *see* Remote-control, signaling, and power-limited circuits
- Remote-control, signaling, and power-limited circuits**, 250.112(I), Art. 725
- Access to electrical equipment, 725.7
- Class 1 circuits, 725-II
- Grounding, 725.9
- Locations, 725.3
- Physical protection, 725.8(B)
- Power limitations, 725.21
- Wiring methods, 725.25
- Class 2 and Class 3 circuits, 725-III
- Conductors, 725.52
- Interconnection of power supplies, 725.41(B)
- Locations, 725.3
- Power sources, 725.41(A)
- Separation, 725.55
- Wiring methods
- Load side, 725.52
- Classifications, definitions, 725.2
- Class 1, 725-II
- Class 2 and Class 3, 725-III
- Identification, 725.10
- Location and other articles, 725.3
- Mechanical execution of work, 725.8
- Safety-control equipment, 725.11
- Requirements for electrical installations**, Art. 110
- Residential occupancies.** *see* Dwellings
- Resistance**
- Conductor properties, Chap. 9, Table 8
- Insulation, 110.7
- Rigid metal conduit (Type RMC)**, Art. 344
- Bends, 344.24, 344.26
- Bushings, 344.46

- Cinder fill, 344.10(C)
 - Couplings and connectors, 344.42
 - Definition, 344.2
 - Dissimilar metals, 344.14
 - Ferrous, 300.6(A)
 - Grounding, 344.60
 - Installation, 344-II
 - Listing, 344.6
 - Maximum number of conductors and fixture wires in,
 - Tables C8 and C8(A)
 - Number of conductors, 344.22, Chap. 9, Table 1
 - Reaming and threading, 344.28
 - Securing and supporting, 314.23(E) and (F), 344.30
 - Size, 344.20
 - Splices and taps, 344.56
 - Uses permitted, 344.10
 - Wet locations, 344.10(D)
 - Rigid nonmetallic conduit (Type RNC), Art. 352**
 - Bends, 352.24, 352.26
 - Bushings, 352.46
 - Expansion fittings, 352.44, Tables 352.44(A) and 352.44(B)
 - Joints, 352.48
 - Maximum number of conductors and fixture wires in,
 - Tables C9 through C12(A)
 - Number of conductors, 352.22
 - PVC Schedule 80, 300.5(D)
 - Size, 352.20
 - Splices and taps, 352.56
 - Supporting and securing, 352.30, Table 352.30(B)
 - Trimming ends, 352.28
 - Uses not permitted, 352.12
 - Uses permitted, 352.10
 - Rod electrodes**, 250.52(A)(5), 250.53, 250.56, 250.66(A), 250.70
 - Room air conditioners.** *see* Air conditioners, room
 - Running threads**, 342.42(B), 344.42(B)
- S-**
- Safety, examination of equipment for**, 90.7
 - Screw shells**
 - Identification
 - Polarity, 200.10(C), 410.23
 - Terminals, 200.10
 - Service cables.** *see* Service-entrance cable (Types SE and USE)
 - Service conductors.** *see* Conductors, service
 - Service drops**
 - Clearances, 230.24
 - Connections, service head, 230.54
 - Definition, Art. 100-I
 - Means of attachment, 230.27
 - Minimum size, 230.23
 - Point of attachment, 230.26, 230.28
 - Supports over buildings, 230.29
 - Service-entrance cable (Types SE and USE), Art. 338**
 - Bends, 338.24
 - Branch circuits or feeders, 338.10(B)
 - Definition, 338.2
 - Grounding frames of ranges and clothes dryers, 250.140(3)
 - Installation, 338-II
 - Installation methods, for branch circuits and feeders, 338.10(B)(4)
 - Service-entrance conductors, Art. 230-IV, 338.10(A)
 - Uses permitted, 338.10
 - Service-entrance conductors**, 230-IV, 338.10(A)
 - Conductor sets, number of, 230.40
 - Considered outside of building, 230.6
 - Definitions, Art. 100-I
 - Disconnecting means, 230-VI
 - Drip loops, 230.52
 - Insulation, 230.41
 - Overcurrent protection, 230.90, 230.91
 - Physical damage, 230.49, 230.50
 - Underground, 230.49
 - Service head, 230.54
 - Size, 230.42
 - Splices, 230.46
 - Underground, 230.49
 - Definition, Art. 100-I
 - Wiring methods, 230.43
 - Service-entrance equipment**
 - Disconnecting means, 230-VI
 - Connections, supply side, 230.82
 - Connections to terminals, 230.81
 - Grounded conductor, disconnection of, 230.75
 - Indicating, 230.77
 - Location, 230.70(A)
 - Marking, 230.66, 230.70(B)
 - Maximum number of disconnects, six switch rule, 230.71
 - Multiple occupancy buildings, 230.72(C)
 - Rating, 230.79
 - Simultaneous openings, 230.74
 - Six switch rule, 230.71
 - Suitable for use, 230.70(C)
 - Guarding, 230.62
 - Overcurrent protection, 230-VI
 - Location, 230.91

- Relative location, 230.94
- Specific circuits, 230.93
- Ungrounded conductors, 230.90(A)
- Panelboards as, 408-III
- Service equipment**
 - Definition, Art. 100-I
 - Overcurrent protection, 230-VII
- Service lateral**
 - Definition, Art. 100-I
- Service loads, calculations, Art. 220, Annex D**
- Service point**
 - Definition, Art. 100-I
- Service raceways**
 - Conductors, others permitted in, 230.7
 - Drainage, raintight, 230.53
 - Service head, 230.54
 - Underground, 230-III
- Services, Art. 230**
 - Definition, Art. 100-I
 - Insulation, 230.22
 - Number, 230.2
 - Overhead supply, 230-II
 - Supply to one building not through another, 230.3
 - Underground, 230-III
- Setting (of circuit breaker)**
 - Definition, Art. 100-I
- Short-circuit current rating**
 - Definition, 110.10
 - Transient voltage surge suppressors, 285.6
- Short-time duty**
 - Definition, Art. 100-I
- Signaling circuits.** *see also* Fire alarm systems; Remote-control, signaling, and power-limited circuits
 - Definition, Art. 100-I
 - Installation requirements, Art. 725, Art. 760
- Snap switches**
 - Accessibility, grouping, 404.8
 - Definition, Art. 100-I
 - Grounding, 409.9(B)
 - Panelboards, 408.36(C), 408.39
 - Ratings, 404.14
- Solar photovoltaic systems, Art. 690**
- Solderless (pressure) connector.** *see* Connectors, pressure (solderless)
- Space**
 - Cabinets and cutout boxes, 312.7
 - Lightning rods, conductor enclosures, equipment, 250.60, 250.106 FPN
 - Outside branch circuits and feeders, 225.14
 - Working. *see* Working space
- Space heating, fixed.** *see* Fixed electric space heating equipment
- Spas and hot tubs, 680-IV**
 - Definitions, 680.2
 - Indoor installations, 680.43
 - Outdoor installations, 680.42
 - Packaged equipment assembly
 - Definition, 680.2
 - Protection, 680.43, 680.43(A)(2)
- Special permission.** *see* Permission, special
- Splices and taps**
 - Cabinets and cutout boxes, 312.8
 - Conduit bodies, 300.15, 314.16(C)(2)
 - Construction sites, 590.4(G)
 - Electrical metallic tubing, 358.56
 - Flexible cords and cables, 400.9
 - General provisions, 110.14
 - Underground, 300.5(E)
- Spread of fire or products of combustion.** *see* Fire spread
- Standby systems.** *see* Optional standby systems
- Steel, structural, bonding, 250.104(C)**
- Steel siding, 250.116 FPN**
- Support fittings fill, boxes, 314.16(B)(3)**
- Supports.** *see* subhead under entries for specific wiring and equipment
- Surge arresters.** *see* Lightning (surge) arresters
- Surge protection.** *see* Lightning (surge) protection
- Surge suppressors.** *see* Transient voltage surge suppressors (TVSSs)
- Swimming pools, fountains, and similar installations, Art. 680**
 - Approval of equipment, 680.4
 - Bonding, 680.26, 680.42(B), 680.43(D) and (E), 680.74
 - Ceiling fans, 680.22(B), 680.43(B)
 - Cord- and plug-connected equipment, 680.7, 680.21(5), 690.22(B)(5), 680.31, 680.42(A)(2)
 - Deck area heating, 680.27(C)
 - Definitions, 680.2
 - Ground-fault circuit-interrupters, 680.5
 - Hydromassage bathtubs, 680.71
 - Junction boxes for, 680.24
 - Luminaires (lighting fixtures), 680.23(A)(3), 680.24(B)
 - Pool covers, 680.27(B)(2)
 - Receptacles, 680.5, 680.6, 680.22(A)(5), 680.32, 680.43(A), 680.44
 - Spas, hot tubs, 680.43, 680.44
 - Storable pool equipment, for, 680.32, 680.33(B)(3)
 - Wiring to, 680.24(B)
 - Grounding, 680.6, 680.7(B), 680.23(B)(3) and (F)(2), 680.24(D) and (F), 680.25(B), 680.43(F)

- Hydromassage bathtubs, 680-VII
- Junction boxes and enclosures, 680.24
- Lighting, 680.22(B), 680.23, 680.26(B)(2), 680.33, 680.43(B), 680.72
- Overhead conductor clearances, 680.8
- Permanently installed, 680-II
- Receptacles, location and protection, 680.22(A), 680.32, 680.34, 680.43(A)
- Spas and hot tubs, 680-IV
- Storable, 680-III
- Definition, 680.2
- Switches and switching devices, 680.22(C), 680.41
- Transformers, 680.23(A)(2), 680.24(B)
- Underwater audio equipment, 680.23, 680.26(B)(2), 680.33, 680.43(B)(2)
- Underwater luminaires (lighting fixtures), 680.23, 680.26(B)(2), 680.33, 680.43(B)(2)
- Switches**, Art. 404
- AC general use snap switch, 404.14(A)
- Accessibility, 404.8
- AC-DC general use snap switches. *see* AC-DC general use snap switches
- Air-conditioning and refrigerating equipment, 440-II
- Appliances, 422.34
- Definitions, Art. 100-I
- Disconnecting means
- Appliances, 422-III
- Services, 230-VI
- General use, Art. 404
- Definition, Art. 100-I
- Identification, 110.22
- Manually operable, Art. 404
- Panelboards, 408.36(C), 408.39
- Service, 230-VI
- Snap. *see* Snap switches
- Unit, appliances, 422.34
- T-**
- Tables**, Chap. 9, and Annex C
- Ampacities
- General conductors, 0 through 2000 volts
- Aluminum, copper, or copper-clad aluminum in raceways or cables types AC, NM, NMC SE, Table 310.16
- Branch-circuit requirements, Table 210.24
- Cable substitutions, 725.61, 760.61, 800.154, 820.154(G), 830.133(C)
- Calculation of feeder loads by occupancies, Table 220.42
- Conductors
- Conduit and tubing fill for, Annex C Tables
- Deflection, minimum bending space in cabinets, cutout boxes, Tables 312.6(A), 312.6(B)
- Dimensions
- Compact aluminum building wiring, Chap. 9 Table 5A
- Insulated conductors, and fixture wires, Chap. 9 Table 5
- Rubber, thermoplastic covered, Chap. 9 Table 5
- Grounding, size
- For AC equipment, Table 250.122
- For grounded systems, Table 250.66
- Maximum number, Annex C Tables
- Maximum number in
- Electrical metallic tubing, Tables C1, C1(A)
- Electrical nonmetallic tubing, Tables C2, C2(A)
- Flexible metal conduit, Tables C3, C3(A)
- Intermediate metal conduit, Tables C4, C4(A)
- Liquidtight flexible metal conduit, Tables C7, C7(A)
- Liquidtight flexible nonmetallic conduit, Tables C5, C5(A), C6, C6(A)
- Rigid metal conduit, Tables C8, C8(A)
- Rigid nonmetallic conduit, Tables C9 through C10(A)
- Metal boxes, number in, Table 314.16(A)
- Minimum size of, Table 310.5
- Properties, Chap. 9 Table 8
- Volume required per conductor, Table 314.16(B)
- Conduit and tubing fill, for conductors, Annex C Tables
- Conduit or tubing
- Combination of conductors, percent area fill, Chap. 9 Table 1
- Dimensions, Chap. 9 Table 4
- Expansion characteristics, Tables 352.44(A), 352.44(B)
- Flexible metal (trade size 3/8 in.), Table 348.22
- Number of conductors in, Annex C Tables
- PVC rigid nonmetallic, expansion characteristics, 352.44(A)
- Radius of bends, Chapter 9, Table 2
- Supports, Tables 344.30(B)(2), 352.30(B)
- Cooking appliances, demand factors and loads, Tables 220.19
- General lighting unit loads by occupancies, Table 220.12
- Household clothes dryers, demand loads, Table 220.54
- Household ranges and similar cooking appliances, demand loads, Table 220.55
- Live parts, separation
- Working clearances, Table 110.26(A)(1)
- Mobile home park demand factors, Table 550.31
- Multifamily dwellings, optional calculation demand factors, Table 220.84

- Network-powered broadband communications systems
 - Cable substitution, Table 830.133
 - Cover requirements, Table 830.47
 - Underground wiring, minimum cover, Tables 300.5
 - Wire bending space, minimum, Tables 312.6(A), 312.6(B)
 - Taps.** *see also* Splices and taps
 - Branch circuit, 210.19(A)
 - Overcurrent protection, 240.21
 - Service-entrance conductors, 230.46
 - Telephone equipment,** 800.18. *see also* Communication circuits
 - Telephone systems.** *see* Communication circuits
 - Television and radio distribution systems.** *see* Community antenna television and radio distribution (CATV) systems
 - Temperature limitations**
 - Conductors, 310.10
 - Nonmetallic raceways and tubing. *see* subhead under entries for specific raceway or tubing type
 - In outlet boxes for luminaires (fixtures), 410.11
 - Service-entrance cable, 338.10(B)(3)
 - Temporary installations,** Art. 590
 - All wiring installations, 590.2
 - Branch circuits, 590.4(C)
 - Disconnecting means, 590.4(E)
 - Feeders, 590.4(B)
 - Ground-fault protection, 590.6
 - Lamp protection, 590.4(F)
 - Protection from accidental damage, 590.4(H)
 - Receptacles, 590.4(D), 590.6(A), 590.6(B)
 - Services, 590.4(A)
 - Splices, 590.4(G)
 - Terminations at devices, 590.4(I)
 - Time constraints, 590.3
 - Terminals**
 - Connections to, 110.14, 250.8, 250.68
 - Identification
 - Polarity, 200.9 through 200.11
 - Wiring device, 250.126
 - Thermally protected (thermal protection)**
 - Fixtures, recessed, 410.65(C)
 - Fluorescent lamp ballasts in luminaires (fixtures), 410.73(E)
 - Luminaires (fixtures), recessed, 410.65(C)
 - Tools**
 - Double insulated, 250.114 Ex.
 - Motor-operated, hand-held, grounding, 250.114(3)(C), 250.114(4)(C)
 - Track lighting.** *see* Lighting track
 - Transfer switch**
 - Definition, Art. 100-I
 - Transient voltage surge suppressors: (TVSSs),** Art. 285
 - Conductor routing, 285.12
 - Connection, 285.21, 285-III
 - Definition, 285.2
 - Installation, 285-II
 - Listing, 285.5
 - Location, 285.11
 - Number required, 285.4
 - Short circuit current rating, 285.6
 - Uses not permitted, 285.3
 - Trees, luminaires (lighting fixtures) supported by,** 410.16(H)
 - Tubing.** *see also* Conduits
 - Electrical metallic. *see* Electrical metallic tubing
 - Electrical nonmetallic. *see* Electrical nonmetallic tubing
- U-**
- Underground feeder and branch circuit cable (Type UF),** Art. 340
 - Ampacity, 340.80
 - Bending radius, 340.20
 - Definition, 340.2
 - Equipment grounding conductor, 340.108
 - Installation, 340-II
 - Uses not permitted, 340.12
 - Uses permitted, 340.10
 - Underground wiring**
 - Buried conductors, Type USE, 338.10(B)(2), Type UF, 340.10
 - Conductor types in raceways, 310.7
 - Dry and damp locations, 310.8(B)
 - Ground movement and, 300.5(J)
 - Intermediate metal conduit, 342.10(B) and (C)
 - Liquidtight flexible metal conduit, 350.10(3)
 - Minimum cover requirements, 300.5(A)
 - Protection of, 300.5(D), 300.5(J)
 - Rigid metal conduit, 344.10
 - Rigid nonmetallic conduit, 352.10(G)
 - Services, 230.30, 230.32
 - “S” loops, 300.5(J) FPN
 - Splices and taps, 300.5(E)
 - Swimming pools, 680.10
 - Wet locations, 310.8(C)
 - Unused openings**
 - Boxes and fittings, 110.12(A), 408.7
 - Utilization equipment**
 - Definition, Art. 100-I

-V-**Varying duty**

Definition, Art. 100-I

Vaults

Service 600 volts or less, 230.6(3)

Ventilating ducts, wiring, 300.21, 300.22**Ventilation**

Equipment, general, 110.13(B)

Voltage and volts

Branch circuits, limits, 210.6

Circuit

Definition, Art. 100-I

Drop

Branch circuits, 210.19(A) FPN No. 4

Conductors, 310.15(A)(1) FPN No. 1

Feeders, 215.2(A) FPN No. 2

Electric discharge lighting, 410-XIII, 410-XIV

General provisions, 110.4

Ground to

Definition, Art. 100-I

Nominal Definition, Art. 100-I

Swimming pool underwater lighting fixtures,
680.23(A)(4)

Wiring methods, 300.2

-W-**Wading pools**

Definition, 680.2

Wall-mounted ovens. *see* Ovens, wall-mounted**Water heaters**, 422.11(F)(3), 422.13**Water pipe**

Bonding (metal), 250.104

Connections, 250.8, 250.68(B)

As grounding electrode, 250.52(A)(1), 250.53(D)

Watertight

Definition, Art. 100-I

Weatherproof

Definition, Art. 100-I

Wet locations. *see also* Damp or wet locations

Conductors, types, 310.8(C)

Definition, Art. 100-I

Electrical metallic tubing, 358.10(C)

Enameled equipment, 300.6(A)(1)

Intermediate metal conduit, 342.10(D)

Luminaires (lighting fixtures) in, 410.4(A)

Mounting of equipment, 300.6(C)

Rigid metal conduit, 344.10(D)

Rigid nonmetallic conduit, 352.10(D)

Switches, 404.4

Wires. *see also* Conductors; Cords; Fixture wires

In concrete footings, electrodes, 250.52(A)(3)

Wiring methods, Art. 300

Ducts, 300.21, 300.22

Exposed

Definition, Art. 100-I

General requirements for. *see* General requirements for
wiring methods

Planning, 90.8

Temporary. *see* Temporary installations

Types and materials, Chap. 3

Within sight from. *see* In sight from**Working space**

About electrical equipment, 110.26

Workmanlike installation, 110.12, 725.8, 760.8, 800.8,
820.24, 830.24

Committee Membership Classifications

The following classifications apply to Technical Committee members and represent their principal interest in the activity of a committee.

- M *Manufacturer:* A representative of a maker or marketer of a product, assembly, or system, or portion thereof, that is affected by the standard.
- U *User:* A representative of an entity that is subject to the provisions of the standard or that voluntarily uses the standard.
- I/M *Installer/Maintainer:* A representative of an entity that is in the business of installing or maintaining a product, assembly, or system affected by the standard.
- L *Labor:* A labor representative or employee concerned with safety in the workplace.
- R/T *Applied Research/Testing Laboratory:* A representative of an independent testing laboratory or independent applied research organization that promulgates and/or enforces standards.
- E *Enforcing Authority:* A representative of an agency or an organization that promulgates and/or enforces standards.
- I *Insurance:* A representative of an insurance company, broker, agent, bureau, or inspection agency.
- C *Consumer:* A person who is, or represents, the ultimate purchaser of a product, system, or service affected by the standard, but who is not included in the *User* classification.
- SE *Special Expert:* A person not representing any of the previous classifications, but who has special expertise in the scope of the standard or portion thereof.

NOTES

1. "Standard" connotes code, standard, recommended practice, or guide.
2. A representative includes an employee.
3. While these classifications will be used by the Standards Council to achieve a balance for Technical Committees, the Standards Council may determine that new classifications of members or unique interests need representation in order to foster the best possible committee deliberations on any project. In this connection, the Standards Council may make such appointments as it deems appropriate in the public interest, such as the classification of "Utilities" in the National Electrical Code Committee.
4. Representatives of subsidiaries of any group are generally considered to have the same classification as the parent organization.



ویدیو - انیمیشن های اطفاء، اعلام حریق، تهویه و تخلیه دود (رایگان)

برای مشاهده هر یک از ویدیوهای زیر کافیست بر روی عنوان آن آموزش کلیک نمایید تا به صفحه ویدیو و آموزش آن عنوان هدایت شوید.

انیمیشن ویدیو

• اطفاء حریق آبی

- [سیستم اطفاء لوله خشک اسپرینکلر](#)
- [سیستم اطفاء لوله تر اسپرینکلر](#)
- [سیستم اطفاء پیش عملگر](#)
- [سیستم اطفاء واترمیست](#)
- [سیستم اطفاء سیلابی](#)

• سیستم اطفاء فوم

• تجهیزات اطفاء حریق - تجهیزات هشدار دهنده

• تجهیزات اطفاء حریق - اسپرینکلر

• سیستم اطفاء آشپزخانه صنعتی

• سیستم اطفاء آبروسل

• سیستم اطفاء دستی

• سیستم اطفاء گازی

○ [سیستم اطفاء FM200 , NOVEC, Inert Gas \(IG\)](#)

○ [سیستم اطفاء CO₂](#)

• [سیستم تهویه و تخلیه دود](#)

• [سیستم اعلام حریق](#)

○ [آدرس پذیر](#)

○ [متعارف](#)





آموزش استاندارد

- [آموزش استاندارد NFPA 13](#)
- [آموزش استاندارد NFPA 14](#)
- [آموزش استاندارد NFPA 20](#)

آموزش نرم افزار

- [اتواسپرینک](#)
- [پایروسیم](#)
- [پت فایندر](#)

دانلود استاندارد

- [ترجمه استاندارد NFPA 30,14,13,10](#)
- [تمامی استانداردهای NFPA & FM](#)
- [ترجمه استاندارد NFPA 1037](#)

محصولات

- [اتواسپرینک ۲۰۱۳ و ۲۰۱۹ به زبان فارسی برای اولین بار در ایران](#)
- [آلارم کد ۲۰۱۹ به زبان فارسی برای اولین بار در ایران](#)
- [اطفا حریق آبی](#)
- [پایپنت \(ماژول اسپرینکلر\)](#)
- [کانتم](#)
- [اعلان حریق](#)

دوره‌های حضوری

- آموزش اتواسپرینک
- آموزش آلارم کد
- آموزش پایروسیم
- آموزش کانتم + اگزاست
- آموزش اطفا آبی + پمپ + بازدید از کارگاه
- آموزش اطفا گازی
- آموزش اطفا فوم
- آموزش مبحث سوم مقررات ملی
- آموزش اعلام حریق F&G
- آموزش اعلام حریق آدرس پذیر
- آموزش اعلام حریق متعارف
- دوره آمادگی آزمون آتش نشانی (برق، مکانیک، عمران، معماری)





دوره های آموزشی

ارائه تخفیف جهت خرید نرم افزارها

ارائه کد تخفیف جهت شرکت در دوره های آموزشی



EDUFIRE.IR

طراحی تهویه و تخلیه دود همراه با آموزش نرم افزار Contam کد آموزشی ۱۰۴	میانی و شناخت پمپ بوسترپمپ های آبرسانی و آتش نشانی به همراه بازدید از خط تولید کد آموزشی ۱۰۳	طراحی اعلام حریق Addressable Conventional کد آموزشی ۱۰۲	طراحی اطفاء حریق آبی با نرم افزار AutoSPRINKY۰۱۹ کد آموزشی ۱۰۱
۱۶ ساعت	۱۶ ساعت	۱۶ ساعت	۱۶ ساعت
طراحی اطفاء حریق گازی FM200 & NOVEC CO ₂ کد آموزشی ۱۰۸	طراحی اطفاء حریق و آشنایی با ضوابط سازمان آتش نشانی کد آموزشی ۱۰۷	طراحی اطفاء حریق فوم کد آموزشی ۱۰۶	طراحی سیستم اعلان آدرس پذیر همراه با آموزش نرم افزار AlarmCAD کد آموزشی ۱۰۵
۱۶ ساعت	۱۶ ساعت	۱۶ ساعت	۱۶ ساعت
طراحی استخر، سونا و جگوزی کد آموزشی ۱۱۲	آمادگی آزمون آتش نشانی مکانیک - برق عمران - معماری کد آموزشی ۱۱۱	طراحی با نرم افزار Pyrosim کد آموزشی ۱۱۰	آموزش مبحث سوم مقررات ملی ساختمان کد آموزشی ۱۰۹
۱۶ ساعت	۱۶ ساعت	۱۶ ساعت	۳۲ ساعت



آموزشگاه ادوفایر
EDUFIRE

All **NFPA & FM** STANDARDS

 **EDUFIRE_NFPA**

 **EDUFIRE.IR**

 **Latest Version**

FREE

  
EDUFIRE.IR

