

CHAPTER 54

FIRE AND SMOKE CONTROL

<i>Balanced Approach to Fire Protection</i> .....	54.1	<i>Shaft Pressurization</i> .....	54.8
<i>Fire Stopping at HVAC Penetrations</i> .....	54.2	<i>Pressurized Stairwells</i> .....	54.9
<i>Fire and Smoke Dampers</i> .....	54.2	<i>Pressurized Elevators</i> .....	54.13
<i>Smoke Exhaust Fans</i> .....	54.3	<i>Zoned Smoke Control</i> .....	54.16
<i>Design Weather Data</i> .....	54.3	<i>Atrium Smoke Control</i> .....	54.17
<i>Smoke Movement</i> .....	54.3	<i>Tenability Systems</i> .....	54.23
<i>Methods Used to Control Smoke</i> .....	54.5	<i>Commissioning and Testing</i> .....	54.24
<i>Smoke Feedback</i> .....	54.7	<i>Extraordinary Incidents</i> .....	54.24
<i>Pressurization System Design</i> .....	54.7	<i>Symbols</i> .....	54.25

**S**MOKE, which causes the most deaths in fires, consists of air-borne solid and liquid particles and gases produced when a material undergoes pyrolysis or combustion, together with air that is entrained or otherwise mixed into the mass. In building fires, smoke often flows to locations remote from the fire, threatening life and damaging property. Stairwells and elevators frequently fill with smoke, thereby blocking or inhibiting evacuation.

The idea of using pressurization to prevent smoke infiltration of stairwells began to attract attention in the late 1960s. This concept was followed by the idea of the pressure sandwich (i.e., venting or exhausting the fire floor and pressurizing the surrounding floors). Frequently, a building’s HVAC system is used for this purpose. This chapter focuses on smoke control systems in buildings, including the relationship between smoke control and HVAC. A **smoke control system** is an engineered system that modifies smoke movement for the protection of building occupants, firefighters and property. The focus of code-mandated smoke control is life safety.

For an extensive technical treatment of smoke control and related topics, see the *Handbook of Smoke Control Engineering* (Klote et al. 2012), referred to in this chapter as the *Smoke Control Handbook*. For those interested in the theoretical foundations of smoke control, the *Smoke Control Handbook* includes an appendix of derivations of equations.

National Fire Protection Association (NFPA) *Standard 92* provides information about smoke control systems for buildings. For further information about heat and smoke venting for large industrial and storage buildings, see NFPA *Standard 204*.

The objective of fire safety is to provide some degree of protection for a building’s occupants, the building and property inside it, and neighboring buildings. Various forms of analysis have been used to quantify protection. Specific life safety objectives differ with occupancy; for example, nursing homes have different requirements than office buildings do.

Two basic approaches to fire protection are (1) to prevent fire ignition and (2) to manage fire effects. **Figure 1** shows a decision tree for fire protection. Building occupants and managers have the primary role in preventing fire ignition, though the building design team may incorporate features into the building to support this effort. Because it is impossible to prevent fire ignition completely, managing fire’s effects is significant in fire protection design. Examples include compartmentation, suppression, control of construction materials, exit systems, and smoke control. The *SFPE Handbook of Fire Protection Engineering* (SFPE 2016) contains detailed fire safety information.

The preparation of this chapter is assigned to TC 5.6, Control of Fire and Smoke.

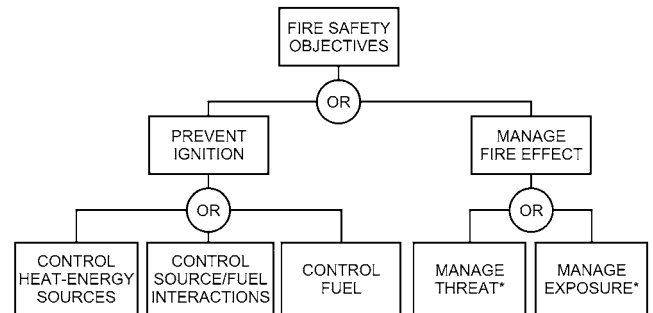

\*Note: Smoke control is one of many fire protection tools that can be used to help manage the threat and exposure of fire.

**Fig. 1 Simplified Fire Protection Decision Tree**

Historically, fire safety professionals have considered the HVAC system a potentially dangerous penetration of natural building membranes (walls, floors, etc.) that can readily transport smoke and fire. For this reason, HVAC has traditionally been shut down when fire is discovered; this prevents fans from forcing smoke flow, but does not prevent ducted smoke movement caused by buoyancy, stack effect, or wind. Smoke control methods have been developed to address smoke movement; however, smoke control should be viewed as only one part of the overall building fire protection system.

**1. BALANCED APPROACH TO FIRE PROTECTION**

Many codes and standards seek a balanced approach to fire protection consisting of detection, suppression, and occupant protection. This approach results in highly reliable protection from the threat of fire. A NFPA study (Ahrens 2017) based on data from the National Fire Incident Reporting System provides reliability information for automatic sprinkler protection. The report states “In fires considered large enough to activate the sprinkler, sprinklers operated 92% of the time. Sprinklers were effective in controlling the fire in 96% of the fires in which they operated. Taken together, sprinklers both operated and were effective in 88% of the fires large enough to operate them.” This means that sprinklers have an overall reliability of 88% (or, put another way, an overall failure rate of 12%).

In general, such reliability data are not available for other fire safety features such as detectors, fire alarms, fire-resistant construction, fire stopping, or smoke control. Smoke control is particularly important because it provides protection for occupants from the threat of smoke. It is generally recognized that fires that have resulted in loss of life have had failures of one or more fire

safety features. With the balanced approach, if one or more fire safety feature fails, other features will continue to provide a level of protection, thereby providing greater reliability of fire protection than any single system.

## 2. FIRE STOPPING AT HVAC PENETRATIONS

Although most of this chapter discusses smoke control, fire management at HVAC penetrations is also a concern. Fire-rated assemblies (e.g., floor or walls) keep the fire in a given area for a specific period. However, fire can easily pass through openings for plumbing, HVAC ductwork, communication cables, or other services. Therefore, fire stop systems are installed to maintain the rating of the fire-rated assembly. The rating of a fire stop system depends on the number, size, and type of penetrations, and the construction assembly in which it is installed.

Performance of the entire fire stop system, which includes the construction assembly with its penetrations, is tested under fire conditions by recognized independent testing laboratories. ASTM *Standard* E814 and UL *Standard* 1479 describe ways to determine performance of **through-penetration fire stopping (TPFS)**.

TPFS is required by building codes under certain circumstances for specific construction types and occupancies. In the United States, the model building codes require that most penetrations pass ASTM *Standard* E814 testing. TPFS classifications are published by testing laboratories. Each classification is proprietary, and each applies to use with a specific set of conditions, so numerous types are usually required on any given project.

The construction manager and general contractor, not the architects and engineers, make work assignments. Sometimes they assign fire stopping to the discipline making the penetration; other times, they assign it to a specialty fire-stopping subcontractor. The Construction Specifications Institute (CSI 2018) assigns fire-stopping specifications to Division 7, Thermal and Moisture Protection, which

- Encourages continuity of fire-stopping products on the project by consolidating their requirements (e.g., TPFS, expansion joint fire stopping, floor-to-wall fire stopping, etc.)
- Maintains flexibility of work assignments for the general contractor and construction engineer
- Encourages prebid discussions between the contractor and subcontractors regarding appropriate work assignments

## 3. FIRE AND SMOKE DAMPERS

Dampers are used for one or more of the following purposes: (1) balancing flow by adjusting airflow in HVAC system ducts, (2) controlling flow (for HVAC purposes), (3) resisting passage of fire (**fire dampers**), (4) resisting heat transfer (**ceiling radiation dampers**),

and (5) resisting passage of smoke (**smoke dampers**). Dampers that are intended to resist the passage of both fire and smoke are called **combination fire and smoke dampers**. All dampers should be installed in accordance with manufacturer's recommendations. For more detailed information about dampers, including pressure losses, flow characteristics, actuators, installation, and balancing, see Felker and Felker (2009).

The UL *Standard* 555 series (555, 555S, and 555C) includes reliability testing provisions for each type of damper, the heat-responsive device, and the actuator (if used). Among the tests are cycling (20 000 full cycles for two-position dampers and 100 000 cycles for modulating dampers), structural integrity, salt spray for accelerated lifespan testing, hose stream spray, elevated temperatures, and leakage.

### Fire Dampers

Fire dampers are intended to prevent the spread of flames from one part of the building to another through the ductwork. They are not expected to prevent airflow between building spaces, because gaps of up to 9.5 mm are allowed for operating clearances. Fire dampers are rated to indicate the time they can be exposed to flames and still maintain their integrity, with typical ratings of 3 h, 1.5 h, 1 h, and less than 1 h. Fire dampers are two-position devices (open or closed), and are usually of either the multiblade (**Figure 2**) or curtain design (**Figure 3**). Most multiblade fire dampers are held open by a fusible link and are spring loaded. In a fire, hot gases cause this link to come apart so that the spring makes the blades slam shut. Some applications use other heat-responsive devices in place of fusible links. Typically, curtain dampers are also held open by a fusible link that comes apart when heated. Vertical static curtain dampers often rely on gravity to make the blades close off the opening, but horizontal (ceiling) and all dynamic curtain dampers must have spring closure. Dynamic dampers are for applications where the damper may be required to close against airflow, such as an HVAC system that remains operational for smoke control purposes. In the United States, fire dampers are usually made and labeled in accordance with UL *Standard* 555. This standard addresses fire dampers intended for use (1) where air ducts penetrate or terminate at openings in walls or partitions, (2) in air transfer openings, and (3) where air ducts extend through floors.

### Ceiling Radiation Dampers

Ceiling radiation dampers are designed and tested to UL *Standard* 555C. These dampers prevent heat transfer; they have some resistance to fire and smoke, but are not tested for fire and smoke passage.

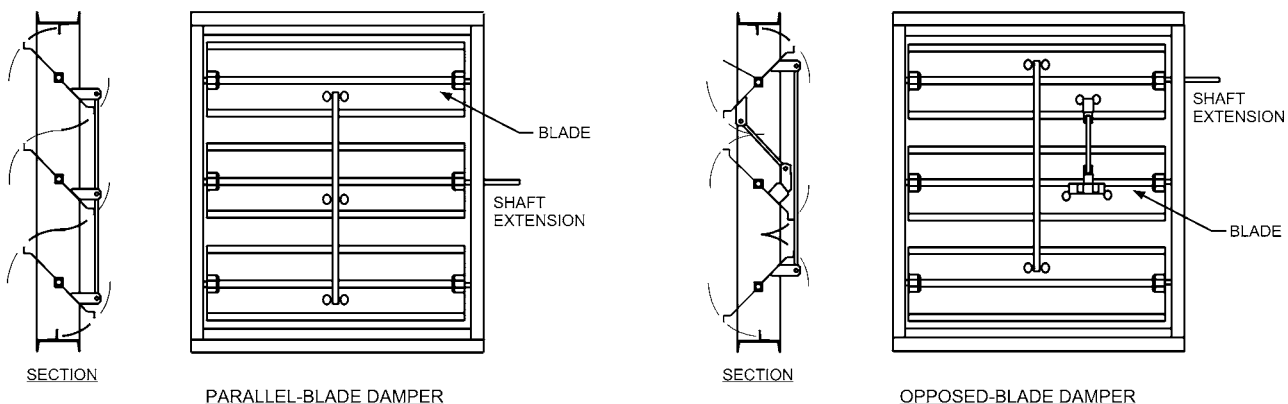

Fig. 2 Multiblade Dampers

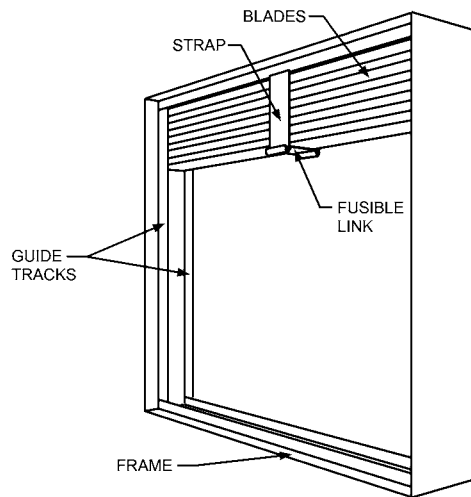

Fig. 3 Curtain Fire Damper

### Smoke Dampers

Smoke dampers are intended to seal tightly to prevent the spread of smoke from one part of the building to another through the ductwork, and to allow an engineered smoke control system to build up pressures across zone boundaries. A smoke damper is not required to withstand high temperature and will not prevent a fire from spreading. Smoke dampers are of the multiblade design (Figure 2), and may be listed for either two-position (open and closed) or modulating service. Smoke dampers listed for modulating service can be used as combination smoke and HVAC dampers. In the United States, smoke dampers are usually made and classified for leakage in accordance with UL Standard 555S. This standard includes construction requirements; air leakage tests; and endurance tests of cycling, temperature degradation, salt-spray exposure, and operation under airflow. Combination fire and smoke dampers comply with the dynamic fire damper requirements of UL Standard 555 and with the smoke damper requirements of UL Standard 555S.

### Corridor Dampers

Corridor dampers are combination fire and smoke dampers that are tested for horizontal installation in ceilings. They have sleeves designed for this application and allow use of front grilles for access to the damper and actuator. Corridor dampers need to be tested to UL Standards 555 and 555S for 1 h at 0.76 m/s.

## 4. SMOKE EXHAUST FANS

Typically, smoke control systems for buildings are designed to avoid the need for operation at elevated temperatures. For zoned smoke control systems, usually the zone being exhausted is much larger than the fire space, and this limits the gas temperature at the exhaust fan. For atrium smoke control systems, air is entrained in the smoke plume that rises above the fire, and this entrained air reduces the temperature of the smoke exhaust.

ASHRAE Standard 149 establishes uniform methods of laboratory testing and test documentation for fans used to exhaust smoke in smoke control systems.

## 5. DESIGN WEATHER DATA

The performance of smoke control systems can depend on outdoor temperature and wind. Chapter 2 of the *Smoke Control Handbook* lists design climatological data (winter and summer temperatures, wind speed, standard barometric pressure) for design of

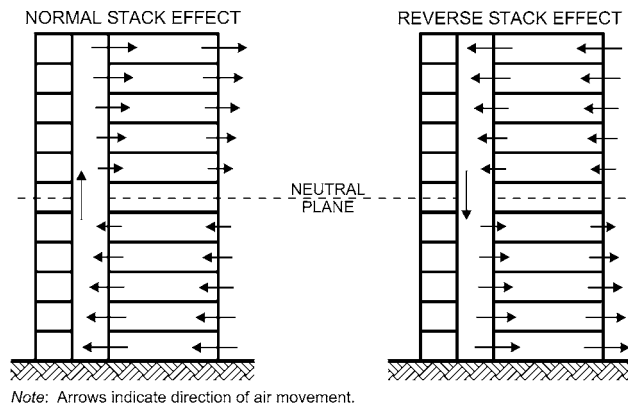

Note: Arrows indicate direction of air movement.

Fig. 4 Air Movement Caused by Normal and Reverse Stack Effect

smoke control systems for many locations in the United States, Canada, and other countries.

Wind is measured at weather stations, which are often at airports. Because local terrain has a significant effect on wind, wind speeds at project sites are usually very different from those measured at neighboring weather stations. For information about adjusting design wind speed to a project site, see Chapter 3 of the *Smoke Control Handbook* and Chapter 24 of the 2017 *ASHRAE Handbook—Fundamentals*.

## 6. SMOKE MOVEMENT

A smoke control system needs to be designed so that it is not overpowered by the driving forces that cause smoke movement: stack effect, buoyancy, expansion, wind, forced ventilation, and elevator piston effect. In a building fire, smoke is usually moved by a combination of these forces.

### Stack Effect

It is common to have an upward flow of air in building shafts during winter. These shafts include stairwells, elevator shafts, dumbwaiters, and mechanical shafts. The upward flow is caused by the buoyancy of warm air relative to the cold outdoor air. This upward flow is similar to the upward flow in smoke stacks, and it is from this analogy that the upward flow in shafts got the name stack effect. In summer, flow in shafts is downward. Upward flow in shafts is called **normal stack effect**, and downward flow is called **reverse stack effect**.

Figure 4 shows both kinds of stack effect. In normal stack effect, air flows into the building below the neutral plane, flows up building shafts, and out of the building above the neutral plane. The neutral plane is a horizontal plane where pressure inside the shaft equals outdoor pressure, and is often near the midheight of a building.

At standard atmospheric pressure, the pressure difference caused by either normal or reverse stack effect is expressed as

$$\Delta p_{SO} = 3460 \left( \frac{1}{T_O} - \frac{1}{T_S} \right) z \quad (1)$$

where

$$\begin{aligned} \Delta p_{SO} &= \text{pressure difference from shaft to outdoors, Pa} \\ T_S &= \text{absolute temperature of shaft, K} \\ T_O &= \text{absolute temperature of outdoors K} \\ z &= \text{distance above neutral plane, m} \end{aligned}$$

Figure 5 diagrams the pressure difference between a building shaft and the outdoors. A positive pressure difference indicates that shaft pressure is higher than the outdoor pressure, and a negative pressure difference indicates the opposite. For a building 60 m tall

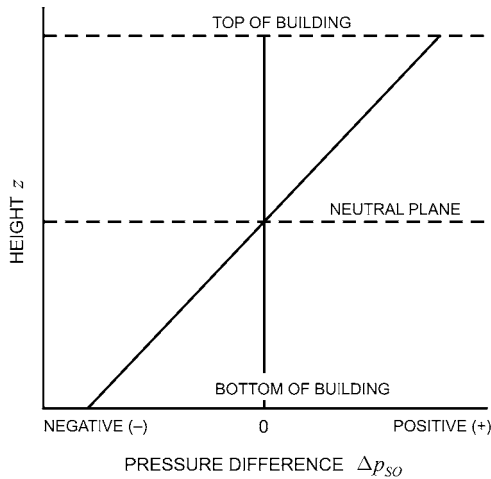

**Fig. 5 Pressure Difference Between Building Shaft and Outdoors Caused by Normal Stack Effect**

with a neutral plane at midheight, an outdoor temperature of  $-18^{\circ}\text{C}$  (255 K), and an indoor temperature of  $21^{\circ}\text{C}$  (294 K), the maximum pressure difference from stack effect is 54 Pa. This means that, at the top of the building, pressure inside a shaft is 54 Pa greater than the outdoor pressure. At the base of the building, pressure inside a shaft is 54 Pa lower than the outdoor pressure.

Smoke movement from a building fire can be dominated by stack effect. In a building with normal stack effect, the existing air currents (as shown in Figure 4) can move smoke considerable distances from the fire origin. If the fire is below the neutral plane, smoke moves with building air into and up the shafts. This upward smoke flow is enhanced by buoyancy forces from the smoke temperature. Once above the neutral plane, smoke flows from the shafts into the upper floors of the building. If leakage between floors is negligible, floors below the neutral plane (except the fire floor) remain relatively smoke free until more smoke is produced than can be handled by stack effect flows.

Smoke from a fire located above the neutral plane is carried by building airflow to the outdoors through exterior openings in the building. If leakage between floors is negligible, all floors other than the fire floor remain relatively smoke free until more smoke is produced than can be handled by stack effect flows. When leakage between floors is considerable, smoke flows to the floor above the fire floor.

Air currents caused by reverse stack effect (see Figure 4) tend to move relatively cool smoke down. In the case of hot smoke, buoyancy forces can cause smoke to flow upward, even during reverse stack effect conditions.

**Caution:** It is a myth that the pressure difference caused by stack effect is nearly proportional to the temperature difference between the building and the outdoors. Instead, this pressure difference is nearly proportional to the temperature difference between a shaft and the outdoors. Looking at Figure 4, it is easy to see how the shaft and building temperatures might be considered identical. Often, they are the same. However, shafts that have one or more walls on the outside of the building tend to be relatively cold in winter and warm in summer, and this can have a major influence on stack effect.

For a building with shafts of various heights and different shaft temperatures, the flows become very complicated and would not resemble those in Figure 4. Each shaft could have its own neutral plane with respect to the outdoors, and may have more than one neutral plane. Equation (1) is not applicable for such complicated buildings, but the flows and pressures in such buildings can be analyzed

by a network flow model such as CONTAM (see the section on Computer Analysis).

## Buoyancy

High-temperature smoke has buoyancy because of its reduced density. At sea level, the pressure difference between a fire compartment and its surroundings can be expressed as follows:

$$\Delta p_{FS} = 3460z \left( \frac{1}{T_S} - \frac{1}{T_F} \right) \quad (2)$$

where

$\Delta p_{FS}$  = pressure difference from fire compartment to surroundings, Pa

$z$  = distance above neutral plane, m

$T_S$  = absolute temperature of surroundings, K

$T_F$  = average absolute temperature of fire compartment, K

The neutral plane is the plane of equal hydrostatic pressure between the fire compartment and its surroundings. For a fire with a fire compartment temperature at  $800^{\circ}\text{C}$  (1073 K), the pressure difference 1.5 m above the neutral plane is 13 Pa. Fang (1980) studied pressures caused by room fires during a series of full-scale fire tests and found a maximum pressure difference of 16 Pa across the burn room wall at the ceiling. Much larger pressure differences are possible for tall fire compartments, where the distance  $z$  from the neutral plane can be larger.

In sprinkler-controlled fires, the temperature in the fire room remains at that of the surroundings except for a short time before sprinkler activation. Sprinklers are activated by the **ceiling jet**, which is a layer of hot gas under the ceiling. The ceiling jet's maximum temperature depends on the fire's location, activation temperature of the sprinkler, and thermal lag of the sprinkler's heat-responsive element. For most residential and commercial applications, the ceiling jet is between  $80$  and  $150^{\circ}\text{C}$ . In Equation (2),  $T_F$  is the average temperature of the fire compartment.

For a sprinkler-controlled fire,

$$T_F = \frac{T_S(H - H_J) + T_J H_J}{H} \quad (3)$$

where

$T_F$  = average absolute temperature of fire compartment, K

$T_S$  = absolute temperature of surroundings, K

$H$  = floor-to-ceiling height, m

$H_J$  = thickness of ceiling jet, m

$T_J$  = absolute temperature of ceiling jet, K

**Example 1.** For  $H = 2.5$  m,  $H_J = 0.1$  m,  $T_S = 20 + 273 = 293$  K, and  $T_J = 150 + 273 = 423$  K, the average absolute temperature of the fire compartment is

$$T_F = [293(2.5 - 0.1) + 423 \times 0.1] / 2.5 = 298 \text{ K or } 25^{\circ}\text{C}$$

In Equation (2), this value of  $T_F$  and  $z$  of 1.5 m results in a pressure difference of 0.5 Pa, which is insignificant for smoke control applications.

## Expansion

Energy released by a fire can also move smoke by expansion. In a fire compartment with only one opening to the building, building air flows in, and hot smoke flows out. Neglecting the added mass of the fuel, which is small compared to airflow, the ratio of volumetric flows can be expressed as a ratio of absolute temperatures:

$$\frac{V_{out}}{V_{in}} = \frac{T_{out}}{T_{in}} \quad (4)$$

where

$V_{out}$  = volumetric flow rate of smoke out of fire compartment,  $\text{m}^3/\text{s}$

$V_{in}$  = volumetric flow rate of air into fire compartment,  $\text{m}^3/\text{s}$

$T_{out}$  = absolute temperature of smoke leaving fire compartment, K  
 $T_{in}$  = absolute temperature of air entering fire compartment, K

For smoke at 700°C (973 K) and entering air at 20°C (293 K), the ratio of volumetric flows is 3.32. Note that absolute temperatures are used in the calculation. In such a case, if air enters the compartment at 1.5 m<sup>3</sup>/s, then smoke flows out at 5.0 m<sup>3</sup>/s, with the gas expanding to more than three times its original volume.

For a fire compartment with open doors or windows, the pressure difference across these openings caused by expansion is negligible. However, for a tightly sealed fire compartment, the pressure differences from expansion may be important.

**Wind**

In many instances, wind can have a pronounced effect on smoke movement within a building. The pressure that wind exerts on a wall is

$$p_w = \frac{1}{2} C_w \rho_o U_H^2 \tag{5}$$

where

- $p_w$  = wind pressure, Pa
- $C_w$  = pressure coefficient
- $\rho_o$  = outdoor air density, kg/m<sup>3</sup>
- $U_H$  = velocity at wall height  $H$ , m/s

The pressure coefficient  $C_w$  depends on wind direction, building geometry, and local obstructions to the wind. The pressure coefficients are in the range of -0.8 to 0.8, with positive values for windward walls and negative for leeward walls.

Frequently, a window breaks in the fire compartment. If the window is on the leeward side of the building, the negative pressure caused by the wind vents the smoke from the fire compartment. This reduces smoke movement throughout the building. However, if the broken window is on the windward side, wind forces the smoke throughout the fire floor and to other floors, which endangers the lives of building occupants and hampers firefighting. Wind-induced pressure in this situation can be large and can dominate air movement throughout the building. For more detailed information about wind and smoke control, see Chapter 3 of the *Smoke Control Handbook*.

**Forced Ventilation**

Modern HVAC systems are built of materials intended to withstand fires, and either shut down in the event of a fire or go into a smoke control mode of operation. For details on the latter approach, see the section on Zoned Smoke Control.

**Elevator Piston Effect**

The transient pressures and flows produced when an elevator car moves in a shaft are called **piston effect**, and can pull smoke into a normally pressurized elevator lobby or elevator shaft. For a validated analysis of piston effect, see Klote (1988) and Klote and Tamura (1986, 1987).

In the absence of stack effect or other driving forces, pressure above a rising elevator car is higher than that below the car. For this upward-moving car, there is airflow into the shaft below the car, and airflow out of the shaft above the car. When the car passes a floor, the pressure difference across the elevator door on that floor suddenly drops and then increases. For elevators with lobbies that have closed doors (enclosed lobbies), the pressure difference across the closed lobby doors reacts in a similar way to elevator car motion.

For a car traveling from the bottom to the top of the shaft, the largest value of pressure difference from piston effect is at the top of the shaft; for a car traveling from the top to the bottom, the largest value is at the bottom of the shaft. This largest value of pressure difference (called the piston effect) for an elevator with enclosed lobbies is

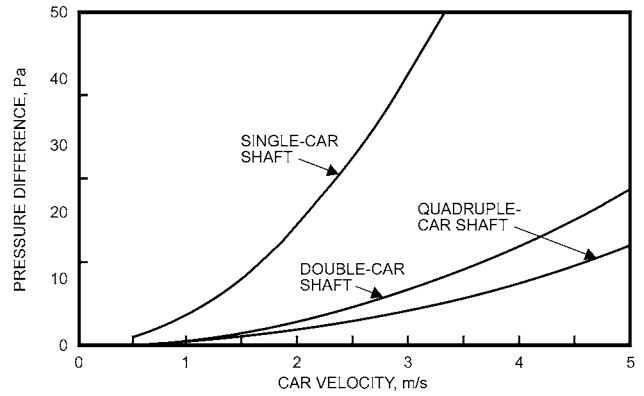

**Fig. 6** Calculated Upper Limit of Piston Effect Across Elevator Lobby Doors.

$$\Delta p_{u, si} = \frac{\rho}{2} \left( \frac{A_s A_e U}{A_a A_{lr} C_c} \right)^2 \tag{6}$$

where

- $\Delta p_{u, si}$  = upper limit pressure difference from shaft to building, Pa
- $\rho$  = air density in hoistway, kg/m<sup>3</sup>
- $A_s$  = cross-sectional area of shaft, m<sup>2</sup>
- $A_e$  = effective area, m<sup>2</sup>
- $U$  = elevator car velocity, m/s
- $A_a$  = free area around elevator car, m<sup>2</sup>
- $A_{lr}$  = leakage area between building and lobby, m<sup>2</sup>
- $C_c$  = flow coefficient for flow around car

The flow coefficient  $C_c$  was determined experimentally at about 0.94 for a multiple-car hoistway and 0.83 for a single-car hoistway. The free area around the elevator car is the cross-sectional area of the shaft less the cross-sectional area of the car. Effective areas are discussed in the section on Height Limit.

Figure 6 shows the upper limit of piston effect from the lobby to the building for normal elevator car velocities from 1 to 5 m/s. All elevator velocities are in this range except for those in extremely tall buildings. Figure 6 shows that piston effect is greatest for single-car shafts, and elevators that travel at relatively high velocities in single-car shafts have the potential for piston effect that may adversely affect smoke control performance.

**7. METHODS USED TO CONTROL SMOKE**

In this chapter, smoke control includes all methods that can be used singly or in combination to modify smoke movement to protect occupants or firefighters or reduce property damage. These methods are (1) compartmentation, (2) dilution, (3) pressurization, (4) airflow, and (5) buoyancy. These mechanisms are discussed in the following sections.

**Compartmentation**

Barriers that can remain effective throughout a fire exposure have long been used to protect against fire spread. In this approach, walls, partitions, floors, doors, and other barriers provide some level of smoke protection to spaces remote from the fire. Passive smoke control consists of using barriers alone (or without pressurization). Using compartmentation with pressurization is discussed in the section on Pressurization (Smoke Control). Passive smoke control systems can be analyzed with the goal of providing a tenable environment at specific locations during a fire. For more information, see the section on Tenability Systems. Many codes, such as the *Life Safety Code*® (NFPA 2012) and the *International Building Code*® (ICC 2012), provide specific criteria for construction of passive smoke barriers (including doors) and their smoke dampers. The

extent to which smoke leaks through such barriers depends on the size and shape of the leakage paths in the barriers and the pressure difference across the paths.

### Dilution Remote from Fire

Smoke dilution is sometimes referred to as **smoke purging**, **smoke removal**, **smoke exhaust**, or **smoke extraction**. Dilution can be used to maintain acceptable gas and particulate concentrations in a compartment subject to smoke infiltration from an adjacent space. It can be effective if the rate of smoke leakage is small compared to either the total volume of the safeguarded space or the rate of purging air supplied to and removed from the space. Also, dilution can be beneficial to the fire service for removing smoke after a fire has been extinguished. Sometimes, when doors are opened, smoke flows into areas intended to be protected. Ideally, the doors are only open for short periods during evacuation. Smoke that has entered spaces remote from the fire can be purged by supplying outdoor air to dilute the smoke.

The following is a simple analysis of smoke dilution for spaces in which there is no fire. At time zero ( $t = 0$ ), a compartment is considered contaminated with some concentration of smoke and no more smoke flows into the compartment or is generated in it. Further, the contaminant is considered to be uniformly distributed throughout the space. The concentration of contaminant in the space can be expressed as

$$\frac{C}{C_0} = e^{-at} \quad (7)$$

and the dilution rate can be calculated from

$$a = \frac{1}{t} \ln \left( \frac{C_0}{C} \right) \quad (8)$$

where

- $C$  = concentration of contaminant at time  $t$
- $C_0$  = initial concentration of contaminant
- $e$  = base of natural logarithm (approximately 2.718)
- $a$  = dilution rate, air changes per minute
- $t$  = time after smoke stops entering space or smoke production has stopped, min

Concentrations  $C_0$  and  $C$  need to be expressed in the same units, but can be any units appropriate for the particular contaminant being considered.

In reality, it is impossible to ensure that the concentration of the contaminant is uniform throughout the compartment. Because of buoyancy, it is likely that concentrations are higher near the ceiling. Therefore, exhausting smoke near the ceiling and supplying air near the floor probably dilutes smoke even more quickly than indicated by Equation (8). Supply air should be free or nearly free of smoke, as discussed in the Smoke Feedback section.

**Example 2.** A space is isolated from a fire by smoke barriers and self-closing doors, so that no smoke enters the compartment when the doors are closed. When a door is opened, smoke flows through the open doorway into the space. If the door is closed when the contaminant in the space is 20% of the burn room concentration, what dilution rate is required to reduce the concentration to 1% of that in the burn room in 6 min?

**Solution.** Time  $t = 6$  min and  $C_0/C = 20$ . From Equation (8), the dilution rate is about 0.5 air changes per minute, or 30 air changes per hour.

**Caution About Dilution near Fire:** Some people have unrealistic expectations about what dilution can accomplish in the fire space. Neither theoretical nor experimental evidence indicates that using a building's HVAC system for smoke dilution significantly improves tenable conditions in a fire space. The exception is an unusual space where the fuel is such that fire size cannot grow above a specific limit, such as in some tunnels and underground transit situations.

Because HVAC systems promote a considerable degree of air mixing in the spaces they serve and because very large quantities of smoke can be produced by building fires, it is generally believed that smoke dilution by an HVAC system in the fire space does not improve tenable conditions in that space. Thus, any attempt to improve hazard conditions in the fire space, or in spaces connected to the fire space by large openings, with smoke purging will be ineffective.

### Pressurization

Many smoke control systems use mechanical fans to control smoke by pressurization. Pressure difference across a barrier can control smoke movement by preventing smoke on the low-pressure side of the barrier from migrating to the high-pressure side. Pressurization can control smoke from a fire remote from a barrier, or from a very large fire located next to a barrier (Figure 7).

Frequently, in field tests of smoke control systems, pressure differences across partitions or closed doors fluctuate by 5 Pa. These fluctuations are generally attributed to wind, although they could have been caused by the HVAC system or some other source. To control smoke movement, the pressure difference produced by a smoke control system needs to be large enough to overcome pressure fluctuations, stack effect, smoke buoyancy, and wind pressure, but not so large that the door is difficult to open. Pressurization of smoke control systems is discussed in the section on Pressurization System Design.

### Opposed Airflow

Airflow can be used to control smoke flow in many applications, including buildings, rail tunnels, and highway tunnels, if the air velocity equals or exceeds the limiting velocity (Figure 8). For information about rail and highway tunnels, see Chapter 16. For control of smoke between an atrium and a communicating space, see NFPA Standard 92 and the limiting velocity equations in Chapter 15 of the *Smoke Control Handbook*.

Airflow smoke control is not used much in buildings because of the very large amounts of airflow needed, and (more importantly) because airflow can supply oxygen to the fire, which can result in catastrophic failure. Even full sprinkler protection does not completely eliminate this risk. For any application that uses the airflow approach, this failure mode needs to be addressed in the design analysis.

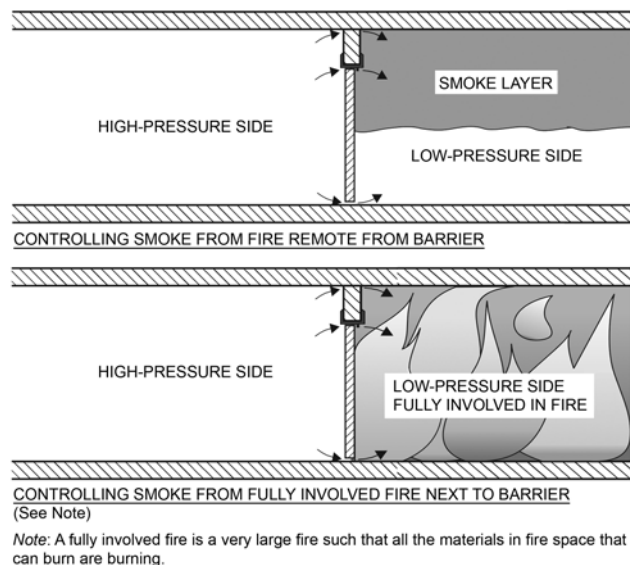

Fig. 7 Smoke Flow Controlled by Pressurization

## Buoyancy

Buoyancy of hot combustion gases is used for smoke control in large-volume spaces such as atriums. A smoke plume rises above the fire to form a smoke layer under the ceiling of the large volume space. The smoke plume entrains air from the surroundings. The mass flow of the plume increases with height, and the plume temperature decreases with height. Plume flow is the basis of atrium smoke control (see the section on Atrium Smoke Control).

## 8. SMOKE FEEDBACK

Smoke feedback occurs when smoke from an indoor fire flows outdoors and then either (1) is pulled into a smoke control supply fan or (2) flows into an atrium makeup air vent. To minimize the potential for smoke feedback, supply air intakes should be located away from the major openings from which smoke could leave a building, such as smoke control exhausts, heat and smoke vents, and open vents of elevator shafts. Smoke entering a building at a loading dock because of a large fire inside a truck should be evaluated. Considering the enormous number of possible fire scenarios and building designs, it is not possible to anticipate all the possible openings where smoke could leave a building.

Outdoor air intakes of smoke control systems should be located such that forces of wind and buoyancy minimize the potential for smoke feedback into supply air. An understanding of airflow around buildings can be helpful in minimizing the potential for smoke feedback. See Chapter 24 of the 2017 *ASHRAE Handbook—Fundamentals* for information about airflow around buildings.

**Caution:** using smoke detectors to automatically shut down smoke control supply fans is not recommended, because smoke detectors are extremely sensitive to small amounts of smoke that would not result in an untenable environment. This high sensitivity is important to provide early warning of fires, but it could shut down a smoke control system from a puff of smoke that would not be life threatening.

## 9. PRESSURIZATION SYSTEM DESIGN

The section has general information applicable to all pressurization smoke control systems. The common pressurization smoke control systems are pressurized stairwells, pressurized elevators, and zoned smoke control, which are discussed later. Supply air for pressurization smoke control systems should be free or nearly free of smoke as discussed in the section on smoke feedback.

### Door-Opening Forces

The pressure difference across a barrier must not result in door-opening forces that exceed the maximum values stipulated in codes. For example, in the *NFPA Life Safety Code*<sup>®</sup> (*NFPA Standard 101*), this maximum force is 133 N.

The force required to open a side-hinged swinging door is the sum of the forces to overcome the pressure difference across the door and to overcome the door closer. This can be expressed as

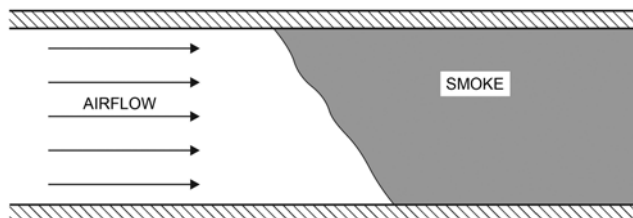

Note: Airflow can control smoke flow if air velocity is large enough.

Fig. 8 Opposed Airflow Controlling Smoke Flow

$$F = F_{dc} + \frac{WA\Delta p}{2(W-d)} \quad (9)$$

where

- $F$  = total door-opening force, N
- $F_{dc}$  = force to overcome door closer and other friction, N
- $W$  = door width, m
- $A$  = door area, m<sup>2</sup>
- $\Delta p$  = pressure difference, Pa
- $d$  = offset, m

The offset  $d$  is the distance between where the door-opening force is applied and the side of the door opposite the hinges (i.e., the latch side). For a lever handle, the door-opening force can be applied where the hand grasps the lever handle. For panic hardware, the door-opening force can be applied somewhere along the panic bar. For doors that do not stick to the door frame and have properly lubricated hinges,  $F_{dc}$  is the force to overcome the door closer. For more detailed information about door-opening forces, see Klote (2018).

**Example 3.** For a side-hinged swinging door 0.914 m wide by 2.13 m high with a door closer that requires 40 N of force, and a pressure difference across it of 87 Pa. The door-opening force is applied at a lever handle such that the offset is 76 mm. The door-opening force calculated from Equation (9) is 132 N.

### Flow and Pressure Difference

The primary equation used for analysis of pressurization smoke control systems is the orifice equation:

$$m = CA\sqrt{2\rho\Delta p} \quad (10)$$

Alternatively, Equation (10) can be expressed in terms of volumetric flow:

$$V = CA\sqrt{\frac{2\Delta p}{\rho}} \quad (11)$$

where

- $m$  = mass flow through the path, kg/s
- $C$  = flow coefficient
- $A$  = flow area (or leakage area), m<sup>2</sup>
- $\Delta p$  = pressure difference across path, Pa
- $V$  = volumetric flow, m<sup>3</sup>/s
- $\rho$  = gas density in path, kg/m<sup>3</sup>

Equations (10) and (11) are equivalent forms of the same orifice equation. Airflow paths need to be identified and evaluated in smoke control system design. Some leakage paths are obvious, such as cracks around closed doors, open doors, elevator doors, windows, and air transfer grilles. Construction cracks in building walls are less obvious but no less important.

The flow area of most large openings, such as open windows, can be calculated easily. However, flow areas of cracks are more difficult to evaluate. The area of these leakage paths depends on quality of work (e.g., how well a door is fitted or how weatherstripping is installed).

For many flow paths in buildings, a flow coefficient of 0.65 is used. The open doors of pressurized stairwells commonly have stationary vortices that reduce flow significantly (Cresci 1973; Klote and Bodart 1985). These vortices are thought to be caused by asymmetric flow from the stairs, and stationary vortices can be expected at many open doors in other locations of smoke control systems. For open doors in stairwells, the geometric area of the opening should be used for the flow area, with a flow coefficient of 0.35.

Typical leakage areas for walls and floors of commercial buildings are tabulated as area ratios in Table 1. These data are based from field tests performed by the National Research Council of Canada (Shaw et al. 1993; Tamura and Shaw 1976a, 1976b, 1978;

**Table 1 Typical Flow Areas of Walls and Floors of Commercial Buildings**

Construction Element	Wall Tightness	Area Ratio $A/A_W^*$
	$A/A_F^*$	
Exterior building walls (includes construction cracks and cracks around windows and doors)	Tight	$5.0 \times 10^{-5}$
	Average	$1.7 \times 10^{-4}$
	Loose	$3.5 \times 10^{-4}$
	Very Loose	$1.2 \times 10^{-3}$
Stairwell walls (includes construction cracks but not cracks around windows or doors)	Tight	$1.4 \times 10^{-5}$
	Average	$1.1 \times 10^{-4}$
	Loose	$3.5 \times 10^{-4}$
Elevator shaft walls (includes construction cracks but not cracks around doors)	Tight	$1.8 \times 10^{-4}$
	Average	$8.4 \times 10^{-4}$
	Loose	$1.8 \times 10^{-3}$
Floors (includes construction cracks and gaps around penetrations)	Tight	$6.6 \times 10^{-6}$
	Average	$5.2 \times 10^{-5}$
	Loose	$1.7 \times 10^{-4}$

\* $A$  = leakage area;  $A_W$  = wall area;  $A_F$  = floor area.

Tamura and Wilson 1966). Considerable leakage data through building components are also provided in Chapter 3 of the *Smoke Control Handbook*.

Both the maximum and minimum allowable pressure differences across the boundaries of smoke control should be considered. The term *acceptable pressurization* applies to a system that operates within the range of minimum to maximum allowable pressure differences. The maximum allowable pressure difference should not cause excessive door-opening forces.

The minimum allowable pressure difference intended to prevent smoke migration across a barrier of a smoke control system is generally stipulated by code. The smoke control system needs to be designed to maintain this minimum design pressure difference under likely conditions of wind, stack effect, or buoyancy of hot smoke. Pressure differences caused by wind and stack effect can be large in the event of a broken window or an open window or door in the fire compartment. (Windows exposed to the heat of a fire often break.) Evaluation of these pressure differences depends on evacuation time, rate of fire growth, building configuration, and the presence of a fire suppression system. The code-required minimum and maximum design pressure differences need to be used. For locations with no such code requirements, the values of NFPA *Standard 92* are suggested.

### Computer Analysis by Network Modeling

CONTAM (Dols and Polidoro 2016) is the de facto standard computer program for analyzing pressurization smoke control systems. It is a network model that simulates airflow and contaminant flow in buildings. Network modeling for smoke control dates back to the 1960s, but these early models were subject to numerical difficulties and data input was extremely cumbersome and time consuming. CONTAM has superior numerical routines and sophisticated data input, and can be downloaded from the NIST website ([www.nist.gov/el/energy-and-environment-division-73200/nist-multizone-modeling/download-contam](http://www.nist.gov/el/energy-and-environment-division-73200/nist-multizone-modeling/download-contam)) at no cost. Because CONTAM does not solve the energy equation, the user needs to input the temperatures of the spaces in the network.

Note that, when CONTAM is discussed in this chapter, other network models could be used instead. Network models represent a building by a network of spaces or nodes, each at a specific pressure and temperature. The stairwells and other shafts can be modeled by a vertical series of spaces, one for each floor. Air flows through leakage paths (e.g., doors or windows that may be opened or closed,

partitions, floors, exterior walls, roofs) from regions of high pressure to regions of low pressure. Airflow through a leakage path is a function of the pressure difference across the leakage path.

In network models, air from outside the building can be introduced by a pressurization system into any level of a shaft or into other building spaces. This allows simulating pressurization of a stairwell, elevator shaft, stairwell vestibule, and any other building space. In addition, any building space can be exhausted. This allows analysis of zoned smoke control systems where the fire zone is exhausted and other zones are pressurized. The pressures and flows throughout the building are obtained by solving conservation equations for the network. Analysis can include the driving forces of wind, the pressurization system, and indoor-to-outdoor temperature difference.

The primary purpose of network simulations is to determine whether a particular smoke control system in a particular building can be balanced such that it will perform as intended. Network models can simulate pressures and flows throughout very large and complicated building networks with high accuracy, although the results are approximations.

There are many flow paths in buildings, including gaps around closed doors, open doors, and construction cracks in walls, roof, and floors. These flow paths are approximated for a design analysis. However, the approximated results can be useful in identifying problems with specific smoke control systems, so the smoke control system or the building can be modified appropriately. These simulations can also provide information to help size system components such as supply fans, exhaust fans, and vents.

First-time users of CONTAM may be confused by its extensive capabilities, many of which are not usually used for smoke control analysis. Chapter 14 of the *Smoke Control Handbook* has CONTAM user information intended to help start using the software for analysis of smoke control systems that rely on pressurization. This information includes a section on speeding up data input.

## 10. SHAFT PRESSURIZATION

Stairwell pressurization and elevator pressurization are two kinds of shaft pressurization systems. Major factors that must be addressed in the design of these systems are building complexity and stack effect.

### Building Complexity

Building complexity is a major factor in shaft pressurization, and successful shaft pressurization can be challenging in complicated buildings. A simple building has floor plans that are nearly the same from floor to floor, whereas a complicated building's floor plans differ considerably from floor to floor. [Figure 9](#) shows examples of these buildings. Air leaving a pressurized shaft flows through the building to the outdoors, and flow paths to the outdoors differ by floor in complicated buildings. This results in varying pressure differences across pressurized shafts from floor to floor in complicated buildings, and can result in challenging shaft pressurization systems. Stairwell pressurization is usually straightforward for simple buildings, but elevator pressurization can be a challenge even in simple buildings. Systems that can be used to overcome these challenges are discussed in the sections on Pressurized Stairwells and Pressurized Elevators.

### Stack Effect

Sometimes engineers will say that a pressurized stairwell or elevator must be designed to account for stack effect. If the space is properly pressurized, there is no neutral plane, and all the flows are from the stairwell. Strictly speaking, then, there is no stack effect in the pressurized stairwell or elevator: what is meant is that the space



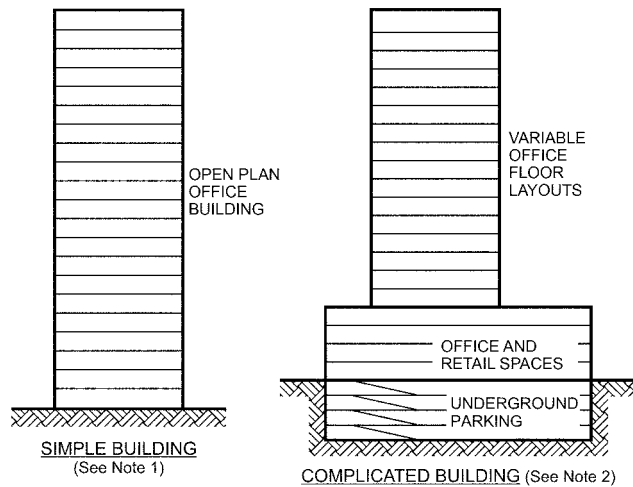

Notes:  
 1. For smoke control purposes, a simple building is one where floor plans are nearly the same from floor to floor.  
 2. For smoke control purposes, a complicated building is one where floor plans differ considerably from floor to floor.

Fig. 9 Examples of Simple and Complicated Buildings

must be designed to account for the temperature differences that cause stack effect.

**Caution:** It is a myth that stack effect is the major factor affecting stairwell and elevator pressurization. Although stack effect can be the major factor, it often is a minor factor for pressurized stairwells and elevators. Pressurization air for many stairwells and elevators is untreated outdoor air that is not heated or cooled. The temperature of these shafts is often nearly the same as the outdoor temperature, and the consequence of stack effect is significantly reduced as compared to shafts pressurized with air treated to the building temperature.

**Shaft Temperature.** When pressurization air is untreated, the shaft temperature can be expressed as

$$T_S = T_O + \eta(T_B - T_O) \tag{12}$$

where

- $T_S$  = temperature in stairwell, °C
- $T_O$  = temperature outdoors, °C
- $\eta$  = heat transfer factor
- $T_B$  = temperature in building, °C

There has been little research on the heat transfer factor, but it is believed to be in the range of 0.05 to 0.15. Without better data for a specific application, a heat transfer factor of 0.15 is suggested as conservative for the consequence of stack effect.

For untreated supply air, it takes a few minutes for the temperature in the shaft to stabilize near that of the outdoors. During this stabilization, excessive pressure differences could be produced. To prevent this, supply air can gradually be increased so that, when the shaft temperature is near that of the building, there is insufficient flow to cause excessive pressurization. If needed, temperature stabilization can be evaluated by a heat transfer analysis.

**Friction Losses in Shafts.** Pressure losses from friction in stairwells and elevator shafts can be significant when flow rates are high. CONTAM uses data from Achakji and Tamura (1988) and Tamura and Shaw (1976b) to calculate pressure loss in stairwells.

## 11. PRESSURIZED STAIRWELLS

Many pressurized stairwells have been designed and built to provide a tenable environment inside the stairwell in the event of a

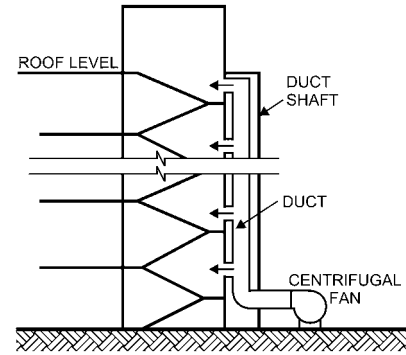

Fig. 10 Stairwell Pressurization by Multiple Injection with Fan Located at Ground Level

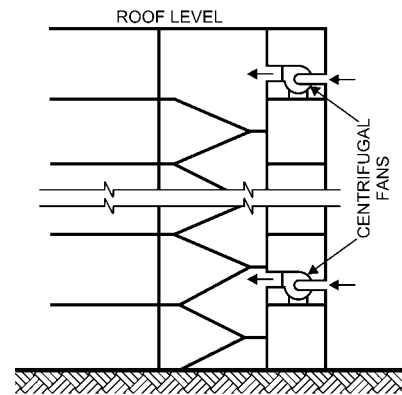

Fig. 11 Stairwell Pressurization by Multiple Injection with Multiple Fans

building fire. They also provide a smoke-free staging area for firefighters. On the fire floor, a pressurized stairwell is intended to provide a positive pressure difference across a closed stairwell door to prevent smoke infiltration. For stairwells in cold climates, designers should consider treating supply air to minimize the potential of freezing water in standpipes. Supply air for pressurized stairwells should be free or nearly free of smoke, as discussed in the Smoke Feedback section.

Air can be supplied to a pressurized stairwell at one or several locations. A single-injection system supplies pressurized air to the stairwell at one location, usually at the top. For tall stairwells, single-injection systems can fail when a few doors are open near the air supply injection point, especially in bottom-injection systems when a ground-level stairwell door is open.

Air can be supplied at multiple locations over the height of a tall stairwell. Figures 10 and 11 show two examples of **multiple-injection systems** that can be used to overcome the limitations of single-injection systems. Multiple-injection systems can use one or multiple fans. When one fan is used, air is supplied through a duct that is usually in a separate duct shaft. However, some systems eliminate the expense of a separate duct shaft by locating the supply duct in the stairwell itself. In such a case, ensure that the duct does not obstruct orderly building evacuation.

### Stairwell Compartmentation

Stairwell compartmentation, which is not often used, consists of dividing a stairwell into several sections consisting of five to ten stories each; each compartment has at least one supply air injection point. The compartments are separated by walls with normally

closed doors. The main advantage of compartmentation is that it allows acceptable pressurization of stairwells that are otherwise too tall for acceptable pressurization. A disadvantage is the increase in floor area needed for the walls and doors separating the stairwell sections. When the doors between compartments are open, the effect of compartmentation is lost. For this reason, compartmentation is inappropriate for densely populated buildings, where total building evacuation by stairwell is planned in the event of a fire.

### Vestibules

Pressurized stairwells with vestibules are occasionally used. The vestibules can be unpressurized, pressurized, ventilated, or both pressurized and ventilated. Vestibules provide an additional barrier around a stairwell, and can reduce the probability of an open-door connection existing between the stairwell and the building.

An evacuation analysis can determine the extent to which both vestibule doors are likely to be opened simultaneously. For densely populated buildings, it is expected that on many floors both vestibule doors would be opened simultaneously. Therefore, vestibules may provide little benefit of an extra barrier for densely populated buildings.

The algebraic equation method of analysis can be used to analyze a pressurized stairwell with an unpressurized vestibule. The pressure differences and flows of stairwell systems with any kind of vestibules, including those with openings to the outdoors and those with combinations of supply air and exhaust air, can be analyzed by CONTAM.

### System with Fire Floor Exhaust

This system can achieve acceptable pressurization of tall stairwells in very complicated buildings. A relatively small amount of air is supplied to the stairs, and the fire floor is exhausted such that acceptable pressurization is maintained on the fire floor where it is needed. Floors above and below the fire floor also may be exhausted. These systems are discussed further in the section on Zoned Smoke Control. When a CONTAM analysis shows that the code-mandated systems cannot or are likely not to be able to achieve successful pressurization, stairwell pressurization with fire floor exhaust could be a solution. The design analysis of these systems should include CONTAM simulations.

### Analysis of Pressurized Stairwells

Pressure differences across a stairwell tend to vary over the height of the stairwell. Figure 12 shows pressure profiles for pressurized stairwells in an idealized building (i.e., no vertical leakage through the floors and shafts, and leakage is the same from floor to floor) and in a more realistic building with vertical leakage through floors and an elevator shaft. This figure is for winter. When it is cold outdoors, the pressure differences tend to be less at the bottom of the stairwell than at the top. When it is hot outdoors, the trend is the opposite. For both winter and summer conditions, the pressure profile for an idealized building is a straight line.

The pressure profiles of stairs in real buildings depend on many factors, including (1) leakage values of the building components, (2) building floor plans, (3) size of elevator shaft or shafts and number of elevator doors, (4) presence or absence of elevator lobbies and vents, and (5) leakage through other shafts. There are many possible shapes for such pressure profiles in real buildings, but the complexities of airflow in buildings are such that specific patterns for pressure profiles are unknown.

For a building with vertical leakage, flows through the floors and shafts to some extent even out the highest and lowest pressure differences across the stairwell. The profile for a building with vertical leakage is bounded by the extremes of the pressure profile of the idealized building. This means that, other things being equal, the smallest pressure difference of the idealized analysis is less than that

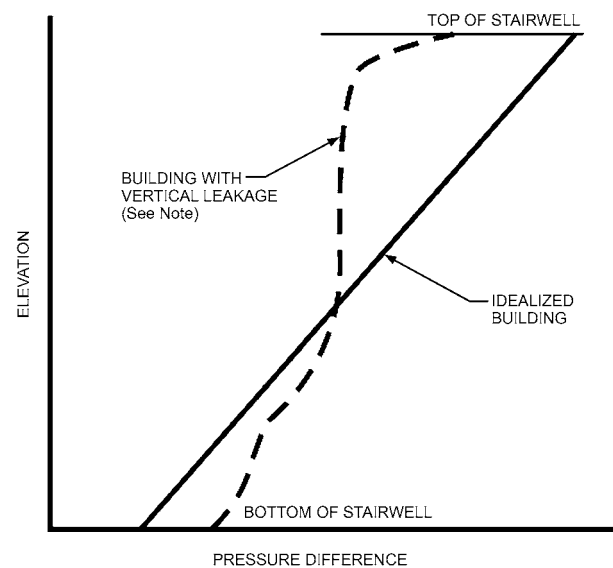

#### Notes:

1. The pressure difference is from the stairwell to the building across the stair door.
2. The shape of the curve for a building with vertical leakage depends on many factors, and the curve shown is only one of many possible shapes.

Fig. 12 Pressure Profile of a Pressurized Stairwell in Winter

Table 2 Stairwell Supply Air as Function of Leakage Classification

Stairwell Leakage Classification	Wall Leakage, $\text{m}^2/\text{m}^2$	Door Leakage, $\text{m}^2$	Supply Air, $\text{m}^3/(\text{s}\cdot\text{floor})$
Low	$1.4 \times 10^{-5}$	0.0075	0.04
Average	$1.1 \times 10^{-4}$	0.015	0.11
High	$3.5 \times 10^{-4}$	0.022	0.26

Note: The supply air listed was calculated by equation method to maintain a minimum pressure difference of 25 Pa.

of the realistic building, and that the largest pressure difference of the idealized analysis is more than that of the realistic building. This is why the algebraic equation method discussed in the section on Equations for Steady Smoke Exhaust is conservative.

An algebraic equation method of analysis pressurized stairwells is also presented in Chapter 10 of the *Smoke Control Handbook*. This algebraic equation method is based on (1) the idealized building, (2) flows calculated by the orifice equation, (3) effective areas, and (4) symmetry. It does not account for pressure losses in the stairwell from friction, but these losses tend to be small for stairwells when all stair doors are closed. CONTAM can analyze pressurized stairwells much more realistically than the algebraic equation method.

### Stairwell Fan Sizing

Some designers size fans for pressurized stairwells using their own rules of thumb, which are generally in the range of 0.14 to 0.26  $\text{m}^3/\text{s}$  per floor. Such estimates can be appropriate for simple buildings such as those discussed previously. The primary factor regarding the amount of pressurization air needed is stairwell leakage. Table 2 lists the supply air needed to pressurize stairwells as a function of leakage classification. If the fan is oversized, the amount of supply air can be adjusted during commissioning to achieve successful pressurization. Because of the high cost of replacing undersized fans (including electrical wiring), rules of thumb chosen by designers usually incorporate an allowance for leakier construction than actually anticipated.

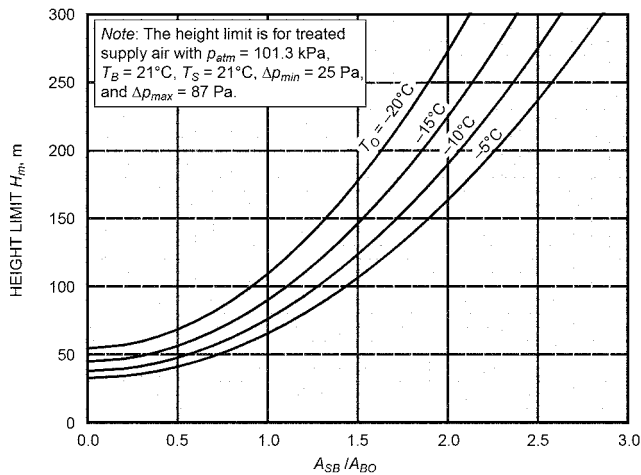

Fig. 13 Height Limit with Treated Supply Air in Winter

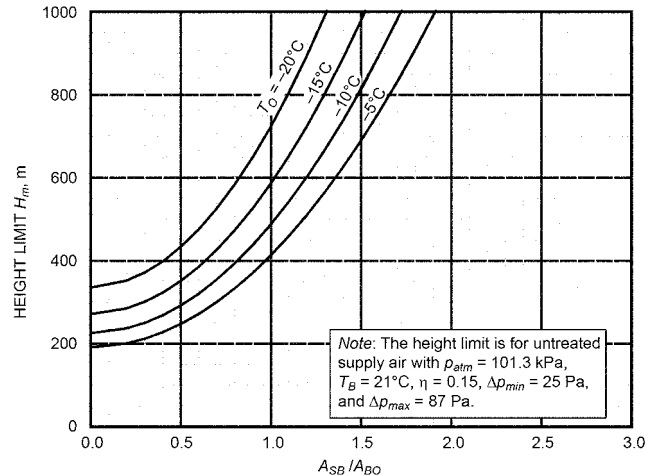

Fig. 14 Height Limit with Untreated Supply Air in Winter

**Height Limit**

For some tall stairwells, acceptable pressurization may not be possible because of indoor-to-outdoor temperature differences. Acceptable pressurization is more likely with systems using untreated supply air than those using treated supply air.

The **height limit** is the height above which acceptable pressurization is not possible for an idealized building. For the height limit to be applicable to a building, all the floors of the building must be the same or relatively similar. When using the height limit, shafts that are not pressurized are neglected. For standard atmospheric pressure at sea level, the height limit is

$$H_m = 2.89 \times 10^{-4} \frac{F_R (\Delta p_{max} - \Delta p_{min})}{\left| \frac{1}{T_O} - \frac{1}{T_S} \right|} \tag{13}$$

where

- $H_m$  = height limit, m
- $F_R$  = flow area factor
- $\Delta p_{max}$  = maximum design pressure difference, Pa
- $\Delta p_{min}$  = minimum design pressure difference, Pa
- $T_O$  = absolute temperature outdoors, K
- $T_S$  = absolute temperature in stairwell, K

The flow area factor is

$$F_R = 1 + \frac{A_{SB}^2 (T_B)}{A_{BO}^2 (T_S)} \tag{14}$$

where

- $A_{SB}$  = flow area between stairwell and building, m<sup>2</sup>
- $T_B$  = absolute temperature in building, K
- $A_{BO}$  = flow area per stairwell between building and outdoors, m<sup>2</sup>
- $T_S$  = absolute temperature in stairwell, K

Figures 13 and 14 show the height limit calculated from Equations (13) and (14) for winter with treated and untreated supply air, respectively. The areas  $A_{SB}$  and  $A_{BO}$  are calculated using effective areas. The effective area of a system of flow areas is the area that results in the same flow as the system when it is subjected to the same pressure difference over the total system of flow paths. The effective area of any number of flow paths in parallel is

$$A_e = \sum_{i=1}^n A_i \tag{15}$$

and the effective area of any number of paths in series is

$$A_e = \left( \sum_{i=1}^n \frac{1}{A_i^2} \right)^{-1/2} \tag{16}$$

where

- $A_e$  = effective area, m<sup>2</sup>
- $A_i$  = flow area of path  $i$ , m<sup>2</sup>

Two examples (Figures 15 and 16) demonstrate evaluation of  $A_{SB}$  and  $A_{BO}$ . The areas on these figures include wall leakage through construction cracks or other paths, including gaps around doors, as appropriate for each section of wall. Figure 15 is a floor plan of a simplified open-plan office building. Because the height limit is based on symmetry, the area  $A_{BO}$  is on a per-stairwell basis. Figure 15 shows the axis of symmetry, and flows and flow paths on one side of this axis are the mirror image of those on the other side. This figure is geometrically symmetric, but the height limit also can be used for buildings where the building is only symmetric with respect to flow. In this figure, the areas between the building and the outdoors are  $A_1, A_2,$  and  $A_3$ . These areas are in parallel, and based on Equation (15),  $A_{BO} = A_1 + A_2 + A_3$ . The areas between the stairwell and the building are  $A_4$  and  $A_5$ , which are also in parallel. Based on Equation (15),  $A_{SB} = A_4 + A_5$ .

The stairwells of Figure 16 have unpressurized vestibules. As with Figure 15,  $A_{BO} = A_1 + A_2 + A_3$ . Calculating  $A_{SB}$  involves flow areas both in parallel and in series. Equation (16) can only be used when no air is supplied to or exhausted from the spaces in the system of series paths. The effective area approach can be used because the only space in this path is an unpressurized vestibule. In Figure 16, the areas  $A_5$  and  $A_6$  are in parallel, so  $A_{56} = A_5 + A_6$ . The path through the vestibule is series, so from Equation (16),  $A_{456} = (1/A_4^2 + 1/A_{56}^2)^{-1/2}$ . The paths  $A_{456}$  and  $A_7$  are in parallel, so  $A_{SB} = A_{456} + A_7$ .

**Example 4.** For the simple building of Figure 17, (1) evaluate wind effect, (2) evaluate stack effect, and (3) determine the design capacity of the supply fans. The height of the building and stairwells is 33.5 m. The minimum and maximum design pressure differences are 25 and 87 Pa.

**Wind Effect.** For this building, wind effect is not considered to be an issue because

- There are no windows or balcony doors that can be opened between the building and the outdoors.
- A centrifugal fan is used to minimize wind effect on the flow rate of pressurization air. (Wind effect can also be minimized by other kinds of fans, although this requires evaluation for the specific case.)

For designs where wind effect is not minimized, CONTAM is recommended for analyzing the stair pressurization system.

**Stack Effect.** Because the example building is only 11 stories tall, stack effect was not an issue. For larger buildings, the impact of stack effect should be analyzed.

The winter outdoor design temperature is  $T_O = -15^\circ\text{C}$ , and the building temperature is  $T_B = 21^\circ\text{C}$ . The atmospheric pressure is 101.3 kPa. Consider a heat transfer factor of  $\eta = 0.15$ . Because the building is simple, height limit can be used to evaluate stack effect. First, evaluate stack effect before stabilization; the first approach for this is to examine the height limit for the stairwell if pressurization air were treated. From Figure 14 with  $T_O = -15^\circ\text{C}$ , the smallest value of height limit is about 45 m when  $A_{SB}/A_{BO}$  is near zero. The stairwell height is 33.5 m, which is less than the height limit. This means that stack effect is not an issue before temperature stabilization; consequently, it cannot be an issue after stabilization.

**Size Supply Fans:** Because this building is simple, the rule of thumb method can be used to size the fans. Generally, rules of thumb for pressurized stairwells are in the range of 0.14 to 0.26  $\text{m}^3/\text{s}$  per floor. The most important factor to consider in choosing a rule of thumb is the stairwell leakage, which primarily consists of the leakage of stairwell walls and stairwell doors.

Construction of the stairwell is believed to be of average leakiness or higher. Table 2 lists supply air of 0.11  $\text{m}^3/\text{s}$  per floor for average leakage, and 0.26  $\text{m}^3/\text{s}$  per floor for high leakage. Because of the cost of replacing an undersized fan, the rule of thumb of 0.21  $\text{m}^3/\text{s}$  per floor is chosen. The stairwell has 11 floors, and fan capacity is  $11(0.21) = 2.31 \text{ m}^3/\text{s}$ . Each stairwell is pressurized by one fan with capacity of 2.31  $\text{m}^3/\text{s}$ .

### Stairwells with Open Doors

When any stair door is opened in a simple stairwell pressurization system, the pressure difference drops significantly. When all doors are closed suddenly in such a simple system, the pressure difference increases significantly. A **compensated stairwell pressurization system** adjusts for changing conditions either by modulating supply airflow or by relieving excess pressure. The intent is to maintain acceptable pressurization when doors are opening and closing.

In the United States, most codes do not require pressurized stairwells to be compensated, and such stairwells are designed to

maintain pressurization only when all the stair doors are closed. Traditionally, some engineers felt that pressurized stairwells needed to be compensated, but research projects by Klote (2004) and Ko and Lougheed (2016) show that noncompensated stairwell pressurization systems can maintain a tenable environment in the stairwell as long as the door on the fire floor remains closed, even if doors on other floors are opened. In computer simulations by Klote and fire experiments by Ko and Lougheed, the small amount of smoke that leaked through the gaps around a closed stair door was diluted by pressurization air and a tenable environment was maintained in the stairwell.

When compensated stairwell pressurization systems are required, the systems described by Klote et al. (2017) can be used: barometric damper (BD), variable-air-volume (VAV), open exterior door (OED), and exterior vent (EV) systems. As with noncompensated stairwell pressurization systems, performance of compensated systems can be negatively affected by wind, and this needs to be taken into account during design. Compensated stairwell pressurization systems have the failure modes discussed in the following paragraphs.

**Barometric Damper (BD) System.** This system has constant-supply airflow, which is designed to maintain acceptable pressurization with the required number of doors open. The supply air rate is not actually constant, but varies to some extent with pressure across the fan. For centrifugal fans, this flow variation is generally small. However, the term *constant supply* is used to differentiate this system from those where the supply air intentionally changes. When a stair door is closed, the excess supply air is relieved to the outdoors through one or more vents with barometric dampers.

Barometric dampers tend to chatter because of the wind. This chatter can be so annoying that building maintenance staff sometimes wire these dampers shut to stop the noise, which can lead to failure because of excessive stair pressurization. Because barometric dampers are usually located on walls, wind can affect system

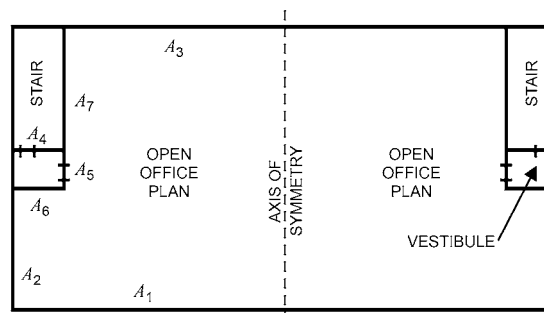

Note: This figure is geometrically symmetric, but height limit can be used for buildings where building is only symmetric with respect to flow.

**Fig. 16 Example for Effective Flow Areas of Building with Pressurized Stairwells and Unpressurized Vestibules**

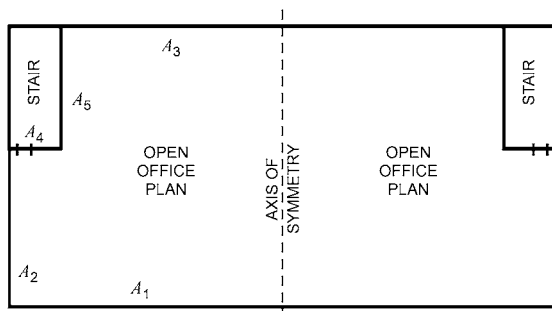

Note: This figure is geometrically symmetric, but height limit can be used for buildings where building is only symmetric with respect to flow.

**Fig. 15 Example for Effective Flow Areas of Building with Pressurized Stairwells**

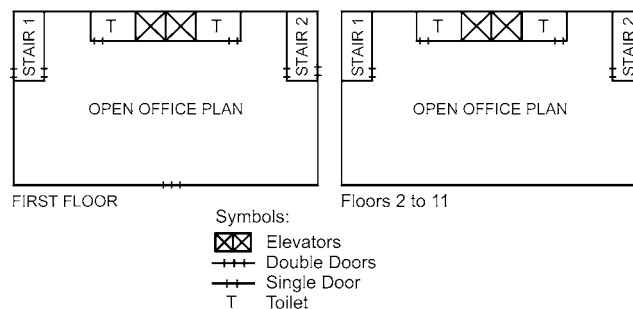

**Fig. 17 Office Building of Stairwell Examples**

performance more than with most other systems. If a BD compensated stairwell pressurization system is to be used, the design needs to mitigate damper chatter and any adverse wind effects.

**Variable-Air-Volume (VAV) System.** In a VAV compensated stairwell system, the flow rate of supply air to the stairwell is adjusted to account for opening and closing of doors. The flow of supply air to the stairwell is controlled by multiple static pressure sensors that sense the pressure difference between the stairwell and the building. When doors are opened, the stairwell pressure drops and the flow rate of supply air is increased to achieve at least the minimum design pressurization. When all the doors are closed, stair pressure increases, and supply air is reduced to prevent excessive pressure differences. When a door is opened in the VAV system, the pressure in the stairwell drops, and it takes about 3 to 7 s for the pressure to recover to the initial value (Tamura 1990).

When the last open door in a VAV system closes, there is a pressure spike that can be on the order of 250 Pa, which is extremely high compared to the usual pressure differences maintained by pressurized stairwells. A person encountering such a peak would probably not be able to open the stair door, but they could open it a minute or so later provided they knew to try. A person encountering such a peak may think the stair door was locked, and might not try to open it again.

Wind can have an unusual and serious impact on VAV systems. During design analysis, engineers have encountered very high pressure differences during some wind conditions. For example, when an exterior door is opened during the design wind speed, there can be so much supply air that the pressure difference across some stair doors can exceed the maximum design value by as much as 100%, making it impossible or extremely difficult for occupants to enter the stairwell.

A VAV compensated stairwell pressurization system design needs to deal with both the pressure spike and the effects of wind on the system. To address these potential failure modes, the design analysis needs to include simulations by network analysis computer program such as CONTAM.

**Open Exterior Door (OED) System.** The open exterior door (OED) system has constant-supply airflow, and an exterior stairwell door that opens automatically on system activation. This system is sometimes called the Canadian system, because it originated in Canada and has been used extensively there. By eliminating opening and closing of the exterior stairwell door during system operation, the OED system eliminates the major source of pressure fluctuations. However, there can be security concerns about exterior doors that open automatically, so OED systems are suggested only for applications where this security issue is not a concern or where the concerns can be resolved with other measures.

**Exterior Vent (EV) System.** The open exterior vent (EV) system is an alternative when security concerns prohibit using the OED system. An EV system has constant-supply airflow and an exterior vent that opens automatically upon system activation. The intent of this vent is to minimize the effect of opening and closing the exterior stair door. To minimize the effect of wind, it is suggested that the vent be near (and facing the same direction as) the exterior door. The size of the vent can be determined by CONTAM simulations.

12. PRESSURIZED ELEVATORS

The elevator pressurization systems discussed in this section are intended to prevent smoke from flowing from the fire floor through an elevator shaft and threatening life on floors away from the fire floor. This section does not address smoke control for elevator evacuation (see Chapter 12 of the *Smoke Control Handbook*). Usually, pressurized elevators are in buildings that have pressurized stairwells, and this section assumes that these pressurization systems operate together. In the rare situation where pressurized elevators

are the only pressurization smoke control system in a building, the information in this section may still be useful. Supply air for pressurized elevators should be free or nearly free of smoke, as discussed in the Smoke Feedback section.

The information discussed in the section on Elevator Piston Effect can be used to evaluate the influence of piston effect on performance of pressurized elevator systems. The piston effect produces a pressure spike when a car passes a particular floor, and this happens for only a few seconds during the run of an elevator. For elevators in multiple-car shafts with car velocities less than 5 m/s, or for those in single-car shafts with car velocities less than 2.5 m/s, piston effect should not adversely affect performance of elevator pressurization.

Design of pressurized elevators is much more complicated than design of pressurized stairwells, because (1) the building envelope often cannot effectively handle the large airflow resulting from both elevator and stairwell pressurization, and (2) open exterior doors on the ground floor can cause high pressure differences across the elevator shaft at the ground floor. Several systems discussed in this section can deal with this complexity, however.

Usually, several exterior doors on the ground floor are open during a building fire: the fire service opens several exterior doors and keeps them open while fighting the fire. Occupants also open exterior doors during evacuation. The shaft pressurization system needs to operate as intended with these exterior doors open.

Generally, a CONTAM analysis is needed to determine whether pressurized elevators and pressurized stairwells in a particular building can be balanced to perform as intended. Though it is theoretically possible to use only a rule of thumb to design these systems, a CONTAM analysis is strongly recommended.

The following discussion is intended to provide an understanding about the elevator pressurization systems, and is based on 36 CONTAM simulations with a 14-story building (Figure 18). For a more detailed discussion of these simulations, see Chapter 11 of the *Smoke Control Handbook*. Elevator pressurization systems discussed here are for use in buildings with pressurized stairwells.

For these simulations, the pressure difference criteria are listed in Table 3. The leakage values and flow coefficients used for these simulations are listed in Tables 4 and 5. For the CONTAM simulations of the example building, supply air was injected only at the top of the elevator shafts, but for stairwells, about half the supply air was injected at the top of the stairs and the rest at the second floor.

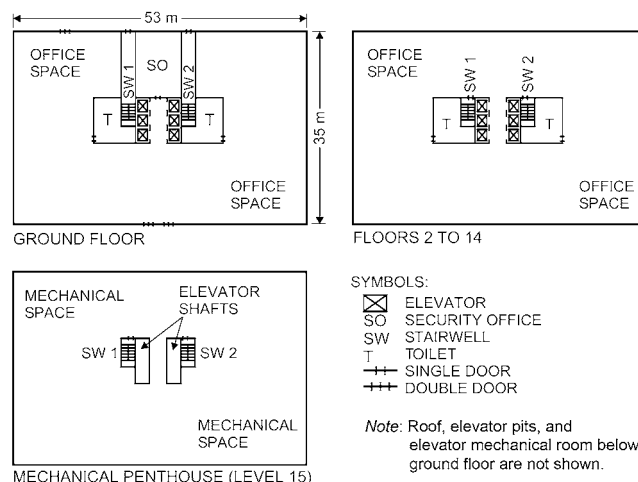

Fig. 18 Floor Plans of Example 14-Story Open Plan Office Building for Elevator Pressurization Study

Licensed for single user. © 2019 ASHRAE, Inc.

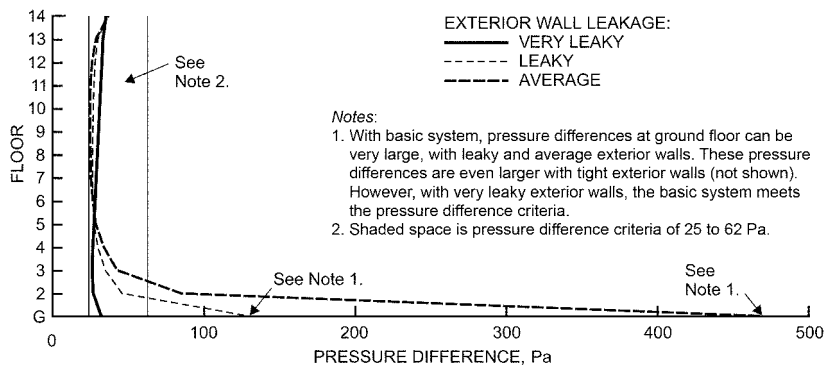

Fig. 19 Elevator Pressure Differences for Basic Elevator Pressurization System

### Basic System

In the basic system, each stairwell and elevator shaft has one or more dedicated fans that supply pressurization air. For reasons mentioned previously, the basic system also includes stairwell pressurization, and the stair subsystems are not compensated. In most buildings, the basic system does not result in successful pressurization, so the systems discussed in this section add extra features to improve performance.

For the example building with very leaky exterior walls, the CONTAM simulations showed that the basic system would perform well, but this was not so for with less leaky exterior walls. In Figure 19, for leaky exterior walls, the pressure difference across the elevator doors on the ground floor is about 130 Pa. For exterior walls of average leakage, the pressure difference across the elevator doors on the second floor is about 87 Pa, and at the ground floor it is about 47 Pa. These values exceed the maximum criterion used for elevator doors, which is 62 Pa (see Table 4). For average and leaky exterior walls, there is insufficient leakage in the building envelope to accommodate the large amount of pressurization air supplied to the shafts.

With very leaky exteriors walls in the example building of Figure 18, Figure 19 shows that the basic system meets the pressure difference criteria (Table 4). Air was supplied to each elevator shaft at 13.1 m<sup>3</sup>/s, and to each stairwell at 3.09 m<sup>3</sup>/s. With very leaky exteriors walls, there is enough wall leakage area to accommodate this large amount of pressurization air. For the few buildings that have very leaky building envelopes, the basic system can be a simple way to pressurize elevators and stairwells. The basic system also might work well for less leaky walls in other buildings. When a CONTAM analysis shows that the basic system does not work for a building, consider the systems discussed in the following sections.

### Exterior Vent (EV) System

This system uses vents in the exterior walls to increase the leakiness of the building envelope such that successful pressurization can be achieved. The vents are usually closed, but they open when the pressurization system is activated. These vents are relatively small and not intended to be a substitute for windows broken open by the fire service. Vents should be located to mitigate the potential for the wind to produce excessive pressures on the fire floor; one way to accomplish this is putting vents on each side of the floor, as shown in Figure 20. These vents may need fire dampers, depending on code requirements.

Figure 20 is a typical floor of the example building with vents in the exterior walls. Vents can be sized to ensure that design criteria are met. In the example building, the vents were sized such that the amount of pressurization used for the basic system produced acceptable pressurization with the EV system in the example building.

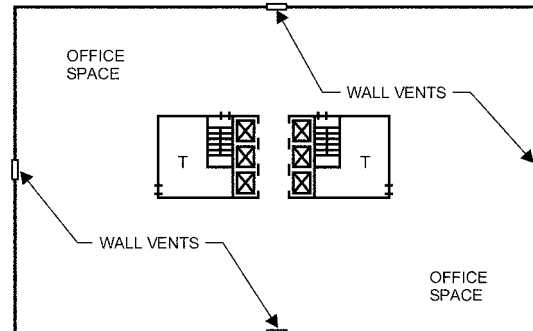

Note: Vents open when elevator and stairwell pressurization is activated.

Fig. 20 Typical Floor Plan of Example Building with Exterior Vent (EV) System

In Figure 20, the vents are in all four exterior walls to minimize any adverse effects of wind. The vent area should be proportional to the area of the exterior walls. If fewer vents are used, wind effects should be incorporated in the CONTAM analysis.

With open exterior doors, it is not necessary to have exterior vents on the ground floor. Because the EV system may not be able to achieve acceptable pressurization with some or all the exterior doors closed, it may be necessary to have some of the exterior doors open automatically on system activation. The number of exterior doors that need to open automatically can be evaluated by CONTAM analysis.

The example building has an open office plan, but the EV system can be adapted to other buildings. Ducted flow paths can be installed from the vicinity of the unenclosed elevator lobbies to the outdoors. Such ducted paths can overcome the flow resistance of interior walls. The ducts can be located above suspended ceilings. Duct penetrations of a fire-rated wall may have fire resistance requirements, depending on code specifications.

### Floor Exhaust (FE) System

The FE system is a kind of zoned smoke control that reduces the amount of supply air used. In the FE system, a relatively small amount of air is supplied to the elevator shafts and the stairwells, and the fire floor is exhausted such that acceptable pressurization is maintained on that floor where it is needed. It is common to also exhaust one or two floors above and below the fire floor.

As discussed in the section on Zoned Smoke Control, exhausting air from the fire floor and some floors above and below the fire floor benefits shaft pressurization. Often, this system can achieve successful pressurization in tall and very complicated buildings.

**Table 3 Pressure Difference Criteria for Elevator Pressurization Simulations, Pa**

System	Minimum	Maximum
Pressurized elevators	25	62
Pressurized stairwells	25	87

Note: Criteria are for elevator simulations discussed in this chapter, but some projects may have different criteria, depending on code requirements and requirements of specific applications.

**Table 4 Flow Areas and Flow Coefficients of Doors Used for Elevator Pressurization Simulations**

Flow Path	Flow Coefficient	Flow Area, m <sup>2</sup>
Single door, closed	0.65	0.023
	0.35	2.0
Double door, closed	0.65	0.045
	0.35	3.9
Elevator door, closed	0.65	0.06
	0.65	0.56

Note: Values were chosen for elevator simulations discussed in this chapter; flow areas and coefficients appropriate for design analysis of a specific building may be different.

**Table 5 Flow Areas and Flow Coefficients of Leakages Used for Elevator Pressurization Simulations**

Flow Path	Leakage Classification	Flow Coefficient	Flow Area, m <sup>2</sup> per m <sup>2</sup> of wall
Exterior walls	Tight	0.65	$0.50 \times 10^{-4}$
	Average		$0.17 \times 10^{-3}$
	Loose		$0.35 \times 10^{-3}$
	Very loose		$0.12 \times 10^{-2}$
Interior walls	Loose	0.65	$0.35 \times 10^{-3}$
Floor or roof	Tight	0.65	$0.66 \times 10^{-5}$
	Average		$0.52 \times 10^{-4}$
	Loose		$0.17 \times 10^{-3}$
<b>m<sup>2</sup> per m of wall</b>			
Curtain wall gap	Tight	0.65	0.00061
	Loose		0.0061

Note: Values were chosen for elevator simulations discussed in this chapter; flow areas and coefficients appropriate for design analysis of a specific building may be different.

Typically, exhaust is through a shaft with a fan located in a mechanical floor or on the roof, and dampers between the shaft and the floors are closed on all floors when the system is not operating. On system activation, the dampers open on the floors to be exhausted. Where the code requires zoned smoke control, it may be necessary to pressurize one or two floors above and below the fire floor. The exhaust rates should be balanced so that the pressure differences from the elevator shaft to the building and from the stairwell to the building are acceptable. This acceptable pressurization meets the intent of the code. At floors not exhausted, pressure differences would be below the minimum design pressure difference. Because the FE system only maintains acceptable pressure differences at the fire floor (and other floors that may be exhausted), use of a FE system needs to be approved by the local code authority.

As with the EV system, some of the exterior doors on the ground floor may need to open automatically upon system activation, and the number of such doors can be evaluated by the CONTAM analysis.

For the example building, an FE system is shown in Figure 21. Simulations showed that each elevator shaft needed 7.14 m<sup>3</sup>/s, and each stairwell needed 1.79 m<sup>3</sup>/s. The floor exhaust needed from the floors ranged from 2.28 to 2.55 m<sup>3</sup>/s.

As with the EV system, the FE system can be adapted to other buildings. This can be done by having the exhaust draw from a space onto which the elevators and stairwells open.

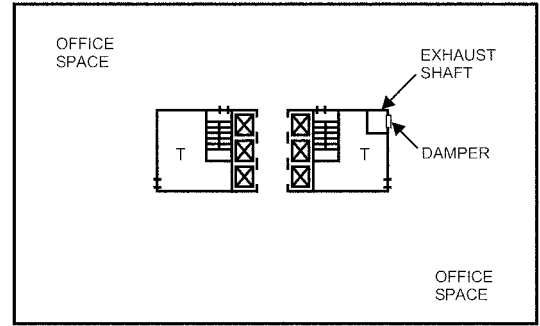

Note: Exhaust shaft has fan (not shown) located in mechanical penthouse, and dampers are closed on all floors when system is not operating. On system activation, dampers open on floors to be exhausted, and fan is activated.

**Fig. 21 Typical Floor Plan of Example Building with Floor Exhaust (FE) System**

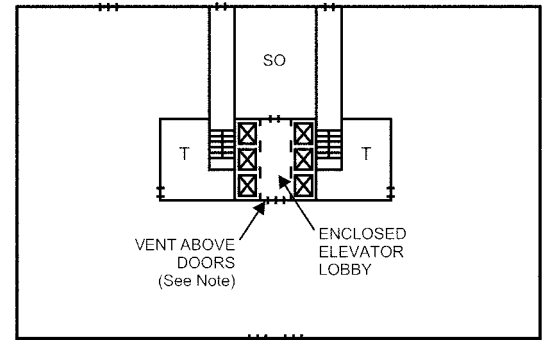

Note: This vent needs fire damper and adjustable damper for balancing.

**Fig. 22 Ground Floor of Building with Ground-Floor Lobby (GFL) System**

**Ground-Floor Lobby (GFL) System**

This system has an enclosed elevator lobby on the ground floor to reduce the tendency of open exterior doors to cause high pressure differences across the elevator shaft at the ground floor. The GFL system often has a vent between the enclosed lobby and the building to prevent excessive pressure differences across the lobby doors (i.e., the doors between the enclosed lobby and the building).

The pressure difference across the lobby door and the elevator door depends on the area of the vent. There is no established criterion for the maximum pressure difference across the lobby doors, but the pressure should not be high enough to prevent the doors from remaining closed. This value depends on the specific doors and hardware. This discussion uses a maximum pressure difference for the lobby doors of 87 Pa, but this value can be much different for specific applications. The vent should have a fire damper and a control damper in series. The control damper can be used to adjust the flow area of the vent so it can be balanced during commissioning. Figure 22 shows the ground floor of the example building with a GFL system.

The intent of the elevator pressurization systems discussed in this chapter is to prevent smoke from flowing from the fire floor through an elevator shaft and threatening life on other floors. In the GFL system, the enclosed lobby on the ground floor protects the elevator from smoke from a fire on the ground floor. Thus, the minimum elevator pressure difference criterion of Table 3 does not apply to the ground floor for a GFL system. Table 6 lists the criteria used for the GFL system simulations. Successful pressurization consists of meeting these criteria.

**Table 6 Pressure Difference Criteria for GFL Elevator Pressurization Simulations, Pa**

Location	Minimum	Maximum
Pressurized elevators on ground floor	N/A	62
on other floors	25	62
Pressurized stairwells on all floors	25	87
Ground-floor elevator lobby door	N/A	87

Note: These pressure differences are with doors to stairwell, elevator, and ground-floor lobby closed. Criteria are for GFL simulations discussed in this chapter; some projects may have different criteria depending on code requirements and requirements of specific applications.

For fires in high-rise buildings, the fire service frequently uses the elevators for rescue and for mobilization of firefighting equipment. When ground-floor lobby doors are opened, the pressure difference may exceed the maximum pressure difference. If this can happen for a particular design, the fire service should be contacted to determine whether this is acceptable to them.

Floor-to-floor leakage can significantly affect a GFL system's performance. This leakage consists of the leakage of the floor and that of the curtain wall gap (Table 6).

### 13. ZONED SMOKE CONTROL

The traditional approach for HVAC systems is to shut them down during building fires, but HVAC systems can be operated in smoke control mode during building fires. Zoned smoke control consists of exhausting the zone of the fire and possibly pressurizing the surrounding zones. In addition to using the HVAC system, dedicated equipment can be used for zoned smoke control. Supply air for zoned smoke control systems should be free or nearly free of smoke, as discussed in the Smoke Feedback section.

In zoned smoke control, a building is divided into several zones, each separated from the others by barriers. In the event of a fire, the zone with the fire is called the **smoke zone**, and the others are called the **nonsmoke zones**. Zones bordering on the smoke zone are called the **surrounding zones**. Either passive or pressurization smoke protection is used to limit smoke spread beyond the smoke zone. Smoke control cannot make conditions tenable in the smoke zone, and occupants should evacuate the smoke zone as soon as possible.

Some arrangements of smoke control zones are shown in Figure 23. In this figure, the smoke zone is indicated by a minus sign, and the surrounding zones are indicated by a plus sign. The smoke zone is often one floor of the building, but it can be the fire floor plus the floors directly above and below the fire floor. In a relatively low, sprawling building with several wings, the smoke zone can be part of a floor.

When separate HVAC systems serve each zone, systems distant from the smoke zone and surrounding zones should only remain operating if the building pressurization produced by these systems does not adversely impact zoned smoke control system performance. Otherwise, they should be shut down.

The traditional approach to zoned smoke control is to exhaust the smoke zone and to pressurize the surrounding zones, but other approaches have been used. Although fan-powered smoke exhaust is the most common method of treating the smoke zone, passive smoke control using smoke barriers may be satisfactory when fan-powered exhaust is not practical. Using exterior wall vents or smoke shafts to treat the smoke zone is not common, but these methods are discussed in Chapter 13 of the *Smoke Control Handbook*.

Fan-powered pressurization or passive smoke control using smoke barriers can be used for the zones surrounding the smoke zone. Fan-powered pressurization of the surrounding zones has a negative consequence on stairwell pressurization, as discussed in the following sections. In this section, fan-powered pressurization is called pressurization, and fan-powered exhaust is called exhaust.

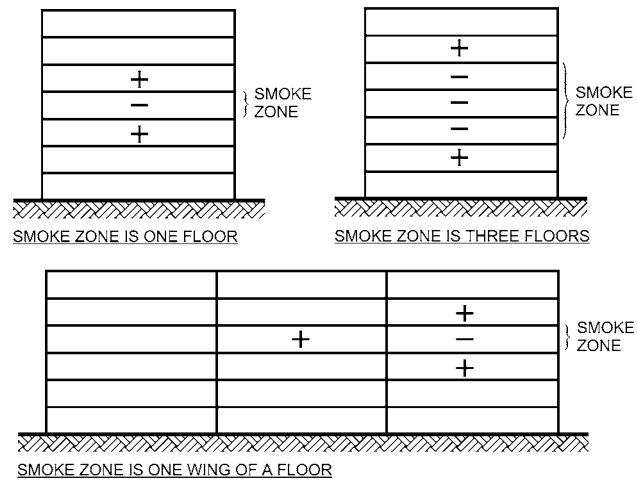

#### Notes:

1. In these figures, smoke zone is indicated by minus sign (-), and surrounding zones are indicated by plus sign (+).
2. Smoke zone can be treated by fan-powered exhaust or passive smoke control using smoke barriers.
3. Surrounding zones can be treated by fan-powered pressurization or passive smoke control using smoke barriers.

**Fig. 23 Some Arrangements of Smoke Control Zones**

When the floors or wings of a building are divided into many rooms with normally closed doors, these floors do not lend themselves to the traditional concept of zoned smoke control. For such applications, a form of zoned smoke control can be used that relies on a combination of corridor exhaust and passive smoke control using smoke barriers. The passive protection tends to minimize smoke flow through the ceiling floor assembly during building fires. Some applications suitable for such an approach are hotel guest floors, apartment buildings, and some office buildings.

### Interaction with Pressurized Stairs

The interaction of zoned smoke control with pressurized stairwells can have a significant effect on pressure differences across the stairwell doors. The following discussion is about smoke zones that are one floor and surrounding zones consisting of one floor above and one floor below. However, the same kind of interactions can happen with smoke zones and surrounding zones that are more than one floor.

The interaction between zoned smoke control and pressurized stairwells is shown in Figure 24. For zoned smoke control using both exhaust and pressurization, pressurization of the surrounding zones decreases the pressure difference  $\Delta p_{SB}$  across pressurized stairwell doors on these floors. This decreased pressure difference can result in failure of pressurized stairwells on the floors being pressurized. However, this failure mode is eliminated by using zoned smoke control that uses exhaust only.

Ideally, exhaust and pressurization zoned smoke control should prevent smoke from reaching the floor above the smoke zone, and negative stairwell pressurization should not compromise tenability of the stairwell. The effectiveness of this depends on proper identification of the fire floor. Properly maintained fire alarm systems are very good at identifying the location of a fire, but no system is perfect. In some fires, the first smoke detector to activate was a floor or so above the fire floor. This can be attributed to any of the following: (1) smoke flowing through a complex route to a floor above the fire, (2) smoke detectors not working properly on the fire floor, and (3) signals from smoke detectors being misidentified.

Regardless of the reason, when a fire floor is incorrectly identified, the smoke zone is incorrectly chosen. In this situation, the failure mode is that inadvertent pressurization of the fire floor can



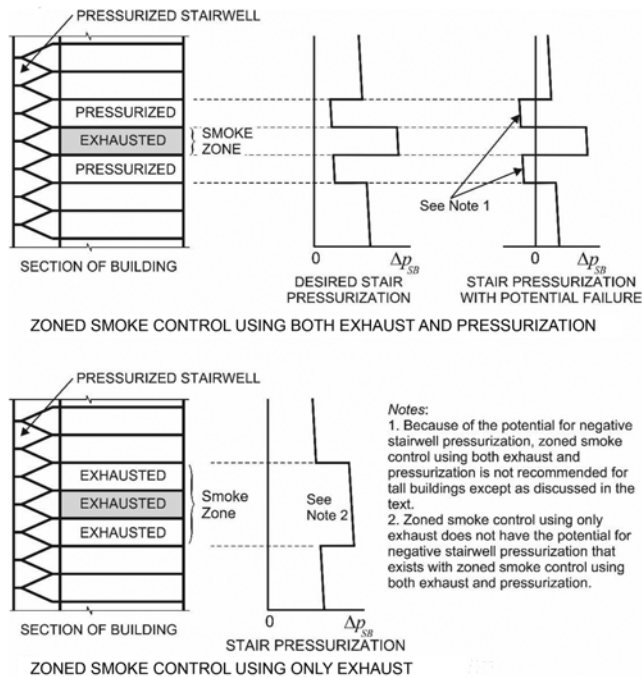

**Fig. 24 Interaction Between Zoned Smoke Control and Pressurized Stairwells**

push smoke into the stairwells (probably into all stairwells serving the fire floor). This failure mode is more of a concern for tall buildings, which are more difficult to pressurize acceptably, and for buildings with 10 or more stories, for which stairwell smoke protection is more critical. Occupant density is another factor affecting the importance of stairwell smoke protection. Because of this failure mode, it is recommended that zoned smoke control using systems using both exhaust and pressurization not be used for tall buildings where protection of the stairwells is especially important. Alternatively, analyze this failure mode, including factors such as evacuation time, emergency response time, and probability of using the firefighter's smoke control station (FSCS) for corrective action.

## 14. ATRIUM SMOKE CONTROL

Because of the lack of compartmentation in large-volume spaces, smoke protection for such spaces is important. This chapter considers a large-volume space to be at least two stories high, such as an atrium, exhibition center, enclosed shopping mall, arcade, sports arena, or airplane hangar.

For simplicity, the term **atrium** is used generically here to mean any of these large spaces.

Most atrium smoke control systems are designed to prevent exposure of occupants to smoke during evacuation; this is the approach described in this section. An alternative goal is to maintain tenable conditions even when occupants have some contact with smoke, as discussed in the section on Tenability Systems.

The following approaches can be used to manage smoke in atriums:

- **Smoke filling.** This approach allows smoke to fill the atrium space while occupants evacuate the atrium. It applies only to spaces where the smoke-filling time is sufficient for both decision making and evacuation. For information about people movement and evacuation time, see Chapter 4 of the *Smoke Control Handbook*. The filling time can be estimated either by

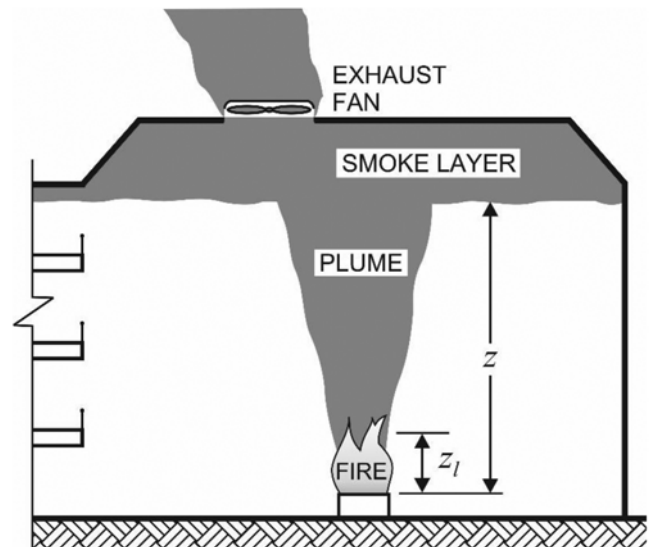

**Fig. 25 Atrium Smoke Exhaust**

zone fire models or by Equations (15.1) and (15.2) in the *Smoke Control Handbook*.

- **Unsteady smoke exhaust.** This approach exhausts smoke from the top of the atrium at a rate such that occupants have sufficient time for decision making and evacuation. It requires analysis of people movement and fire model analysis of smoke filling.
- **Steady smoke exhaust.** This approach exhausts smoke from the top of the atrium to achieve a steady smoke layer height for a steady fire (Figure 25). A calculation method is given in the section on Equations for Steady Smoke Exhaust.

## Design Fires

Analysis of the design fire is extremely important for atrium smoke control design, and an understanding of fire development is needed for such analysis. The intent of this section is to provide preliminary information of these topics. For more complete information, see Chapter 5 of the *Smoke Control Handbook*. By nature, fire is an unsteady process, but many design fires are steady fires. One of the most important aspects of a design fire is the **heat release rate (HRR)**. Other fuel properties (e.g., heat of combustion, soot yield) are not discussed here, because they are not used in the calculations in the Equation Method for Steady Smoke Exhaust section. However, such fuel properties are needed for CFD simulations that include tenability analysis.

When steady design fires are based on test data, it is accepted that the HRR of the steady fire is taken as the maximum HRR of the test data. For example, the HRR of upholstered furniture from test data is shown in Figure 26. For a sofa, the HRR grows to a maximum of about 3200 kW, then decreases as the fuel burns out. A sofa design fire could be unsteady based on the fire test data, or it could be a steady 3200 kW.

A design scenario is an outline of events and conditions that are critical to determining the outcome of alternative situations or designs. In addition to the fire location and HRR, it may include many other conditions such as materials being burned, outdoor temperature, wind, status of the HVAC system, and doors that are opened and closed.

A design analysis should include several design scenarios to ensure that the smoke control system will operate as intended. It is possible for an atrium project to have only one scenario, but most projects have two or three, and some complex projects require five or more.

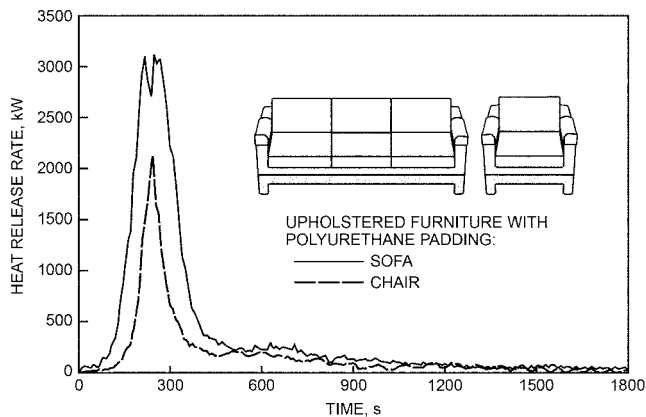

Fig. 26 HRR of Upholstered Sofa and Chair

### Fire Development

The stages of fire development are useful when discussing fires. These stages are (1) growth, (2) flashover, (3) fully developed fire, and (4) decay. Not all fires go through all the stages, primarily because of fire suppression or a lack of fuel. The growth stage follows ignition, and the early part of the growth stage is characterized by an abundance of air for the fire. During the growth stage, the fire often spreads from one object to another. The growth stage of a sofa fire is from ignition to the peak HRR of about 3200 kW. The growth stage is often characterized by the following equation:

$$q = 1000 \left( \frac{t}{t_g} \right)^2 \quad (17)$$

where

- $q$  = heat release rate, kW
- $t$  = time, s
- $t_g$  = growth time, s

Such a growth stage is called a ***t*-squared fire**, and typical growth times are listed in Table 7.

Development of a room fire in the growth stage may seem gradual. Smoke rises above the fire to form a smoke layer under the ceiling. Typically, the fire spreads from object to object, while the temperature of the smoke layer increases.

**Flashover** is a rapid change from a growth-stage fire to a fully developed fire, and primarily occurs by thermal radiation. This radiation is from the flames, the smoke plume, and the hot smoke layer below the ceiling. Thin, easy-to-ignite materials (newspapers, draperies, etc.) near the fire are the first to burst into flame, and this is followed by ignition of the rest of the flammable materials in the room.

In a room with a fully developed fire, everything that can burn is burning. A fully developed fire also is called a **ventilation-controlled fire**, because the HRR depends on the amount of air that reaches the fire. During a fully developed fire, flames generally extend from the doorways or open windows of the fire room. A fully developed fire is characterized by inefficient combustion resulting in high carbon monoxide production. For a fully developed fire in room with one opening, the HRR within the fire room can be expressed as

$$q = 1260A_w H_w^{1/2} \quad (18)$$

where

- $q$  = heat release rate of fully developed fire, kW
- $A_w$  = area of ventilation opening, m<sup>2</sup>
- $H_w$  = height of ventilation opening, m

Table 7 Typical Fire Growth Times

<i>t</i> -Squared Fire	Growth Time $t_g$ , s
Slow	600
Medium	300
Fast	150
Ultrafast	75

Note: Growth times from NFPA Standards 92 and 204.

For example, a fully developed fire in a room with a single door 1.07 by 2.13 m has an HRR of 4190 kW. The decay stage is a decrease in the HRR, which results from either fuel consumption or fire suppression. As the fuel is consumed, the fire may change from ventilation controlled to fuel controlled.

### Sprinklers

Sprinklers are used extensively because they effectively suppress fires. The possible responses to sprinkler spray include (1) HRR decay, (2) constant HRR, or (3) an increase in HRR. The first two responses might be considered successful suppression, but in the third case, the sprinkler spray is overpowered by the fire.

Sprinkler actuation depends on the temperature and velocity of the gases flowing by the sprinkler and on the responsiveness of the sprinkler. The responsiveness of a sprinkler is characterized by the **response time index (RTI)**. In a fire, a ceiling jet of hot gases flows in a radial direction from where the smoke plume contacts the ceiling. The RTI of standard-response sprinklers is greater than or equal to 80 m<sup>1/2</sup>·s<sup>1/2</sup>; fast-response sprinklers' RTIs are equal to or less than 50 m<sup>1/2</sup>·s<sup>1/2</sup>. Computer programs can use the RTI and correlations for the ceiling jet to predict sprinkler actuation time, and some zone fire models (including CFAST, discussed in the section on Zone Fire Modeling) have this ability.

In spaces with high ceilings (greater than about 8 or 11 m), the temperature of the smoke plume can drop so much that sprinklers may not activate, or activation may be so delayed that the spray can evaporate before it reaches the fire. Sprinklers in an atrium could have some beneficial effect, but for design purposes they are considered not effective in an atrium. However, they are usually considered effective for fires in communicating spaces (i.e., a space with an open pathway to an atrium, such that smoke from a fire in either the atrium or the communicating space can move from one to the other without restriction). Fires in communicating spaces are often included in design scenarios.

### Shielded Fires

A fire can be shielded from the sprinkler spray if an obstruction is between the sprinkler and the fire. Not only does the obstruction shield the fire from the water spray, but it also prevents the usual formation of a smoke plume. Because the smoke plume of a shielded fire can be very different from that of an unshielded fire, the sprinkler actuation time of shielded fires must not be calculated by the computer methods mentioned previously.

Two models have been developed for the HRR of shielded fires, based on test data. At NIST, fire tests were based on a few field observations of fuel loadings in office buildings (Madrzykowski and Vettori 1992), with a peak HRR of shielded fires of 500 kW. At the National Research Council of Canada (NRCC), fire tests were based on extensive field observations of fuel loadings in many buildings (Lougheed 1997), with a peak HRR of shielded fires of 1000 kW.

A peak HRR of 1000 kW is suggested for most shielded fires, and an HRR of 500 kW for locations where fuel is limited, such as in a showplace office of the president of a large corporation.

## Transient Fuels

Transient fuels are materials that are in a space temporarily. Examples include seasonal decorations, paint and solvents in stairwells during redecorating, unpacked foam cups in cardboard boxes after delivery, cut-up cardboard boxes awaiting removal, upholstered furniture after delivery, stacked folding chairs, and materials from special events such as parties or dinners. Sometimes, transient fuels remain in place for long periods: for instance, polyurethane-filled mattresses delivered to a dormitory and waiting for distribution in the next school year, automobiles on display in a shopping mall, boats and campers on display in an arena, and a two-story wood frame house built for display inside a shopping mall.

Transient fuel is likely to accumulate at most locations in a building, except where it would block the usual paths of heavy traffic. It is unlikely that a commonly used building entrance or corridor would be blocked by transient fuel, but there could be accumulations next to a wall near the entrance or in the corridor.

Location can play a key role in transient fuels. Consider a sofa with polyurethane foam padding that is delivered for the office of the corporate president. Because the sofa is new and clean, it is decided to temporarily leave it in the nearby atrium until it can be moved to the president's office. In a corridor of an office building, the fuel could be trash consisting of any number of things such as an old upholstered chair or cardboard boxes with packing materials.

## Suggested Fire Sizes

In many atriums, fuel loading is severely restricted with the intent of restricting fire size. Such atriums are characterized by interior finishes of metal, brick, stone, or gypsum board and furnished with objects made of similar materials, plus plants. In this chapter, a heat release rate per floor area of 225 kW/m<sup>2</sup> is used for a fuel-restricted atrium, and 500 kW/m<sup>2</sup> is used for atriums containing furniture, wood, or other combustible materials. These heat release rates per unit floor area are from Morgan (1979) and Morgan and Hansell (1987). In a fuel-restricted atrium, transient fuels must not be overlooked when selecting a design fire. The minimum fire is often considered as occupying 9.29 m<sup>2</sup> of floor area. The HRR of the minimum transient fire is (225 kW/m<sup>2</sup>)(9.29 m<sup>2</sup>) = 2100 kW. The HRR of the minimum fire with combustibles is (500 kW/m<sup>2</sup>)(9.29 m<sup>2</sup>) = 4600 kW. However, the area involved in fire can be much greater, and large fires can easily occupy 22 to 52 m<sup>2</sup> of floor area. This translates to large fires ranging from 11 000 to 26 000 kW. Table 8 lists some steady design fires, but an engineering analysis as discussed in Chapter 5 of the *Smoke Control Handbook* can result in different fire sizes. The large fires in Table 8 are not often used for design, but they represent an atrium with a large amount of fuel such as many upholstered sofas and chairs.

## Atrium Smoke Filling

Atrium smoke filling is only applicable to very large atriums. Atrium smoke filling time can be calculated by empirical equations for steady fires and for *t*-squared fires in NFPA *Standard* 92 and Chapter 15 of the *Smoke Control Handbook*. These equations are based on the conventional approach of keeping smoke from coming into contact with occupants during evacuation. In very large atriums, smoke can often be diluted to the extent that a tenable environment is maintained for some time in the smoke layer at the top of the atrium. Design analysis of atrium filling is usually done with CFD modeling and tenability analysis (see the section on Tenability Systems).

## Loss of Buoyancy in Atriums

For some applications, loss of buoyancy can cause the smoke layer to descend and threaten occupants. There is little research on this event, but the geometry of the large-volume space and the fire's

**Table 8 Steady Design Fire Sizes for Atriums**

	kW
Minimum fire for fuel-restricted atrium	2100
Minimum fire for atrium with combustibles	4600
Large fires	11 000 to 26 000

*Note:* These fire sizes apply to fire in the atrium space, but not to fires in communicating spaces in fully sprinklered buildings.

heat release rate are major factors. Spaces that are unusually large or unusually long are of particular concern; for these cases, draft curtains can divide up the atrium into several smaller spaces. Theoretically, CFD modeling can predict loss of buoyancy in a large-volume space, but this has not been experimentally verified.

## Minimum Smoke Layer Depth

The ceiling jet and smoke flow under the jet each have a depth of about 10% of the floor-to-ceiling height. Thus, the minimum smoke layer depth should be 20% of the floor-to-ceiling height, except when an engineering analysis using full-scale data, scale modeling, or computational fluid dynamic (CFD) modeling indicates otherwise (see the section on CFD Modeling). For information about scale modeling and full-scale fire testing, see Chapters 21 and 22 of the *Smoke Control Handbook*.

## Makeup Air

Makeup air needs to be provided to ensure that exhaust fans can move the design air quantities and to ensure that door-opening force requirements are not exceeded. Makeup air can be provided using fans, openings to the outdoors, or both. Supply points for makeup air need to be below the smoke layer. Makeup air should be free or nearly free of smoke, as discussed in the section on Smoke Feedback.

Makeup air can be provided by mechanical fans or openings to the outdoors (e.g., opened doors or windows). When makeup air is supplied by fans, the makeup air system should be designed to provide 85 to 95% of the exhaust mass flow rate (not volumetric flow rate). The remaining 5 to 15% of makeup air enters as leakage through cracks in the construction, including gaps around closed doors and windows. Evaluation of this leakage needs to take energy standards into account. Makeup air fans can be activated concurrent with smoke exhaust fans, but the flow rate of makeup air fans should always be less than that of the smoke exhaust fans.

When makeup air enters through openings to the outdoors, (1) the mass airflow through these openings should be considered the same as that of the smoke exhaust, and (2) the openings need to be opened automatically before the smoke exhaust fans are activated.

Hadjisophocleous and Zhou (2008) and Zhou and Hadjisophocleous (2008) show that, for makeup air velocities exceeding 1.02 m/s, the plume can be deflected, resulting in an increase in smoke production. For even higher velocities, the plume and smoke layer can be disrupted. The maximum air velocity must not exceed 1.02 m/s if the makeup air could come into contact with the smoke plume, unless a higher velocity is supported by engineering analysis. A secondary reason for the 1.02 m/s restriction is that it reduces the potential for fire growth and spread caused by airflow. For systems using fans, the exhaust fans should operate before the makeup air system does.

A CFD study of makeup air velocity conducted at the University of Maryland supports higher makeup air velocities higher than 1.02 m/s, provided that there is an appropriate increase in smoke exhaust flow rate and that the higher velocity does not increase fire spread or growth (ASHRAE research project RP-1600; Pongratz et al. 2016). The study examined 1, 2.5, and 5 MW fires. A method of determining the increase in smoke exhaust was developed, and one

of the factors is the height of the makeup air supplied relative to the flame height.

When makeup air is supplied through openings, the wind can affect makeup air velocity. When makeup air openings are on walls facing different directions, wind can increase the makeup air velocity. A simple approach is to have all makeup air openings on walls facing the same direction. Although many code authorities do not require it, a wind analysis is suggested to mitigate the possibility of excessive makeup air velocity when makeup air openings are on walls facing different directions.

### Stratification and Detection

A layer of hot air often forms under the ceiling of an atrium because of solar radiation on the atrium roof. Although no studies have been made of this stratification layer, building designers indicate that its temperature can exceed 50°C. Temperatures below this layer are controlled by the building's heating and cooling system.

When the average temperature of the plume is lower than that of the hot-air layer, a stratified smoke layer will form beneath the hot-air layer. In this situation, smoke cannot be expected to reach the atrium ceiling, and smoke detectors mounted on that ceiling cannot be expected to go into alarm.

**Beam smoke detectors** can overcome this detection difficulty. The following approaches can provide prompt detection regardless of air temperature under the ceiling when a fire begins:

- **Upward-Angled Beam to Detect Smoke Layer.** One or more beams are aimed upward to intersect the smoke layer regardless of the level of smoke stratification. For redundancy, more than one beam smoke detector is recommended. Advantages include not needing to locate several horizontal beams, and minimized risk of false activation by sunlight (a risk with some beam smoke detectors), because the receivers are angled downward. Review the manufacturer's recommendation when using beam smoke detectors for this application, because some beam detectors are not recommended for upward-angled installation.
- **Horizontal Beams at Various Levels to Detect Smoke Layer.** One or more beam detectors are located at roof level, with additional detectors at lower levels. Exact beam positioning depends on the specific design, but should include beams at the bottom of identified unconditioned spaces and at or near the design smoke level, with several beams at intermediate positions.
- **Horizontal Beams to Detect Smoke Plume.** Beams are arranged below the lowest expected stratification level. These beams must be close enough to each other to ensure intersection of the plume; spacing should be based on the width of the plume at the least elevation above a point of fire potential.

All components of a beam smoke detector must be accessible for maintenance, which may require maintenance openings in walls or the roof depending on the application.

### Equation Method for Steady Smoke Exhaust

This section describes the algebraic equation method for analysis of atrium smoke control systems with a steady fire. A steady atrium smoke exhaust system has a steady smoke layer interface and a fire with a constant HRR. The smoke layer interface is an idealized concept described in the section on Zone Fire Modeling, and the equations used here are used in some zone fire models. There is some diluted smoke below the smoke layer interface, but this diluted smoke is considered insignificant. CFD modeling can calculate tenability of this diluted smoke.

For a case study of an engineering analysis for a three-story atrium that uses the algebraic equations of this section, see Chapter 16 of the *Smoke Control Handbook*. This case study addresses (1) the impact of wind, (2) determination of the minimum smoke layer depth, (3) system activation with a stratified hot-air layer, (4)

analysis of design scenarios, (5) calculation of smoke exhaust for a fire in the atrium, (5) calculation of smoke exhaust for a fire with a balcony spill plume, (6) determination of makeup air, and (7) evaluation of the number of exhaust inlets and separation between them to prevent plugholing.

Readers who need to analyze atriums by the equation method may want to use AtriumCalc (Klote 2014), which uses common routines for designing atrium smoke control systems. For example, one routine calculates the smoke exhaust needed to maintain a steady smoke layer height when there is a steady design fire in the atrium with an axisymmetric plume. Each routine can be printed on a page suitable to be inserted in an engineering report. The page consists of a relevant figure, the equations used for calculation, input, and output. Other routines address balcony spill plumes, window plumes, preventing plugholing, and opposed airflow.

For an atrium fire, most of the heat flows upward in the smoke plume, and practically the rest of the heat leaves the fire by radiation. Heat transfer from fires by conduction is negligible. The convective heat release rate is expressed as

$$q_c = \chi_c q \quad (19)$$

where

$\chi_c$  = convective fraction

$q_c$  = convective heat release rate, kW

$q$  = heat release rate, kW

The convective fraction depends on the material being burned, heat conduction through the fuel, and the radiative heat transfer of the flames, but a value of 0.7 is usually used. For fire reconstruction, the specific value of the fuel being burned must be used.

### Fire in Atrium

For a fire in an atrium, the mass flow rate of the plume is usually calculated by the empirical plume equations for axisymmetric plumes. Theoretically, an axisymmetric plume has a round cross section, but the plumes of many burning objects behave like an axisymmetric plume at some distance above the fire.

For a distance above the base of fire  $z$  equal to or greater than the **limiting elevation**  $z_l$ , the mass flow of the plume is

$$m = 0.071q_c^{1/3}z^{5/3} + 0.0018q_c \quad (20)$$

For  $z < z_l$ , the mass flow of the plume is

$$m = 0.032q_c^{3/5}z \quad (21)$$

where

$m$  = mass flow in axisymmetric plume at height  $z$ , kg/s

$q_c$  = convective heat release rate of fire, kW

$z$  = distance above base of fire to smoke layer interface, m

$z_l$  = limiting elevation, m

The limiting elevation is approximately the average flame height, which is

$$z_l = 0.166q_c^{2/5} \quad (22)$$

For a burning solid (e.g., chair, sofa, desk), the base of the fire is some distance above the floor (see Figure 25). When a flammable liquid has spilled and is burning, the base of the fire is at the floor.

Figures 27 and 28 show the smoke layer temperature and the smoke exhaust rate for fires in an atrium with an axisymmetric plume. The mass flow was calculated from the preceding equations, and the smoke layer temperature and volumetric flow were calculated by equations discussed in the following sections. As  $z$  increases, the smoke layer temperature decreases (Figure 27) as a consequence of air being entrained by the plume as it rises. The

plume mass flow increases with height, and plume temperature decreases with height. Figure 28 shows that as  $z$  increases, the smoke exhaust rate increases.

**Example 5.** For a 2100 kW fire in an atrium with a distance from the base of the fire to the smoke layer interface of 11 m, what is the mass flow of the plume? The parameters are:  $q = 2100$  kW,  $z = 11$  m, and  $\chi_c = 0.7$ .

$$q_c = \chi_c q = 2100(0.7) = 1470 \text{ kW}$$

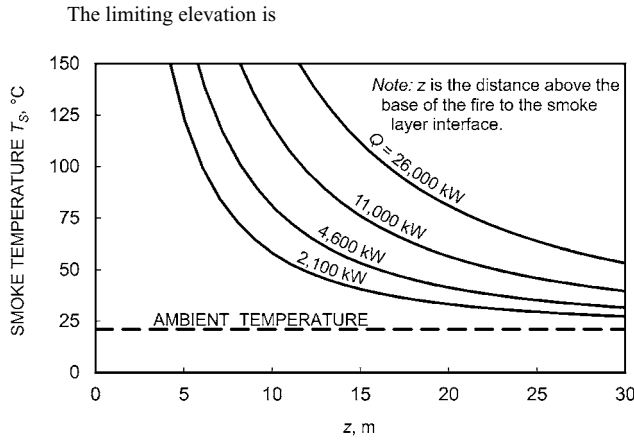

Fig. 27 Smoke Layer Temperature for Steady Smoke Exhaust Systems

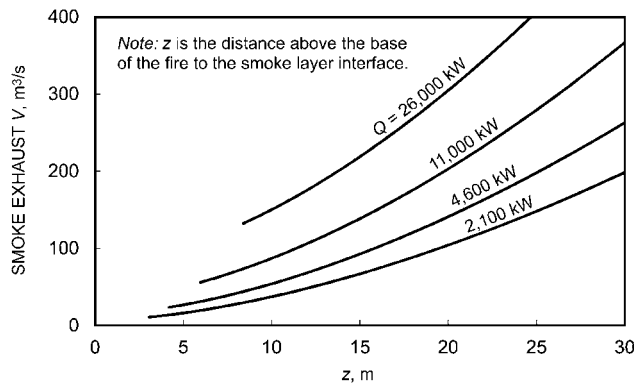

Fig. 28 Smoke Exhaust Rate for Steady Smoke Exhaust Systems

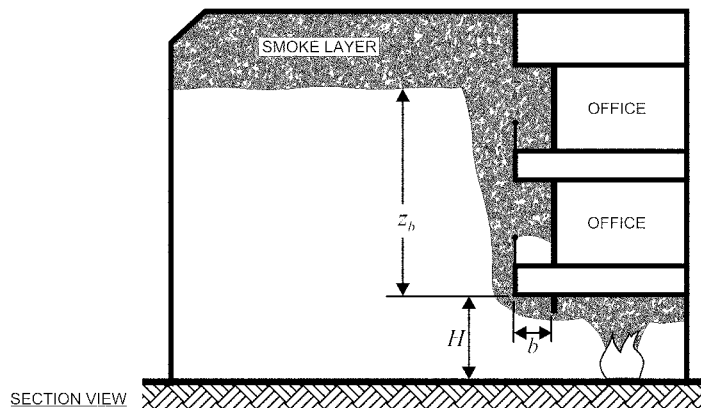

Fig. 29 Balcony Spill Plume

$$z_l = 0.166q_c^{2/5} = 0.166(1470)^{2/5} = 3.1 \text{ m}$$

Because  $z$  is greater than  $z_b$ , the mass flow of the plume is calculated with the following equation:

$$m = 0.071q_c^{1/3}z^{5/3} + 0.0018q_c = 0.071(1470)^{1/3}(11)^{5/3} + 0.0018(1470)$$

$$m = 46.6 \text{ kg/s}$$

### Fire in Communicating Space

For a fire in a communicating space, usually the mass flow rate of the plume is calculated by balcony spill plume equations. The following equations are based on extensive research, including scale model fire experiments, full-scale fire experiments, and analytical studies (Ko et al. 2008; Law 1986; Loughheed and McCartney 2008a, 2008b; Loughheed et al. 2007; McCartney et al. 2008; Morgan and Marshall 1979).

The equations were developed for fire room and balcony geometry similar to that of Figure 29. If the geometry is different, CFD modeling is recommended. For plume height  $z_b$  less than 15 m above the balcony edge, the mass flow of the plume is

$$m = 0.36(qW^2)^{1/3}(z_b + 0.25H) \quad (23)$$

Note: the mass flow equations and regions of applicability for the equations listed here have been corrected. NFPA issued errata correcting balcony spill plume equations in NFPA Standard 92-2012. There is an erratum for the bounds of one of these equations in the *Smoke Control Handbook*.

For  $z_b \geq 15$  m and plume width of less than 10 m, mass flow of the plume is

$$m = 0.59q_c^{1/3}W^{1/5}(z_b + 0.17W^{7/15}H + 10.35W^{7/15} - 15) \quad (24)$$

For  $z_b \geq 15$  m and plume width between 10 and 14 m, the mass flow of the plume is

$$m = 0.2(q_cW^2)^{1/3}(z_b + 0.51H + 15.75) \quad (25)$$

where

- $m$  = mass flow rate in plume, kg/s
- $q$  = heat release rate, kW
- $q_c$  = convective heat release rate of fire, kW
- $W$  = width of the spill, m
- $z_b$  = height of plume above balcony edge, m
- $H$  = height of balcony above fuel, m

Physical barriers can be used to restrict the horizontal spread of smoke under the balcony. Draft curtains used for this application must extend at least 10% of the floor-to-ceiling height below the

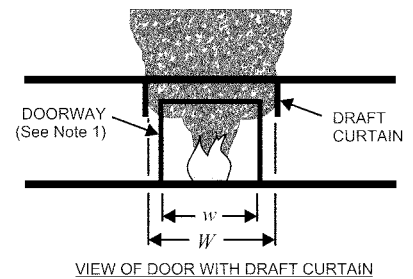

Notes:

1. Doorway height of fire room is not more than 90% of  $H$ .
2. Atrium smoke exhaust is not shown.

balcony. In almost all U.S. and Canadian applications, there are no draft curtains to restrict flow as shown in Figure 29. Without draft curtains, the spill width is estimated as

$$W = w + b \quad (26)$$

where

- $W$  = width of spill, m
- $w$  = width of opening from area of origin, m
- $b$  = distance from opening to balcony edge, m

**Example 6.** For a 1000 kW shielded fire in a communicating space as shown in Figure 29, calculate the mass flow of the balcony spill plume. There are no draft curtains to restrict the smoke flow under the balcony. The parameters are  $q = 1000$  kW,  $z_b = 8$  m,  $H = 3.4$  m,  $b = 1.8$  m, and  $w = 4$  m.

The width of the spill is

$$W = w + b = 5.8 \text{ m}$$

Because  $z_b$  is less than 15 m, Equation (23) is used to calculate the mass flow of the balcony spill plume:

$$m = 0.36(qW^2)^{1/3}(z_b + 0.25H) = 0.36[1000(5.8)^2]^{1/3}[8 + 0.25(3.4)] = 103 \text{ kg/s}$$

### Smoke Layer Temperature

The smoke layer temperature is calculated from

$$T_s = T_o + \frac{Kq_c}{mC_p} \quad (27)$$

where

- $T_s$  = smoke layer temperature, °C
- $T_o$  = ambient temperature, °C
- $K$  = fraction of convective heat release contained in smoke layer
- $q_c$  = convective heat release rate, kW
- $C_p$  = specific heat of plume gases, 1.0 kJ/(kg·K)
- $m$  = mass flow rate of plume where it enters smoke layer, kg/s

Equation (27) applies to both axisymmetric plumes and balcony spill plumes. For atrium smoke control systems, it is believed that  $K$  varies from 0.5 to 1.0. For calculating the volumetric flow rate of smoke exhaust with Equation (23), use  $K = 1.0$  because it results in the highest smoke exhaust, which is conservative. For plugholing calculations (see the following section on Number of Exhaust Inlets), use  $K = 0.5$  because it results in the largest number of exhaust inlets, which is also conservative. Other values of  $K$  may be used for these applications if they are supported by test data or an engineering analysis. The mass flow rate is calculated from Equations (20) or (21).

### Volumetric Flow of Smoke Exhaust

Volumetric flow of smoke exhaust is

$$V = \frac{m}{\rho} \quad (28)$$

where

- $V$  = volumetric flow rate of smoke exhaust, m<sup>3</sup>/s
- $m$  = mass flow rate of smoke exhaust, kg/s
- $\rho$  = density of smoke, kg/m<sup>3</sup>

The density of smoke can be calculated from

$$\rho = \frac{p_{atm}}{RT_s} \quad (29)$$

where

- $\rho$  = density of smoke, kg/m<sup>3</sup>
- $p_{atm}$  = atmospheric pressure, Pa

- $R$  = gas constant, 287 J/(kg·K)
- $T_s$  = absolute temperature of smoke, K

The standard atmospheric pressure  $p_{atm}$  for many locations is provided in Chapter 2 of the *Smoke Control Handbook*.

**Example 7.** What is the volumetric flow rate for the mass flow rate from Example 5? A few minutes after system activation, the air temperature in the atrium is the same as that of the outdoors, and the largest volumetric flow rate happens during summer when it is hot outdoors. The summer outdoor design temperature is 35°C. The parameters are  $T_o = 35^\circ\text{C}$ ,  $m = 46.6$  kg/s,  $q_c = 1470$  kW,  $C_p = 1.0$ ,  $R = 287$  J/(kg·K), and  $p_{atm} = 101.3$  kPa. For calculation of smoke exhaust,  $K = 1$ .

$$T_s = T_o + \frac{Kq_c}{mC_p} = 35 + \frac{1(1470)}{46.6(1)} = 67^\circ\text{C} \quad (340 \text{ K})$$

$$\rho = \frac{p_{atm}}{RT_s} = \frac{101300}{287(340)} = 1.04 \text{ kg/m}^3$$

### Number of Exhaust Inlets

When the flow rate of a smoke exhaust inlet is relatively large, cold air from the lower layer can be pulled through the smoke layer into the smoke exhaust. This phenomenon is called **plugholing**. Multiple exhaust air inlets may be needed to prevent plugholing. The maximum volumetric flow rate that can be exhausted by a single exhaust inlet without plugholing is calculated by

$$V_{max} = 4.16\gamma d^{5/2} \left( \frac{T_s - T_o}{T_o} \right)^{1/2} \quad (30)$$

where

- $V_{max}$  = maximum volumetric flow rate without plugholing at  $T_s$ , m<sup>3</sup>/s
- $T_s$  = absolute temperature of smoke layer, K
- $T_o$  = absolute ambient temperature, K
- $d$  = depth of smoke layer below lowest point of exhaust inlet, m
- $\gamma$  = exhaust location factor

The ratio  $d/D_i$  should be greater than 2 where  $D_i$  is the diameter of the exhaust inlet. For exhaust inlets centered no closer than  $2D_i$  from the nearest wall,  $\gamma = 1$  should be used; for less than  $2D_i$ ,  $\gamma = 0.5$  should be used. For exhaust inlets on a wall, use  $\gamma = 0.5$ . For rectangular exhaust inlets, calculate  $D_i$  as

$$D_i = \frac{2ab}{a+b} \quad (31)$$

where

- $a$  = length of the inlet, m
- $b$  = width of the inlet, m

The variables  $a$  and  $b$  can be in any unit of length provided that they are both in the same units. For square inlets,  $D_i$  equals the side of the square. Where multiple inlets are needed to prevent plugholing, the minimum separation between inlets should be

$$S_{min} = 0.9V_e^{1/2} \quad (32)$$

where

- $S_{min}$  = minimum edge-to-edge separation between inlets, m
- $V_e$  = volumetric flow rate of one exhaust inlet, m<sup>3</sup>/s

**Example 8.** For the fire of Example 7, determine the number of smoke exhaust inlets and the minimum separation between them to prevent plugholing. The smoke layer is 3.2 m deep. Because the inlets in the ceiling are far from walls,  $\gamma = 1$ . Plugholing will be calculated for an ambient temperature of 21°C. The parameters are  $\gamma = 1$ ,  $d = 3.2$  m,  $T_o = 21^\circ\text{C}$  (294 K),  $m = 46.6$  kg/s,  $q_c = 1470$  kW,  $C_p = 1.0$ , and  $V = 44.8$  m<sup>3</sup>/s. For calculating the number of exhaust inlets,  $K = 0.5$ .

$$T_s = T_o + \frac{Kq_c}{mC_p} = 21 + \frac{0.5(1470)}{46.6(1.0)} = 36.8^\circ\text{F} (309.8 \text{ K})$$

$$V_{max} = 4.16\gamma d^{5/2} \left( \frac{T_s - T_o}{T_o} \right)^{1/2}$$

$$= 4.16(1)(3.2)^{5/2} \left( \frac{309.8 - 294}{294} \right)^{1/2} = 17.7 \text{ m}^3/\text{s}$$

$V/V_{max}$  is  $44.8/17.7 = 2.6$ . This means that at least three inlets are needed to prevent plugholing.

$$V_e = 44.8/3 = 14.93 \text{ m}^3/\text{s}$$

$$S_{min} = 0.9V_e^{1/2} = 0.9(14.93)^{1/2} = 3.48 \text{ m}$$

$$V_e = 44.8/3 = 14.93 \text{ m}^3/\text{s}$$

$$S_{min} = 0.9V_e^{1/2} = 0.9(14.93)^{1/2} = 3.48 \text{ m}$$

An inlet velocity of 7.5 m/s is chosen. The area of each inlet is  $14.93/7.5 = 1.99 \text{ m}^2$ .

An inlet size of 1.3 by 1.53 m is chosen, and  $D_i = 2ab/(a + b) = 2(1.3)(1.53)/(1.3 + 1.53) = 1.41 \text{ m}$ .

Then  $d/D_i = 3.2/1.41 = 2.27$ , which meets the stipulation that this ratio has to be greater than 2.

These calculations indicate that the edges of the inlets need to be at least 3.48 m apart from each other, and at least  $2D_i$  ( $2 \times 1.41 = 2.82 \text{ m}$ ) from the nearest wall. If the edges of any inlets are closer to a wall, the calculations should be repeated with  $\gamma = 0.5$ . If the inlets were in the walls,  $\gamma$  would be 0.5.

### Zone Fire Modeling

Zone fire modeling is a simple approach to simulating smoke transport. The idea of the zone fire model came from observations in early room fire experiments that a smoke plume rises above the fire, and a smoke layer forms under the ceiling. As the fire continues, the smoke layer descends, and smoke may flow out of doorways (a doorjet).

A zone fire model considers a fire compartment to be made up of an upper smoke layer and a lower nonsmoke layer. The mass flows of the smoke plume and the doorjet are calculated from empirical equations. For the zone model idealization, temperature and concentrations of constituents are considered to be constant throughout each layer. These properties change only as a function of time.

Most zone models consider that ceilings are flat and that rooms have uniform cross-sectional areas. The height of the discontinuity between these layers (the **smoke layer interface**) is considered to be the same everywhere. In the idealized model at an infinitesimal distance above the interface, the temperature and contaminant concentrations are those of the smoke layer. At an infinitesimal distance below the interface, the temperature and contaminant concentrations are those of the lower layer. Even with these simplifications, zone fire models have proven to be very useful tools for many applications, but they must be used with care. Because different zone models use different empirical equations implemented in different ways, the predictions of different zone models vary to some extent.

Many zone models were developed in the 1980s, and often had poor numerical convergence. CFAST is a multiroom zone fire model that has superior numerical convergence, many features, and a graphical interface (Peacock et al. 2017), and has been verified with full-scale fire data. CFAST and its documentation are available from NIST at no cost from [pages.nist.gov/cfast](http://pages.nist.gov/cfast). Probably for these reasons, CFAST has become the de facto standard zone fire model.

CFAST can be used to simulate atrium smoke filling, and is useful for calculating sprinkler activation time. To help new users of this model get started, Chapter 18 of the *Smoke Control Handbook*

has general information about zone models plus some CFAST user information.

### CFD Modeling

Atrium smoke control can be analyzed by CFD modeling. For general information about CFD modeling, see Chapter 13 of the 2017 *ASHRAE Handbook—Fundamentals*. For information about fire applications of CFD modeling, see Chapter 20 of the *Smoke Control Handbook*.

The idea of CFD is to divide the space of interest into a large number of cells and to solve the governing equations for each cell. Often, millions of cells are necessary for atrium applications. The number of cells in the model should be large enough to simulate airflows around modeled obstructions faithfully, and this can be evaluated by a sensitivity analysis of cell size. Obstructions such as walls, balconies, and stairs should be taken into account, and conditions at the boundaries defined. Exhaust flow at or near the top of the atrium is specified, and makeup air conditions are also defined. This allows simulation of fluid flow in considerable detail.

Although CFD modeling has significant advantages in realistically simulating smoke flow, it is computationally intensive and requires a lot of computer memory and time; it is not uncommon for a CFD simulation to run for many hours and sometimes days. CFD produces so many numbers that graphical methods are needed to understand both general trends in the atrium and nuances in localized conditions.

Several general-purpose CFD models are commercially available that can be used for atrium smoke control. NIST has developed the Fire Dynamics Simulator (FDS) model (McGrattan et al. 2019) with visualization software called Smokeview (Forney 2019). FDS, specifically developed and verified for fire applications, can be obtained from NIST at no cost ([pages.nist.gov/fds-smv/](http://pages.nist.gov/fds-smv/)) and has become the de facto standard CFD model for fire applications.

## 15. TENABILITY SYSTEMS

The smoke control systems previously discussed are conventional systems intended either to keep smoke away from occupants or to allow only incidental smoke contact deemed to be negligible. Tenability systems are different: they are designed to allow occupants to come into contact with smoke provided that a tenable environment (i.e., one in which combustion products, including heat, are limited to a level that is not life threatening) is maintained. Analysis of a tenability system consists of a smoke transport analysis and a tenability evaluation.

### Tenability Evaluation

Toxic gas, heat, and thermal radiation exposure are direct threats to life, the severity of which depends on the intensity and duration of exposure. Tenability evaluation considers the effects of exposure to these threats, as well as reduced visibility.

Reduced visibility does not directly threaten life, but it is an indirect hazard. It can reduce walking speed; also, when occupants and firefighters cannot see well, they can become disoriented and cannot get away from the smoke, thus prolonging their exposure. Another concern is that a disoriented person can fall from an atrium balcony, which can be fatal.

For information about calculating the effects of exposures to combustion gases and reduced visibility, see Chapter 6 of the *Smoke Control Handbook*. There is no broad consensus, but suggested visibility criteria range from 4 to 14 m. When combustion products from most materials are diluted enough to meet such visibility criteria, the hazards to life from toxic gases, heat, and thermal radiation are also eliminated for exposures up to 20 min. This means that, for

most fires, tenability can be evaluated by calculating visibility, but the hazards of other exposures must also be checked.

**CFD Models.** CFD models have been used extensively to analyze smoke transport for tenability systems in atriums. In addition to analysis of smoke transport, the FDS model incorporates features that help evaluate tenability. An especially useful feature is the ability of FDS to calculate visibility at user-selected points.

**Large Multi-Compartmented Buildings.** It is not practical to use CFD to simulate smoke transport in large buildings, but CONTAM can handle this simulation in extremely large buildings. With CONTAM, the user inputs the temperatures, and zone fire models can be used to evaluate fire produced temperatures in building spaces. Chapter 19 of the *Smoke Control Handbook* discusses tenability analysis using CONTAM, including an example.

## 16. COMMISSIONING AND TESTING

Commissioning refers to the process of examining, comparing, testing, and documenting the installation and performance of a smoke control system to ensure that it functions according to an approved design. It demonstrates to an owner that the smoke control system installed in a project meets the project's design goals.

Special inspections are a means that an **authority having jurisdiction (AHJ)** uses to determine that a smoke control system meets the code requirements. The International Building Code (IBC) has requirements for a special inspection and describes the qualifications required for a special inspector (ICC 2012).

### Commissioning Process

Commissioning begins at the start of the project and continues throughout the project. ASHRAE *Guideline* 1.5 provides methods for verifying and documenting that the performance of smoke control systems conforms with the intent of the design. For smoke control systems, an AHJ such as a building official or fire marshal typically enforces a combination of building codes, fire codes, and local standards. The intent is to determine that the system meets the owner's project requirements (OPR), including code requirements and inspections by the AHJ throughout the delivery of the project.

Witnessing and reporting are important parts of commissioning. For successful commissioning of a system, several different people typically are involved in the process. In addition to the building owner and AHJ, the system designer, general contractor, subcontractors, fire protection engineering consultants, and testing and balancing technicians can be involved. At the end of testing, documentation is provided that the system is working properly according to the design.

Commissioning activities can occur at multiple stages during the construction process. Duct inspections, duct leakage testing, and barrier inspections are activities that typically occur early in the construction process when the ducts and barriers are readily visible. Component testing, including airflow measurement, can occur at a midpoint in construction where power is provided to individual devices, but central monitoring and control has not yet been provided. Sequence of operations and final performance testing typically occurs when construction is nearly complete, often just before the building is intended to obtain its permits and open to the public.

### Commissioning Testing

Commonly, testing and balancing (TAB) is required before formal acceptance testing to achieve the expected performance of all the components. TAB refers to the process where the as-built performance of smoke control systems is tested in the field and compared to the required design conditions. Adjustments to the installed system, such as refining the supply airflow rates, are made to ensure that the smoke control system is functioning as intended in the approved design documentation.

System performance testing is the phase where the code-specified performance parameters appropriate to the smoke control design are measured. For example, building codes require that a minimum pressure difference exist between a pressurized stairwell and other zones in the building, and that door-opening force must not exceed a specified amount. In this case, performance testing would focus on measuring the pressure difference across stairwell doors and door-opening forces. Some common parameters measured during smoke control system performance testing are (1) exhaust/supply airflow quantities, (2) airflow velocities at atrium or other large open space perimeters, (3) door-opening forces, and (4) pressure differences between zones.

**Caution: Smoke Bomb Tests Not Recommended.** Artificial smoke from smoke bombs (also called smoke candles) or any kind of artificial smoke generator is not recommended for any performance testing, because it lacks the buoyancy of hot smoke from a real building fire. Smoke near a flaming fire has a temperature in the range of 540 to 1100°C. Heating chemical smoke to such temperatures to emulate smoke from a real fire is not recommended unless precautions are taken to protect life and property.

### Special Inspector

Some building codes require special inspections and tests of smoke control systems in addition to the ordinary inspection and test requirements for buildings, structures, and parts of buildings. These special inspections and tests should verify the proper commissioning of the smoke control design in its final, installed condition. Procedures for inspection and testing should be developed by the smoke control system's special inspector, with approval of the authorities having jurisdiction. The special inspector must understand the principles of smoke control, including code requirements, and should check that the system's components are as specified and are installed as intended, as well as whether the smoke control system performs as intended.

### Periodic Testing

After a smoke control system has been commissioned, testing must still be performed periodically over the building's life to ensure the system is in proper operating condition in the event of a fire. Periodic testing includes manual testing involving ongoing inspection and maintenance, and automatic testing to determine that integral equipment is functional and operational. Automatic testing is often performed at a higher frequency than manual testing. Continued inspection and testing identifies adjustments and repairs needed to account for unforeseen changes to the building or failure of components.

Until recently, smoke control system reliability has been somewhat compromised because periodic testing was limited to manual testing. Inspections performed years after commissioning showed that some smoke control systems were inoperable, turned off, or made ineffective by modifications to equipment or the building. Reliability of smoke control systems should be significantly improved by using automatic weekly self testing of system components, available from Underwriters Laboratories (UL) listed equipment with the UUKL product designation.

Dampers that are part of code-mandated passive smoke barriers are not included in the automatic weekly self testing. Typically, codes require testing these dampers every four years, except in hospitals (every six years).

## 17. EXTRAORDINARY INCIDENTS

Most buildings are designed and built to be protected from ordinary incidents, but some buildings need protection from extraordinary incidents. Extraordinary incidents, whether caused by war, terrorism, accident, or natural disaster, can affect immediate human



needs such as survival and safety, and also longer-term needs such as air, water, food, and shelter. Some buildings are designed with specific features intended to make them less susceptible to extraordinary incidents. It is recommended that actuation of systems for fire and smoke protection be of higher priority than possibly conflicting automatic strategies designed to respond to other extraordinary conditions.

Some acts of terrorism use fire, and those using bombs often lead to fires. It is well known that war, terrorist attacks, and natural disasters have the potential to disrupt utilities and interfere with firefighting, and this often allows any fires that occur to grow unchecked. For these reasons, simultaneous fire and other extraordinary incidents should be considered likely, and any features intended to mitigate extraordinary conditions should be designed accordingly. For more information, see ASHRAE's (2003) report, *Risk Management Guidance for Health, Safety and Environmental Security under Extraordinary Incidents*, and Chapter 61 of this volume.

## 18. SYMBOLS

$A$	= area, m <sup>2</sup>
$a$	= dilution rate, air changes per minute; length of inlet, m
$A_a$	= free area around elevator car, m <sup>2</sup>
$A_{BO}$	= flow area per stairwell between building and outdoors, m <sup>2</sup>
$A_e$	= effective area, m <sup>2</sup>
$A_i$	= flow area of path $i$ , m <sup>2</sup>
$A_{lr}$	= leakage area between building and lobby, m <sup>2</sup>
$A_s$	= cross-sectional area of shaft, m <sup>2</sup>
$A_{SB}$	= flow area between stairwell and building, m <sup>2</sup>
$A_w$	= area of ventilation opening, m <sup>2</sup>
$b$	= distance from opening to balcony edge, m; width of inlet, m
$C$	= flow coefficient; concentration of contaminant at time $t$
$C_c$	= flow coefficient for flow around car
$C_O$	= initial concentration of contaminant
$C_p$	= specific heat of plume gases, 1.0 kJ/(kg·K)
$C_w$	= pressure coefficient
$d$	= depth of smoke layer below lowest point of exhaust inlet, m; distance from doorknob to knob side of door, m
$D_i$	= diameter of exhaust inlet, m
$F$	= total door-opening force, kg
$F_{dc}$	= door closer force, kg
$F_R$	= flow area factor
$H$	= floor-to-ceiling height, m; height of balcony above fuel, m
$H_J$	= thickness of ceiling jet, m
$H_m$	= height limit, m
$H_w$	= height of ventilation opening, m
$K$	= fraction of convective heat release contained in smoke layer
$m$	= mass flow rate, m <sup>2</sup> /s
$p_{atm}$	= atmospheric pressure, Pa
$p_w$	= wind pressure, Pa
$q$	= heat release rate, kW/s
$q_c$	= convective heat release rate, kW/s
$R$	= gas constant, 287 J/(kg·K)
$S_{min}$	= minimum edge-to-edge separation between inlets, m
$t$	= time, s
$T_B$	= temperature in building, °C; absolute temperature in building, K
$T_F$	= absolute temperature of fire compartment, K
$t_g$	= growth time, s
$T_{in}$	= absolute temperature of air into fire compartment, K
$T_J$	= absolute temperature of ceiling jet, K
$T_O$	= temperature of outdoors, °C or K
$T_o$	= absolute ambient temperature, °C or K
$T_{out}$	= absolute temperature of smoke leaving fire compartment, K
$T_S$	= temperature of shaft or stairwell, °C or K
$T_s$	= absolute temperature of smoke, K
$U$	= elevator car velocity, m/s
$U_H$	= velocity at wall height $H$ , m/s
$V$	= volumetric flow rate, m <sup>3</sup> /s
$V_e$	= volumetric flow rate of one exhaust inlet, m <sup>3</sup> /s
$V_{in}$	= volumetric flow rate of air into fire compartment, m <sup>3</sup> /s
$V_{max}$	= maximum volumetric flow rate without plugholing at $T_s$ , m <sup>3</sup> /s

$V_{out}$	= volumetric flow rate of smoke out of fire compartment, m <sup>3</sup> /s
$W$	= door width or width of spill, m
$w$	= width of opening from area of origin, m
$z$	= distance above neutral plane or distance above base of fire, m
$z_b$	= height of plume above balcony edge, m
$z_l$	= limiting elevation, m

## Greek

$\gamma$	= exhaust location factor
$\Delta p$	= pressure difference, Pa
$\Delta p_{FS}$	= pressure difference from fire compartment to surroundings, Pa
$\Delta p_{max}$	= maximum design pressure difference, Pa
$\Delta p_{min}$	= minimum design pressure difference, Pa
$\Delta p_{SO}$	= pressure difference from shaft to outdoors, Pa
$\Delta p_{u,si}$	= upper limit pressure difference from shaft to building, Pa
$\eta$	= heat transfer factor
$\rho$	= density, kg/m <sup>3</sup>
$\rho_o$	= outdoor air density, kg/m <sup>3</sup>
$\chi_c$	= convective fraction

## REFERENCES

- ASHRAE members can access *ASHRAE Journal* articles and ASHRAE research project final reports at [technologyportal.ashrae.org](http://technologyportal.ashrae.org). Articles and reports are also available for purchase by nonmembers in the online ASHRAE Bookstore at [www.ashrae.org/bookstore](http://www.ashrae.org/bookstore).
- Achakji, G.Y., and G.T. Tamura. 1988. Pressure drop characteristics of typical stairshafts in high-rise buildings. *ASHRAE Transactions* 94(1):1223-1237. Paper DA-88-13-2.
- Ahrens, M. 2017. U.S. experience with sprinklers. Report, National Fire Protection Association, Quincy, MA. [www.nfpa.org/-/media/Files/News-and-Research/Fire-statistics-and-reports/Suppression/ossprinklers.pdf](http://www.nfpa.org/-/media/Files/News-and-Research/Fire-statistics-and-reports/Suppression/ossprinklers.pdf).
- ASHRAE. 2003. Risk management guidance for health, safety and environmental security under extraordinary incidents. Report, Presidential Ad Hoc Committee for Building Health and Safety under Extraordinary Incidents.
- ASHRAE. 2012. Commissioning smoke management systems. *ASHRAE Guideline* 1.5-2012.
- ASHRAE. 2013. Laboratory methods of testing fans used to exhaust smoke in smoke management systems. ANSI/ASHRAE *Standard* 149-2013.
- ASTM. 2017. Test method for fire tests of penetration firestop systems. *Standard* E814-13a (2017). American Society for Testing and Materials, West Conshohocken, PA.
- Cresci, R.J. 1973. Smoke and fire control in high-rise office buildings—Part II, Analysis of stair pressurization systems. Symposium on Experience and Applications on Smoke and Fire Control, ASHRAE Annual Meeting, June.
- CSI. 2018. *MasterFormat: Master list of numbers and titles for the construction industry*. Construction Specifications Institute, Alexandria, VA. [www.masterformat.com](http://www.masterformat.com).
- Dols, W.S., and B.J. Polidoro. 2016. CONTAM user guide and program documentation version 3.2. NIST *Technical Note* 1887. National Institute of Standards and Technology, Gaithersburg, MD.
- Fang, J.B. 1980. Static pressures produced by room fires. NBSIR *Publication* 80-1984. National Bureau of Standards. Available from National Institute of Standards and Technology, Gaithersburg, MD.
- Felker, L.G., and T.L. Felker. 2009. *Dampers and airflow control*. ASHRAE.
- Forney, G.P. 2017. User's guide for Smokeview—A tool for visualizing fire dynamics simulation data, 6th ed. NIST *Special Publication* 1017-1, National Institute of Standards and Technology, Gaithersburg, MD.
- Hadjisophocleous, G.V., and J. Zhou. 2008. Evaluation of atrium smoke exhaust make-up air velocity (RP-1300). *ASHRAE Transactions* 114(1):147-153. Paper NY-08-020.
- ICC. 2012. *International Building Code*®. International Code Council, Washington, DC, Section 909.
- Klote, J.H. 1988. Analysis of the influence of piston effect on elevator smoke control. NBSIR *Publication* 88-3751, National Institute of Standards and Technology, Gaithersburg, MD.
- Klote, J.H. 2004. Tenability and open doors in pressurized stairwells (RP-1203). *ASHRAE Transactions* 110(1). Paper AN-04-11-1.
- Klote, J.H. 2014. *AtriumCalc: Atrium smoke control calculator—Technical information and user guide*, v. 1.1. ASHRAE.

- Klote, J.H. 2018. A new look at door-opening forces and smoke control. *ASHRAE Conference Paper* HO-18-C033.
- Klote, J.H., and X. Bodart. 1985. Validation of network models for smoke control analysis. *ASHRAE Transactions* 91(2B):1134-1145. *Paper* HI-85-23-2.
- Klote, J.H., and G. Tamura. 1986. Elevator piston effect and the smoke problem. *Fire Safety Journal* 11(2):227-233.
- Klote, J.H., and G. Tamura. 1987. Experiments of piston effect on elevator smoke control. *ASHRAE Transactions* 93(2A):2217-2228. *Paper* NT-87-26-1.
- Klote, J. H., J.A. Milke, P.G. Turnbull, A. Kashef, and M.J. Ferreira. 2012. *Handbook of smoke control engineering*. ASHRAE.
- Klote, J.H., P.G. Turnbull, and D.H. Evans. 2017. Pressurized stairwells with open doors and the IBC. *ASHRAE Conference Paper* LB-17-C026.
- Ko, Y.J., and G.D. Lougheed. 2016. Performance of stairwell pressurization system with open doors (RP-1447). *ASHRAE Transactions* 122(2). *Paper* ST-16-003.
- Ko, Y., G. Hadjisophocleous, and G.D. Lougheed. 2008. CFD study of the air entrainment of balcony spill plumes at the balcony edge (RP-1247). *ASHRAE Transactions* 114(1). *Paper* NY-08-040.
- Law, M. 1986. A note on smoke plumes from fires in multilevel shopping malls. *Fire Safety Journal* 10(3).
- Lougheed, G.D. 1997. Expected size of shielded fires in sprinklered office buildings (RP-838). *ASHRAE Transactions* 103(1). *Paper* PH-97-02-1.
- Lougheed, G.D., and C. McCartney. 2008a. Balcony spill plumes: Full-scale experiments, part 1 (RP-1247). *ASHRAE Transactions* 114(1). *Paper* NY-08-039.
- Lougheed, G.D., and C. McCartney. 2008b. Balcony spill plumes: Full-scale experiments, part 2 (RP-1247). *ASHRAE Transactions* 114(1). *Paper* NY-08-041.
- Lougheed, G.D., C.J. McMort, and E. Gibbs. 2007. Balcony spill plumes. ASHRAE Research Project RP-1247, *Final Report*.
- Madrzykowski, D., and R.L. Vettori. 1992. A sprinkler fire suppression algorithm for the GSA engineering fire assessment system. NISTIR *Publication* 4833, National Institute of Standards and Technology, Gaithersburg, MD.
- McCartney, C., G.D. Lougheed, and E.J. Weckman. 2008. CFD investigation of balcony spill plumes in atria. *ASHRAE Transactions* 114(1).
- McGrattan, K., R. McDermott, C. Weinschenk, K. Overholt, S. Hostikka, and J. Floyd. 2017. Fire dynamics simulator user's guide. NIST *Special Publication* 1019, 6th Edition. National Institute of Standards and Technology, Gaithersburg, MD.
- Morgan, H.P., and G.O. Hansell. 1987. Atrium buildings: Calculating smoke flows in atria for smoke control design. *Fire Safety Journal* 12:9-12.
- Morgan, H.P., and N.R. Marshall. 1979. Smoke control measures in covered two-story shopping malls having balconies and pedestrian walkways. BRE CP *Publication* 11/79, Borehamwood, U.K.
- NFPA. 2018. Standard for smoke control systems. *Standard* 92. National Fire Protection Association, Quincy, MA.
- NFPA. 2018. Life safety code®. *Standard* 101. National Fire Protection Association, Quincy, MA.
- NFPA. 2018. Standard for smoke and heat venting. *Standard* 204. National Fire Protection Association, Quincy, MA.
- Peacock, R.D., P.A. Reneke, and G.P. Forney. 2015. CFAST—Consolidated model of fire growth and smoke transport (version 7) volume 2: User's guide. NIST *Technical Note* 1889v2. National Institute of Standards and Technology, Gaithersburg, MD. [dx.doi.org/10.6028/NIST.TN.1889v2](https://dx.doi.org/10.6028/NIST.TN.1889v2).
- Pongratz, C., J.A. Milke, and A. Trouve. 2016. A CFD study to identify methods to increase maximum velocity of makeup air for atrium smoke control (RP-1600). *ASHRAE Transactions* 122(2). *Paper* ST-16-002.
- SFPE. 2016. *SFPE Handbook of fire protection engineering*, 5th ed. Society of Fire Protection Engineers, Bethesda, MD.
- Shaw, C.Y., J.T. Reardon, and M.S. Cheung. 1993. Changes in air leakage levels of six Canadian office buildings. *ASHRAE Journal* 35(2):34-36.
- Tamura, G.T. 1990. Fire tower tests of stair pressurization systems with overpressure relief (RP-559). *ASHRAE Transactions* 96(2). *Paper* 3426.
- Tamura, G.T., and C.Y. Shaw. 1976a. Studies on exterior wall air tightness and air infiltration of tall buildings. *ASHRAE Transactions* 83(1):122-134. *Paper* DA-2388.
- Tamura, G.T., and C.Y. Shaw. 1976b. Air leakage data for the design of elevator and stair shaft pressurization systems. *ASHRAE Transactions* 83(2): 179-190. *Paper* SE-2413.
- Tamura, G.T., and C.Y. Shaw. 1978. Experimental studies of mechanical venting for smoke control in tall office buildings. *ASHRAE Transactions* 86(1):54-71. *Paper* AT-2472.
- Tamura, G.T., and A.G. Wilson. 1966. Pressure differences for a 9-story building as a result of chimney effect and ventilation system operation. *ASHRAE Transactions* 72(1):180-189.
- UL. 2006. Fire dampers. ANSI/UL *Standard* 555. Underwriters Laboratories, Northbrook, IL.
- UL. 2014. Safety for ceiling dampers. ANSI/UL *Standard* 555C. Underwriters Laboratories, Northbrook, IL.
- UL. 2014. Smoke dampers. ANSI/UL *Standard* 555S. Underwriters Laboratories, Northbrook, IL.
- UL. 2015. Fire tests of penetration firestops. ANSI/UL *Standard* 1479-10. Underwriters Laboratories, Northbrook, IL.
- Zhou, J., and G.V. Hadjisophocleous. 2008. Parameters affecting fire plumes (RP-1300). *ASHRAE Transactions* 114(1):140-146.



## ویدیو - انیمیشن های اطفاء، اعلام حریق، تهویه و تخلیه دود (رایگان)

برای مشاهده هر یک از ویدیوهای زیر کافیست بر روی عنوان آن آموزش کلیک نمایید تا به صفحه ویدیو و آموزش آن عنوان هدایت شوید.

### انیمیشن ویدیو

#### • اطفاء حریق آبی

- [سیستم اطفاء لوله خشک اسپرینکلر](#)
- [سیستم اطفاء لوله تر اسپرینکلر](#)
- [سیستم اطفاء پیش عملگر](#)
- [سیستم اطفاء واترمیست](#)
- [سیستم اطفاء سیلابی](#)

#### • سیستم اطفاء فوم

#### • تجهیزات اطفاء حریق - تجهیزات هشدار دهنده

#### • تجهیزات اطفاء حریق - اسپرینکلر

#### • سیستم اطفاء آشپزخانه صنعتی

#### • سیستم اطفاء آبروسل

#### • سیستم اطفاء دستی

#### • سیستم اطفاء گازی

#### ○ [سیستم اطفاء FM200 , NOVEC, Inert Gas \(IG\)](#)

#### ○ [سیستم اطفاء CO<sub>2</sub>](#)

#### • [سیستم تهویه و تخلیه دود](#)

#### • [سیستم اعلام حریق](#)

#### ○ [آدرس پذیر](#)

#### ○ [متعارف](#)



### آموزش استاندارد

- [آموزش استاندارد NFPA 13](#)
- [آموزش استاندارد NFPA 14](#)
- [آموزش استاندارد NFPA 20](#)

### آموزش نرم افزار

- [اتواسپرینک](#)
- [پایروسیم](#)
- [پت فایندر](#)

### دانلود استاندارد

- [ترجمه استاندارد NFPA 30,14,13,10](#)
- [تمامی استانداردهای NFPA & FM](#)
- [ترجمه استاندارد NFPA 1037](#)

### محصولات

- [اتواسپرینک ۲۰۱۳ و ۲۰۱۹ به زبان فارسی برای اولین بار در ایران](#)
- [آلارم کد ۲۰۱۹ به زبان فارسی برای اولین بار در ایران](#)
- [اطفا حریق آبی](#)
- [پایپنت \(ماژول اسپرینکلر\)](#)
- [کانتم](#)
- [اعلان حریق](#)

### دوره‌های حضوری

- آموزش اتواسپرینک
- آموزش آلارم کد
- آموزش پایروسیم
- آموزش کانتم + اگزاست
- آموزش اطفا آبی + پمپ + بازدید از کارگاه
- آموزش اطفا گازی
- آموزش اطفا فوم
- آموزش مبحث سوم مقررات ملی
- آموزش اعلام حریق F&G
- آموزش اعلام حریق آدرس پذیر
- آموزش اعلام حریق متعارف
- دوره آمادگی آزمون آتش نشانی (برق، مکانیک، عمران، معماری)





## دوره های آموزشی

ارائه تخفیف جهت خرید نرم افزارها

ارائه کد تخفیف جهت شرکت در دوره های آموزشی



EDUFIRE.IR

طراحی تهویه  
و تخلیه دود همراه با  
آموزش نرم افزار  
Contam

کد آموزشی ۱۰۴

۱۶ ساعت

میانی و شناخت پمپ  
بوسترپمپ های آبرسانی  
و آتش نشانی به همراه  
بازدید از خط تولید

کد آموزشی ۱۰۳

۱۶ ساعت

طراحی اعلام حریق  
Addressable  
Conventional

کد آموزشی ۱۰۲

۱۶ ساعت

طراحی اطفاء حریق  
آبی با نرم افزار  
AutoSPRINKY۰۱۹

کد آموزشی ۱۰۱

۱۶ ساعت

طراحی اطفاء حریق  
گازی  
FM200 & NOVEC  
CO<sub>2</sub>

کد آموزشی ۱۰۸

۱۶ ساعت

طراحی اطفاء حریق  
و آشنایی با ضوابط  
سازمان آتش نشانی

کد آموزشی ۱۰۷

۱۶ ساعت

طراحی اطفاء حریق  
فوم

کد آموزشی ۱۰۶

۱۶ ساعت

طراحی سیستم اعلان  
آدرس پذیر همراه با  
آموزش نرم افزار  
AlarmCAD

کد آموزشی ۱۰۵

۱۶ ساعت

طراحی استخر، سونا  
و جکوزی

کد آموزشی ۱۱۲

۱۶ ساعت

آمادگی آزمون  
آتش نشانی  
مکانیک - برق  
عمران - معماری

کد آموزشی ۱۱۱

۱۶ ساعت

طراحی با نرم افزار  
Pyrosim

کد آموزشی ۱۱۰

۱۶ ساعت

آموزش مبحث سوم  
مقررات ملی ساختمان

کد آموزشی ۱۰۹

۳۲ ساعت



آموزشگاه ادوفایر  
**EDUFIRE**

All **NFPA & FM** STANDARDS

 **EDUFIRE\_NFPA**

 **EDUFIRE.IR**

 **Latest Version**

**FREE**

    
**EDUFIRE.IR**

