

NFPA[®]

1145

**Guide for the Use of Class A
Foams in Fire Fighting**

2017



All **NFPA** STANDARDS

 **EDUFIRE_NFPA**

 **EDUFIRE.IR**

FREE
2019



IMPORTANT NOTICES AND DISCLAIMERS CONCERNING NFPA® DOCUMENTS

NOTICE AND DISCLAIMER OF LIABILITY CONCERNING THE USE OF NFPA DOCUMENTS

NFPA® codes, standards, recommended practices, and guides (“NFPA Standards”), of which the document contained herein is one, are developed through a consensus standards development process approved by the American National Standards Institute. This process brings together volunteers representing varied viewpoints and interests to achieve consensus on fire and other safety issues. While the NFPA administers the process and establishes rules to promote fairness in the development of consensus, it does not independently test, evaluate, or verify the accuracy of any information or the soundness of any judgments contained in NFPA Standards.

The NFPA disclaims liability for any personal injury, property or other damages of any nature whatsoever, whether special, indirect, consequential or compensatory, directly or indirectly resulting from the publication, use of, or reliance on NFPA Standards. The NFPA also makes no guaranty or warranty as to the accuracy or completeness of any information published herein.

In issuing and making NFPA Standards available, the NFPA is not undertaking to render professional or other services for or on behalf of any person or entity. Nor is the NFPA undertaking to perform any duty owed by any person or entity to someone else. Anyone using this document should rely on his or her own independent judgment or, as appropriate, seek the advice of a competent professional in determining the exercise of reasonable care in any given circumstances.

The NFPA has no power, nor does it undertake, to police or enforce compliance with the contents of NFPA Standards. Nor does the NFPA list, certify, test, or inspect products, designs, or installations for compliance with this document. Any certification or other statement of compliance with the requirements of this document shall not be attributable to the NFPA and is solely the responsibility of the certifier or maker of the statement.

REMINDER: UPDATING OF NFPA STANDARDS

Users of NFPA codes, standards, recommended practices, and guides (“NFPA Standards”) should be aware that NFPA Standards may be amended from time to time through the issuance of Tentative Interim Amendments or corrected by Errata. An official NFPA Standard at any point in time consists of the current edition of the document together with any Tentative Interim Amendment and any Errata then in effect.

In order to determine whether an NFPA Standard has been amended through the issuance of Tentative Interim Amendments or corrected by Errata, visit the Document Information Pages on NFPA’s website. The Document Information Pages provide up-to-date, document specific information including any issued Tentative Interim Amendments and Errata.

To access the Document Information Page for a specific NFPA Standard, go to <http://www.nfpa.org/docinfo> to choose from the list of NFPA Standards or use the search feature on the right to select the NFPA Standard number (e.g., NFPA 101). The Document Information page includes postings of all existing Tentative Interim Amendments and Errata. It also includes the option to register for an “Alert” feature to receive an automatic email notification when new updates and other information are posted regarding the document.

ISBN: 978-145591431-9 (Print)

ISBN: 978-145591432-6 (PDF)

IMPORTANT NOTICES AND DISCLAIMERS CONCERNING NFPA® STANDARDS

ADDITIONAL NOTICES AND DISCLAIMERS

Updating of NFPA Standards

Users of NFPA codes, standards, recommended practices, and guides (“NFPA Standards”) should be aware that these documents may be superseded at any time by the issuance of new editions or may be amended from time to time through the issuance of Tentative Interim Amendments or corrected by Errata. An official NFPA Standard at any point in time consists of the current edition of the document together with any Tentative Interim Amendments and any Errata then in effect. In order to determine whether a given document is the current edition and whether it has been amended through the issuance of Tentative Interim Amendments or corrected through the issuance of Errata, consult appropriate NFPA publications such as the National Fire Codes® Subscription Service, visit the NFPA website at www.nfpa.org, or contact the NFPA at the address listed below.

Interpretations of NFPA Standards

A statement, written or oral, that is not processed in accordance with Section 6 of the Regulations Governing the Development of NFPA Standards shall not be considered the official position of NFPA or any of its Committees and shall not be considered to be, nor be relied upon as, a Formal Interpretation.

Patents

The NFPA does not take any position with respect to the validity of any patent rights referenced in, related to, or asserted in connection with an NFPA Standard. The users of NFPA Standards bear the sole responsibility for determining the validity of any such patent rights, as well as the risk of infringement of such rights, and the NFPA disclaims liability for the infringement of any patent resulting from the use of or reliance on NFPA Standards.

NFPA adheres to the policy of the American National Standards Institute (ANSI) regarding the inclusion of patents in American National Standards (“the ANSI Patent Policy”), and hereby gives the following notice pursuant to that policy:

NOTICE: The user’s attention is called to the possibility that compliance with an NFPA Standard may require use of an invention covered by patent rights. NFPA takes no position as to the validity of any such patent rights or as to whether such patent rights constitute or include essential patent claims under the ANSI Patent Policy. If, in connection with the ANSI Patent Policy, a patent holder has filed a statement of willingness to grant licenses under these rights on reasonable and nondiscriminatory terms and conditions to applicants desiring to obtain such a license, copies of such filed statements can be obtained, on request, from NFPA. For further information, contact the NFPA at the address listed below.

Law and Regulations

Users of NFPA Standards should consult applicable federal, state, and local laws and regulations. NFPA does not, by the publication of its codes, standards, recommended practices, and guides, intend to urge action that is not in compliance with applicable laws, and these documents may not be construed as doing so.

Copyrights

NFPA Standards are copyrighted. They are made available for a wide variety of both public and private uses. These include both use, by reference, in laws and regulations, and use in private self-regulation, standardization, and the promotion of safe practices and methods. By making these documents available for use and adoption by public authorities and private users, the NFPA does not waive any rights in copyright to these documents.

Use of NFPA Standards for regulatory purposes should be accomplished through adoption by reference. The term “adoption by reference” means the citing of title, edition, and publishing information only. Any deletions, additions, and changes desired by the adopting authority should be noted separately in the adopting instrument. In order to assist NFPA in following the uses made of its documents, adopting authorities are requested to notify the NFPA (Attention: Secretary, Standards Council) in writing of such use. For technical assistance and questions concerning adoption of NFPA Standards, contact NFPA at the address below.

For Further Information

All questions or other communications relating to NFPA Standards and all requests for information on NFPA procedures governing its codes and standards development process, including information on the procedures for requesting Formal Interpretations, for proposing Tentative Interim Amendments, and for proposing revisions to NFPA standards during regular revision cycles, should be sent to NFPA headquarters, addressed to the attention of the Secretary, Standards Council, NFPA, 1 Batterymarch Park, P.O. Box 9101, Quincy, MA 02269-9101; email: stds_admin@nfpa.org

For more information about NFPA, visit the NFPA website at www.nfpa.org. All NFPA codes and standards can be viewed at no cost at www.nfpa.org/freeaccess.

Copyright © 2016 National Fire Protection Association®. All Rights Reserved.

NFPA® 1145

Guide for the

Use of Class A Foams in Fire Fighting

2017 Edition

This edition of NFPA 1145, *Guide for the Use of Class A Foams in Fire Fighting*, was prepared by the Technical Committee on Wildland Fire Management. It was issued by the Standards Council on May 13, 2016, with an effective date of June 2, 2016, and supersedes all previous editions.

This edition of NFPA 1145 was approved as an American National Standard on June 2, 2016.

Origin and Development of NFPA 1145

At the request of the NFPA Standards Council in 1998, the Technical Committee on Forest and Rural Fire Protection developed NFPA 1145, *Guide for the Use of Class A Foams in Manual Structural Fire Fighting*, as a guide to assist fire departments and wildland fire agencies in the use of Class A foams for structural fire suppression and protection.

The committee initially considered writing a standard on the application of Class A foam. However, because the use of Class A foam and its associated hardware and proportioning systems was still evolving, the committee decided that a guide to the use of such foam would be of greater benefit to the many fire departments and agencies that were exploring the use of Class A foam for structural fire protection as well as fire suppression and extinguishment.

The second edition of NFPA 1145, in 2006, reorganized the document in accordance with the *Manual of Style for NFPA Technical Committee Documents*, updated definitions as appropriate to use the preferred definition, and editorially updated and expanded the text to continue to make the document more useful to the reader. References to additional materials that could aid the reader in using Class A foam were also added.

The 2011 edition of NFPA 1145 included additional references to research and guidance available from government and private sources, as well as updates to health and safety information for fire fighters.

For the 2017 edition, the technical committee revised NFPA 1145 with a generalized approach to guidance for the use of Class Foam. This resulted in a document title change and a “downsizing” of the scope and purpose statements within the document and material related to foam use. In addition, the title of Chapter 6 has been changed to Operational Considerations.

Technical Committee on Wildland Fire Management

Stephen A. Gage, *Chair*
U.S. Forest Service, ID [E]

Paul Acosta, Colorado State Fire Fighters Association, CO [L]
Rep. National Volunteer Fire Council

Randall K. Bradley, Stanislaus Consolidated Fire Protection District, CA [E]

Frederick R. Flores, CAL FIRE/CA Department of Forestry & Fire Protection, CA [L]
Rep. International Association of Fire Fighters

Donald C. Freyer, Warner Robins, GA [SE]

Charles W. George, ICL Performance Products-Phos-Chek Group, MT [M]
Rep. ICL Performance Products LP

Joseph T. Holland, Hoover Treated Wood Products, FL [M]

Wesley M. Keller, Pennsylvania Bureau of Forestry, PA [U]

Alexander Maranghides, National Institute of Standards & Technology, MD [RT]

Steve Oaks, Santa Barbara County Fire Department, CA [E]

Stephen S. Pollock, Texas A&M Forest Service, TX [E]
Rep. International Association of Fire Chiefs

Jim Prevette, Southern Group of State Foresters, NC [U]

Gene Rogers, Wildland Fire Technologies Inc., OR [SE]

Rob Rosovich, FireIce Inc., FL [M]

Patrick Shipp, Webster Fire Department, TX [E]

Thomas B. Sing, Quest Fire Analysis, TX [SE]

Jim Stumpf, Organizational Quality Associates, ID [SE]

Alternates

Nelson P. Bryner, National Institute of Standards & Technology, MD [RT]
(Alt. to Alexander Maranghides)

Craig M. Daugherty, San Juan County Fire Department, NM [E]
(Alt. to Stephen S. Pollock)

Jeanne Pincha-Tulley, USDA Forest Service, CA [E]
(Alt. to Stephen A. Gage)

Thomas McGowan, NFPA Staff Liaison

Ron Raley, Raley's Forestry and Wildfire, CA [M]
(Alt. to Charles W. George)

Thomas M. Sing, Quest Fire Analysis, TX [SE]
(Alt. to Thomas B. Sing)

Christopher R. Vaughan, Alabama Fire College, AL [L]
(Alt. to Paul Acosta)

This list represents the membership at the time the Committee was balloted on the final text of this edition. Since that time, changes in the membership may have occurred. A key to classifications is found at the back of the document.

NOTE: Membership on a committee shall not in and of itself constitute an endorsement of the Association or any document developed by the committee on which the member serves.

Committee Scope: This committee shall have the primary responsibility for documents on wildland fire management.

Contents

Chapter 1 Administration	1145- 4	Chapter 5 Hardware	1145- 8
1.1 Scope.	1145- 4	5.1 General.	1145- 8
1.2 Purpose.	1145- 4	5.2 Proportioning.	1145- 8
1.3 Foreword.	1145- 4	5.3 Foam Generation and Discharge.	1145- 11
Chapter 2 Referenced Publications	1145- 5	5.4 Check Valves.	1145- 12
2.1 General.	1145- 5	Chapter 6 Operational Considerations	1145- 13
2.2 NFPA Publications.	1145- 5	6.1 General.	1145- 13
2.3 Other Publications.	1145- 5	6.2 Selection of Foam Characteristics and Application Techniques.	1145- 13
2.4 References for Extracts in Advisory Sections.	1145- 5	6.3 Operator Information.	1145- 13
Chapter 3 Definitions	1145- 5	6.4 Routine and Post-Incident System Maintenance.	1145- 13
3.1 General.	1145- 5	6.5 Post-Incident Documentation.	1145- 13
3.2 NFPA Official Definitions.	1145- 5	Chapter 7 Operational Safety	1145- 13
3.3 General Definitions.	1145- 5	7.1 General.	1145- 13
Chapter 4 Properties and Characteristics of Foam Concentrate, Foam Solution, and Finished Foam	1145- 6	7.2 Working Conditions.	1145- 13
4.1 Foam Concentrate.	1145- 6	Annex A Explanatory Material	1145- 14
4.2 Foam Solution.	1145- 7	Annex B Informational References	1145- 15
4.3 Foam.	1145- 7	Index	1145- 17

NFPA 1145

Guide for the

Use of Class A Foams in Fire Fighting

2017 Edition

IMPORTANT NOTE: This NFPA document is made available for use subject to important notices and legal disclaimers. These notices and disclaimers appear in all publications containing this document and may be found under the heading “Important Notices and Disclaimers Concerning NFPA Standards.” They can also be obtained on request from NFPA or viewed at www.nfpa.org/disclaimers.

UPDATES, ALERTS, AND FUTURE EDITIONS: New editions of NFPA codes, standards, recommended practices, and guides (i.e., NFPA Standards) are released on scheduled revision cycles. This edition may be superseded by a later one, or it may be amended outside of its scheduled revision cycle through the issuance of Tentative Interim Amendments (TIAs). An official NFPA Standard at any point in time consists of the current edition of the document, together with all TIAs and Errata in effect. To verify that this document is the current edition or to determine if it has been amended by TIAs or Errata, please consult the National Fire Codes® Subscription Service or the “List of NFPA Codes & Standards” at www.nfpa.org/docinfo. In addition to TIAs and Errata, the document information pages also include the option to sign up for alerts for individual documents and to be involved in the development of the next edition.

NOTICE: An asterisk (*) following the number or letter designating a paragraph indicates that explanatory material on the paragraph can be found in Annex A.

A reference in brackets [] following a section or paragraph indicates material that has been extracted from another NFPA document. As an aid to the user, the complete title and edition of the source documents for extracts in mandatory sections of the document are given in Chapter 2 and those for extracts in informational sections are given in Annex B. Extracted text may be edited for consistency and style and may include the revision of internal paragraph references and other references as appropriate. Requests for interpretations or revisions of extracted text shall be sent to the technical committee responsible for the source document.

Information on referenced publications can be found in Chapter 2 and Annex B.

Chapter 1 Administration

1.1 Scope.

1.1.1 This document presents information for agencies planning to use Class A foam for fire fighting and protection. It presents information on foam properties and characteristics, proportioning and discharge hardware, application techniques, and safety considerations.

1.1.2 This document describes the use and application of Class A foams that meet the requirements of NFPA 1150.

1.1.3 This document does not apply to the use of Class A foam in sprinkler systems or on fires involving Class B flammable or combustible liquids.

1.1.4 See Annex B for publications that address tactical use of Class A foam.

1.1.5 This document is not intended to discourage the use of emerging technologies and practices, provided that the recommended level of safety is not lessened.

1.2 Purpose. The purpose of this document is to present information on the safe and effective use of Class A foam for fire fighting and protection.

1.3 Foreword. Fire-fighting foam is a mass of air-filled bubbles formed by mixing air with a surfactant solution. Surfactant solutions are prepared by proportioning a foam concentrate with water. Fire-fighting foams have been designed for use on different fuel types. There are two broad categories of fire-fighting foam — Class A and Class B. Class B foams are designed for use on fires involving flammable and combustible liquids and are discussed in NFPA 11. Class A foams are best suited for use on fires involving ordinary combustibles (Class A fuels) and are not recommended for use on Class B fuels unless tested and listed for this purpose. Class A foams have a variety of expansion ratios. Low-expansion Class A foams are most often used in the applications discussed in this guide. Class A foam concentrates, when mixed with water at concentrations in the range of 0.1 to 1.0 percent by volume, produce an array of foam solutions and foams. Class A foam used in fire fighting is discussed in this guide.

1.3.1 Although shown to be effective as early as the 1930s, fire-fighting foam was not used on Class A fuels until the mid 1980s. By that time, improvements in foam concentrate and application systems had progressed to the point where their use was practical and growing. Since that time, a number of effective Class A foam concentrates and an array of foam generation and application hardware have been developed and optimized. For more information on Class A foam and foam proportioning equipment, see NFPA 1150 and NFPA 1901. Fire apparatus using foam proportioners, aerating nozzles, and compressed air foam systems (CAFS) can use Class A foam concentrates to produce foam. Foam can also be applied aurally from water-scooping fixed- and rotary-wing aircraft. The resulting foams are effective on fires in the variety of fuels found in structure fires, wildland fires, and the rural/urban interface.

1.3.2 Class A foams can be characterized by expansion ratio, drain time, and appearance. It is important to be able to identify the type of foam being produced based on the foam’s appearance and to understand which type of foam is needed for a given fire situation. Wet and fluid foams contain more water per unit volume than drier foams and are more effective in fire extinguishment. Drier foams containing less water per unit volume can be used for exposure protection due to their longer drain times and adhesion to vertical surfaces. Class A foams can have different fire extinguishment and exposure protection capabilities, depending on their expansion ratio and drain time. Thus, the type and geometric arrangement of the fuel involved will determine which is the most effective type of foam.

1.3.3 The effectiveness of Class A foam depends primarily on the amount of water that it brings into contact with the fuel/fire interface for insulating, cooling, or both. Aqueous solutions that contain low concentrations of the foam additive exhibit surface tensions less than half that of water alone. This reduction improves the penetrating capability of the solution, allowing a greater amount of the applied liquid to be captured

and sorbed by porous fuels. As increasing amounts of air are introduced into the foam solution, the foam consistency changes from a wet foam to a fluid one, to a stiff, lather-like foam, and, finally, to a drier, high-expansion foam.

1.3.4 The fire fighter should be aware that by changing the characteristics of the foam, the rate of drained solution available to wet the fuel will change. Fast-draining foams provide more solution to the fuel in a shorter time frame than do slow-draining foams. The fire fighter has the ability to change the characteristics of the foam to meet different situations. This change of characteristics can be accomplished by changing the mix ratio, the type or operating pressure of the foam hardware, or the application technique.

1.3.5 Mix ratio affects physical properties such as surface tension and the wetting ability of the foam solution. Mix ratios in the range of 0.1 to 1.0 percent reduce surface tension values below that exhibited by water, resulting in improved coverage by the applied foam and wetting of the fuel.

1.3.6 Mix ratio also affects the characteristics of the foam produced with a given foam-generating system. The foam expansion and the drain time control how fast the foam solution is released to the fuel. Foam-generating systems that increase the amount of air captured within the foam solution result in greater expansion and slower drain times. Higher mix ratios increase the ease of obtaining more highly expanded foams with slower drain times, which decreases the rate of wetting and penetration.

Chapter 2 Referenced Publications

2.1 General. The documents or portions thereof listed in this chapter are referenced with in this guide and should be considered part of the recommendations of this document.

2.2 NFPA Publications. National Fire Protection Association, 1 Batterymarch Park, Quincy, MA 02169-7471.

NFPA 11, *Standard for Low-, Medium-, and High-Expansion Foam*, 2016 edition.

NFPA 1150, *Standard on Foam Chemicals for Fires in Class A Fuels*, 2010 edition.

NFPA 1901, *Standard for Automotive Fire Apparatus*, 2016 edition.

2.3 Other Publications.

Merriam-Webster's Collegiate Dictionary, 11th edition, Merriam-Webster, Inc., Springfield, MA, 2003.

2.4 References for Extracts in Advisory Sections.

NFPA 1150, *Standard on Foam Chemicals for Fires in Class A Fuels*, 2010 edition.

NFPA 1901, *Standard for Automotive Fire Apparatus*, 2016 edition.

Chapter 3 Definitions

3.1 General. The definitions contained in this chapter apply to the terms used in this guide. Where terms are not defined in this chapter or within another chapter, they should be defined using their ordinarily accepted meanings within the context in which they are used. *Merriam-Webster's Collegiate Dictionary*, 11th edition, is the source for the ordinarily accepted meaning.

3.2 NFPA Official Definitions.

3.2.1* Authority Having Jurisdiction (AHJ). An organization, office, or individual responsible for enforcing the requirements of a code or standard, or for approving equipment, materials, an installation, or a procedure.

3.2.2 Guide. A document that is advisory or informative in nature and that contains only nonmandatory provisions. A guide may contain mandatory statements such as when a guide can be used, but the document as a whole is not suitable for adoption into law.

3.2.3* Listed. Equipment, materials, or services included in a list published by an organization that is acceptable to the authority having jurisdiction and concerned with evaluation of products or services, that maintains periodic inspection of production of listed equipment or materials or periodic evaluation of services, and whose listing states that either the equipment, material, or service meets appropriate designated standards or has been tested and found suitable for a specified purpose.

3.3 General Definitions.

3.3.1 Aspirate. To draw in air; nozzle-aspirating systems draw air into the nozzle to mix with the foam solution.

3.3.2 Batch Mix. The manual addition of foam concentrate to a water storage container or tank to make foam solution.

3.3.3 Bubble. The building block of foam composed of a film of fluid enclosing a volume of air.

3.3.4* Class A Foam. Foam for use on fires in Class A fuels. [1150, 2010]

3.3.5 Class A Fuel. Materials such as vegetation, wood, cloth, paper, rubber, and some plastics in which combustion can occur at or below the surface of the material. [1150, 2010]

3.3.6* Compressed Air Foam System (CAFS). A foam system that combines air under pressure with foam solution to create foam in the hose or a mixing chamber.

3.3.7* Consistency. The cohesiveness and visual appearance of a foam, described in terms of bubble size and uniformity, bubble stability or life, and relative fluidity.

3.3.8 Direct Attack. Fire-fighting operations involving the application of extinguishing agents directly onto the burning fuel.

3.3.9 Drain Time. The time that it takes for a specified percent (25 percent) of the total solution that is contained in the foam to revert to liquid and drain out of the bubble structure. [1150, 2010]

3.3.10 Eductor. A device that uses the Venturi principle to siphon a liquid into a water stream. The pressure at the throat is below atmospheric pressure, allowing liquid at atmospheric pressure to flow into the water stream.

3.3.11* Expansion Ratio. The ratio of the volume of the foam in its aerated state to the original volume of nonaerated foam solution. [1901, 2016]

3.3.12 Exposure Protection. Application of an agent to uninjured areas to limit absorption of heat to a level that will minimize damage and/or resist ignition.

3.3.13 Fire Situation. Factors pertaining to a fire that affect decisions relating to fire suppression including but not limited to fuel types and geometry, fire characteristics and behavior, life safety hazard, type of structure, exposure, and weather.

3.3.14 Foam. The aerated solution created by forcing or entraining air into a foam solution by means of suitably designed equipment or by cascading it through the air at a high velocity.

3.3.15 Foam Blanket. A covering of foam over a surface to insulate, prevent ignition, or extinguish the fire.

3.3.16 Foam Concentrate. The foaming agent as received from the supplier that, when mixed with water, becomes foam solution.

3.3.17 Foam Proportioning System. The hardware and techniques used to mix concentrate with water to make foam solution.

3.3.18 Foam Solution. A homogeneous mixture of foam concentrate and water, in the mix ratio required for the application.

3.3.19 Foam System. A collection of equipment that, by various means, combines water and a controlled amount of foam concentrate into a foam solution and then aerates that solution.

3.3.20 High-Energy Foam System. A device or system that adds the energy of a pressurized air source to the energy of a pressurized water source to create foam.

3.3.21 Indirect Attack. Fire-fighting operations involving the application of extinguishing agents to reduce the buildup of heat released from a fire without applying the agent directly onto the burning fuel.

3.3.22 Low-Energy Foam System. A device or system that uses only energy produced by the velocity of the water stream to create foam.

3.3.23 Mix Ratio. The proportion of foam concentrate in the foam solution expressed as a volume percentage. [1150, 2010]

3.3.24 Mixing Chamber. A container used to mix foam solution and air.

3.3.25 Mop-up. See 3.3.26, Overhaul.

3.3.26 Overhaul. The final stages of fire extinguishment, following knockdown of the main body of fire, during which pockets of fire are sought out to complete extinguishment.

3.3.27 scfm (standard cubic feet per minute). An expression of airflow rate in which the airflow rate is corrected to standard temperature and pressure.

3.3.28 Scrubbing. A process of agitating foam solution and air in a confined space such as a hose, pipe, or mixing chamber to produce bubbles.

3.3.29 Slug Flow. The discharge of distinct pockets of air and water or weak foam solution due to the insufficient or uneven mixing of foam concentrate, water, and air in a compressed air foam system (CAFS). (See 7.2.8.1.)

3.3.30 Surface Tension. The elastic-like force at the surface of a liquid, which tends to minimize the surface area, causing drops to form. [1150, 2010]

3.3.31 Wetting Ability. The ability of foam solution to penetrate and soak into a solid. [1150, 2010]

Chapter 4 Properties and Characteristics of Foam Concentrate, Foam Solution, and Finished Foam

4.1 Foam Concentrate.

4.1.1 Acceptability. Only Class A foam concentrates that meet the requirements of NFPA 1150, as demonstrated by the results of testing conducted by qualified independent laboratories, are acceptable for use in fire fighting.

4.1.2 Handling.

4.1.2.1 Storage.

4.1.2.1.1* Class A foam concentrates intended for immediate use in fire-fighting operations should be stored above 40°F (4°C). Concentrate not intended for immediate use can be stored in sealed containers for at least 1 year at ambient outdoor temperatures with no significant impact on performance. Storage for periods longer than 1 year would not be expected to affect performance, but visual inspection and testing according to 4.1.4 should be conducted on an annual basis to confirm acceptability.

4.1.2.1.2 Class A foam concentrate should be stored in the containers in which it is received from the manufacturer. Alternative containers should be fabricated in accordance with the manufacturer's recommendations. Foam concentrates should be stored in closed containers at all times since they can contain solvents that are susceptible to evaporation.

4.1.2.2 Personal Protection.

4.1.2.2.1 The user should obtain a current material safety data sheet (SDS) for the Class A foam concentrate being used and keep the sheet available.

4.1.2.2.2 All personnel involved in handling, mixing, and applying foam concentrate and foam solutions should be trained in the recommended procedures that address occupational safety and health and environmental impact. All personnel should follow the manufacturer's recommendations on the product label and the SDS.

4.1.2.2.3 Contact with concentrate should be avoided due to its tendency to irritate skin and eyes. Thorough washing of the affected area is recommended as soon as possible after contact with concentrate. Clothing that is wetted with concentrate should be changed and washed before reuse. As a minimum, personnel who handle foam concentrate should wear impermeable gloves and eye protection. Skin or eyes that come in contact with concentrate should be rinsed and washed as soon as possible. Large amounts of potable or clear water should be available on site for such purposes. Personnel should avoid ingesting concentrate. Individuals who have ingested concentrate should be examined by a doctor as soon as possible.

4.1.2.2.4 Users of Class A foam products should ensure that the following conditions are met:

- (1) An SDS for the foam product should be available at a location in the workplace that allows examination by the workers prior to using that product.
- (2) Foam concentrate should not be used at a workplace unless a product label and an SDS are provided and worker instruction and training have been completed.

- (3) Labels and SDS should be available in English and other languages as prescribed by the authority having jurisdiction.
- (4) Every container in the workplace that contains foam concentrate should be labeled and should remain labeled in the prescribed manner.
- (5) Prescribed safe-handling equipment should be provided, should be in proper repair, and should be used at the workplace.

4.1.2.3 Environmental Protection.

4.1.2.3.1 The user should consult and follow the current SDS for the Class A foam concentrate.

4.1.2.3.2 Class A foam concentrates consist of biodegradable surfactants. However, significant quantities of unrecovered foam concentrate can affect the ecosystem and municipal water treatment operations.

4.1.2.3.3 When filling concentrate reservoirs, proper methods and equipment should be used to avoid water source contamination, since most foam concentrates are toxic to fish. Tanks should not leak, and operators should avoid overflow spills and discharge hose spills. All operations involving the handling of foam concentrate should be located so that concentrate does not come closer than 100 ft (30 m) to bodies of water and should be contained. Check valves should be provided to isolate and prevent backflow to water supplies.

4.1.2.3.4 Foam concentrate spills should be contained or absorbed, or both, and disposed of as required by the authority having jurisdiction (AHJ).

4.1.3 Compatibility.

4.1.3.1 Class A foam concentrates should not be mixed with Class B foam concentrates

4.1.3.2 Different brands of Class A foam concentrates might be incompatible and should not be mixed. When changing from one brand to another, the operator should flush the system with water to remove residual concentrate.

4.1.4* Inspection. Class A foam concentrate should be inspected for nonhomogeneity and the presence of crystals prior to use. In addition, the foaming properties of foam concentrate should be tested on an annual basis as described in A.4.1.4. If the concentrate contains crystals or is incapable of producing acceptable foam, the foam concentrate should be replaced.

4.2 Foam Solution.

4.2.1 Mix Ratio. The mix ratio of foam concentrate, as specified by NFPA 1150 is between 0.1 and 1.0 percent by volume. The mix ratio can be altered within this range, depending on the specific foam-generating hardware or system used, to create the desired foam properties, expansion ratio, and drain time, depending on the fuel and fire application.

4.2.2 Water. Water temperature and water quality have little effect on the surface tension or penetrating ability of foam solution. However, they can have an impact on foam generation and foam characteristics. (See Section 4.3.)

4.2.3 Handling. Most foam solutions are generated on demand. However, in some instances a batch or pre-mix system can be used. Storage time, contamination, and bacteria can affect foam development. Biodegradability is a desirable characteristic of foam solutions. Because of biodegradation, storage for more than a few days may result in deterioration of foam properties.

4.2.3.1 Personal Protection.

4.2.3.1.1 The user should obtain a current SDS for the Class A foam concentrate to be used. Any handling recommendations for foam solutions therein should be followed.

4.2.3.1.2 All personnel involved in handling, mixing, and applying foam solutions should be trained in the proper procedures with respect to occupational safety and health and environmental impact. All personnel should follow the manufacturer's recommendations on the product label and on the SDS. The personal protection concerns with foam solutions are the same as those with foam concentrates (see 4.1.2.2.3 and 4.1.2.2.4).

4.2.3.2 Environmental Protection. The environmental impacts of foam solutions are less severe than those of foam concentrates (see 4.1.2.3). However, foam solutions can have a detrimental impact on water quality, aquatic plants, fish, and other animals. Discharge of foam solution into natural waters or storm drains should be avoided whenever possible. Many factors are involved in determining the ultimate ecological impact of these chemicals. Environmental risk assessments are available and can be consulted for additional information. (See Annex B.)

4.2.4 Compatibility. Although Class A foam concentrates might not be compatible with each other, foam solutions prepared from different concentrate brands are rarely incompatible.

4.3 Foam.

4.3.1 Water Quality Impact. Water temperature and quality, including hardness, affect foam properties such as expansion ratio and drain time. Individual foam brands might behave differently in this regard, and their characteristics should be considered when a specific type of foam is desired. Although Class A foam solutions are prepared with freshwater, there are occasions when salt or brackish water is used. Because foam characteristics can be affected by water quality, the compatibility of specific brands with salt or brackish water should be predetermined.

4.3.2 Foam Type. Class A foams can be characterized by expansion ratio, drain time, and consistency. Class A foams can have different fire extinguishment and exposure protection capabilities, depending on their expansion ratio and drain time. Because the type of foam used in fire-fighting operations has a major impact on its effectiveness, it is important to be able to identify the type of foam being produced and to understand which type of foam is needed for a given fire situation. For simplification, low-expansion Class A foams are described as one of three types: wet, fluid, or stiff. (See Table 4.3.2.) Three factors with major impact on foam type are mix ratio, the type of foam-generating system, and the operating parameters of that system. Other factors that affect foam type include water quality and temperature as well as atmospheric conditions such as humidity, temperature, and wind.

Table 4.3.2 Typical Foam Characteristics

Characteristic	Foam Type				
	Wet Low-Expansion	Fluid Low-Expansion	Stiff Low-Expansion	Medium-Expansion*	High-Expansion*
Expansion ratio	1-5	5-10	10-20	20-200	200-1000
Consistency	Watery, sloppy	Watery shaving lather, sloppy	Stiff lather		
25% drain time (sec)	<30	30-90	90-120		
Generator	Nonaspirating, aspirating, CAFS	Aspirating, CAFS	CAFS		
Tactic	Direct or indirect attack	Direct or indirect attack	Direct or indirect attack		
Usage	Penetration, overhaul	⇔	Exposure protection, blanketing		

CAFS: compressed air foam system

*See 4.3.2.4.

4.3.2.1 Wet Foam. Wet foam can range from a foam solution that has an expansion ratio of 1:1 (no expansion) and a 25 percent drain time of 0 seconds to a watery mass of large and small bubbles that lack body. Wet foams have an expansion ratio of $\leq 5:1$ and a 25 percent drain time of ≤ 30 seconds. Wet foams can be used for direct and indirect fire attack. Wet foams are well suited for penetrating fuels, making them an ideal overhaul tool. Wet foams can be generated with all types of nozzles and systems.

4.3.2.2 Fluid Foam. Fluid foams have an appearance similar to watery shaving lather, with expansion ratios from 5:1 to 10:1, and 25 percent drain times of ≤ 90 seconds. Fluid foams can be used for direct and indirect fire attack. Fluid foams can be used to coat vertical and horizontal fuel surfaces to provide cooling for extinguishment and for short-term exposure protection. Fluid foams would be generated with aspirating nozzles or compressed air foam systems (CAFS).

4.3.2.3 Stiff Foam. Stiff foams have the appearance of shaving lather, expansion ratios greater than 10:1, and drain times greater than those of fluid foam. The structure of a stiff foam consists of uniform, small bubbles. Given the higher expansion ratios of stiff foam, the foam structure contains a large volume of air. The water contained in the foam is released. Stiff foams are suited for exposure protection and blanketing operations on vertical and inverted surfaces. Stiff foams are generated by a CAFS discharging through an open ball valve.

4.3.2.4 Medium- and High-Expansion Foam. Class A foam solutions with expansion ratios above 50:1 have not been evaluated and are to be of little operational effectiveness.

4.3.3 Personal Protection. All personnel involved in applying foams should be trained to avoid occupational safety and health hazards and to understand fire-fighting tactics using Class A foams. All personnel should follow the manufacturer's recommendations on the product label and on the SDS. Because foams can cause eye irritation and dryness of skin, personnel handling foam should wear protective clothing, including eye protection. They should avoid ingesting the foam.

4.3.4 Environmental Protection. The environmental concerns associated with foam are the same as those seen with foam solution. (See 4.2.3.2.)

Chapter 5 Hardware

5.1 General. Where Class A foam is used for fire fighting, the hardware used to produce it should comply with the applicable sections of this chapter. Class A foams can be applied with conventional fire fighting equipment. However, Class A foam concentrates and solutions have detergent-like properties and can remove lubricants from equipment such as pumps, seals, valves, and nozzles that come in contact with them. In addition, because of the properties of Class A foam solutions, equipment that is watertight when used with water can leak when used with foam solution. The manufacturer of the foam concentrate or equipment should be consulted for recommended lubricants, packing materials, or both. For detailed information on foam proportioning and generating systems, see NFPA 1901.

5.2 Proportioning. Except for batch mixing, foam proportioning systems that operate in the range of 0.1 to 1.0 percent foam solutions are available at either variable or fixed proportioning rates. It is recommended that systems that allow both variable water flow rates and mix ratios be used for proportioning Class A foam solutions. (See Table 5.2.)

5.2.1 Batch Mixing. Batch mixing refers to a method in which a calculated quantity of foam concentrate is manually added to a known quantity of water in a mixing container or tank, with mild agitation, to prepare a uniform foam solution. The concentrate should always be added to the water to minimize formation of foam in the mixing container.

5.2.1.1 Water. Water for manual batch mixing should be transferred from the source to the mix tank in such a manner that backflow is prevented. For accurate proportioning, the water tank should be filled to capacity or to a predetermined volume.

Table 5.2 Operating Characteristics of Proportioning Methods

Operating Characteristics	Manually Regulated Proportioning Methods			
	Manual Batch Mixing	Adjustable In-Line Eductor	Intake-Side Regulator	Around-the-Pump Proportioner
Unlimited hose length	X		X	X
Unlimited number of hose lines	X		X	X
Adjusted mix ratios			X	X
No moving parts	X	X	X	X
No loss in water flow or pressure	X		X	
Introduces foam concentrate into water tank	X		X	X
Potential loss of pump prime and/or cavitation	X		X	X
Potential discontinuity of foam supply	X			
Potential for inconsistent mix ratio	X	X	X	X
Potential solution degradation during storage	X			
Specific water flow and pressure requirements		X		
Limited nozzle elevation		X		
Depends on pump vacuum			X	
Operating Characteristics	Automatically Regulated Proportioning Methods			
	Balanced-Pressure Bladder Tank	Balanced-Pressure Pump	Electronically Controlled Direct Injection	Water-Powered Injection
Maintain desired mix ratio despite changes in water flow and pressure	X	X	X	X
Unlimited hose length	X	X	X	X
Unlimited number of hose lines	X	X	X	X
Adjusted mix ratios	X	X	X	X
No moving parts	X			
No loss in water flow or pressure			X	
Potential discontinuity of foam supply	X			
Requires auxiliary power		X	X	

5.2.1.2 Solution. Some mild agitation will be required to obtain a homogeneous foam solution. Minimal recirculation is generally sufficient. Violent agitation will cause excessive foam development within the mix tank and can result in, for example, overflowing, tank level gauge misreading, and loss of pump prime.

5.2.2 Manually Regulated Foam Proportioning System. A foam proportioning system that requires operator adjustment to maintain the mix ratio when there is a change of flow or pressure through the proportioner is referred to as a manually regulated foam proportioning system.

5.2.2.1 Adjustable In-Line Eductor. In an in-line eductor system, water is forced through a venturi in the eductor, creating a vacuum that allows foam concentrate to be drawn into the eductor at the mix ratio determined by the setting on a metering valve. In-line eductors are available in a configuration that allows the operator to bypass the venturi to supply plain water. When a bypass in-line eductor is used, the flow rate of the discharge nozzle can be different from the flow rate of the eductor. For other types of in-line eductors, the nozzle flow rate and the eductor flow rate must be the same. This flow rate should be taken into account when adjustable flow rate nozzles

with eductor systems are used. If incorrect mix ratios (from too rich to no concentrate at all) are to be avoided, adjustment by the operator can be required to compensate for changes in water flow. The eductor manufacturer's operational manual should be consulted for inlet pressure requirements and hose line and nozzle parameters. (See Figure 5.2.2.1.)

5.2.2.2 Intake Side Regulator. In an intake side regulator, vacuum created by the water pump draws foam concentrate directly into the pump intake. The regulator requires adjustment to compensate for changes in water flow. Refer to the manufacturer's operational recommendations for accurate use and system limitations. (See Figure 5.2.2.2.)

5.2.2.3 Around-the-Pump Proportioner. In this system, an eductor is installed between the water pump discharge and the intake. A small flow of water from the water pump discharge passes through the eductor, creating a vacuum that causes foam concentrate to be drawn into the eductor and discharged into the pump intake. The around-the-pump proportioner requires adjustment by the operator to compensate for changes in water flow and pressure. (See Figure 5.2.2.3.)

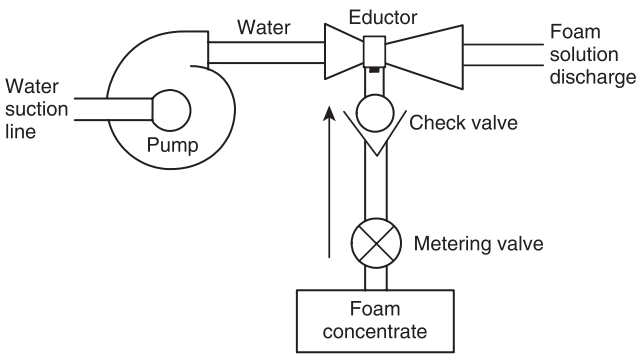

FIGURE 5.2.2.1 Adjustable In-Line Eductor. (Reprinted courtesy of National Wildfire Coordinating Group.)

5.2.3 Automatically Regulated Foam Proportioning System. An automatically regulated foam proportioning system automatically adjusts the amount of foam concentrate proportioned into the water to maintain the desired mix ratio. These automatic adjustments are made based on changes in water flow, water pressure, or solution conductivity. Some of these systems are able to proportion foam concentrate into single- or multiple-discharge outlets without adjustment.

5.2.3.1 Balanced-Pressure Bladder Tank System. The balanced-pressure bladder tank system uses a small diversion of water to pressurize a tank containing a bladder filled with foam concentrate. The concentrate is forced from the bladder and passes through a metering valve before it enters the water stream on the low-pressure side of a pressure differential valve. As differences in pressure occur due to water flow rate changes, foam concentrate flow adjusts automatically. (See Figure 5.2.3.1.)

5.2.3.2 Balanced-Pressure Pump System. The balanced-pressure pump system senses water pressure and activates a pilot-operated relief or diaphragm valve. The pressure of the pumped concentrate is automatically regulated and supplied through a venturi in the water line. (See Figure 5.2.3.2.)

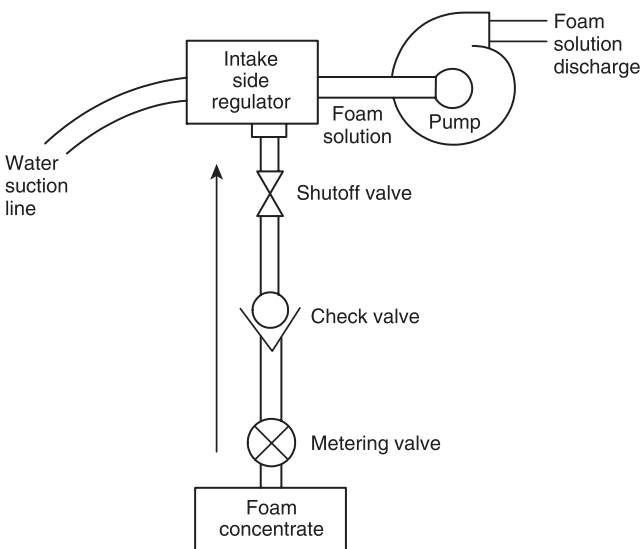

FIGURE 5.2.2.2 Intake Side Regulator. (Reprinted courtesy of National Wildfire Coordinating Group.)

5.2.3.3 Electronically Controlled Direct-Injection System. The electronically controlled proportioner adds concentrate based on measured water flow or solution conductivity. One or more in-line sensors signal a microprocessor that automatically commands a pump to deliver concentrate into the water stream at the desired mix ratio. (See Figure 5.2.3.3.)

5.2.3.4 Water-Powered Injection System. In a water-powered injection system, a water motor drives a concentrate pump. The speed of the concentrate pump is directly proportional to the water flow through the system and automatically delivers concentrate at the desired mix ratio. (See Figure 5.2.3.4.)

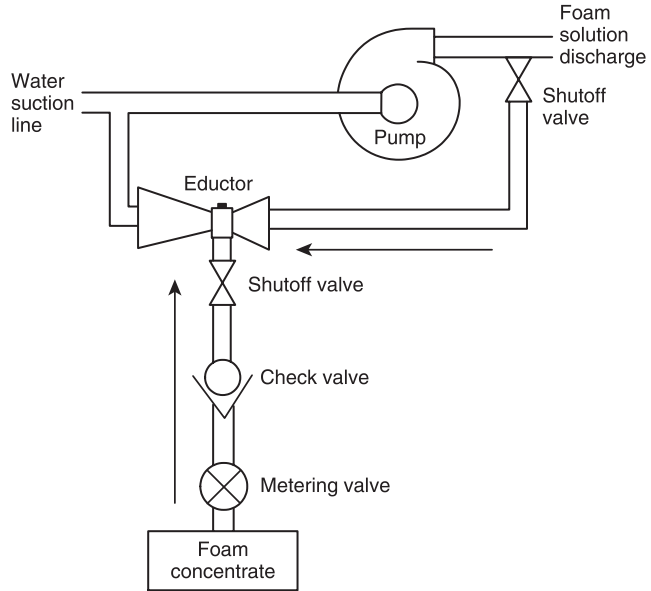

FIGURE 5.2.2.3 Around-the-Pump Proportioner. (Reprinted courtesy of National Wildfire Coordinating Group.)

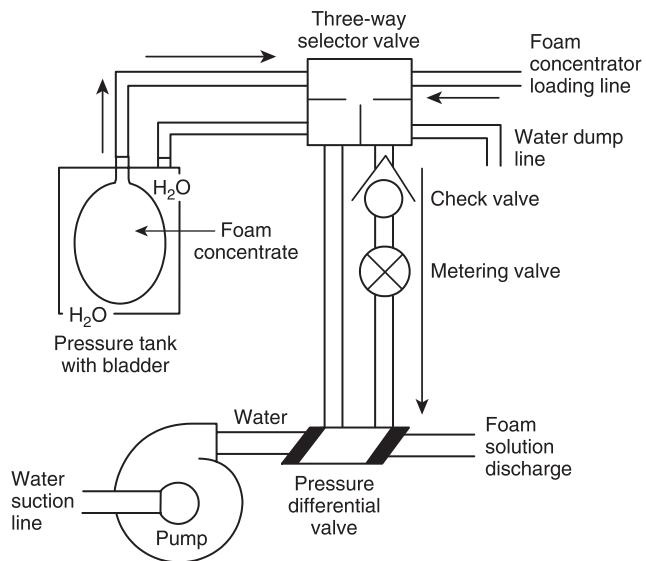

FIGURE 5.2.3.1 Balanced-Pressure Bladder Tank System. (Reprinted courtesy of National Wildfire Coordinating Group.)

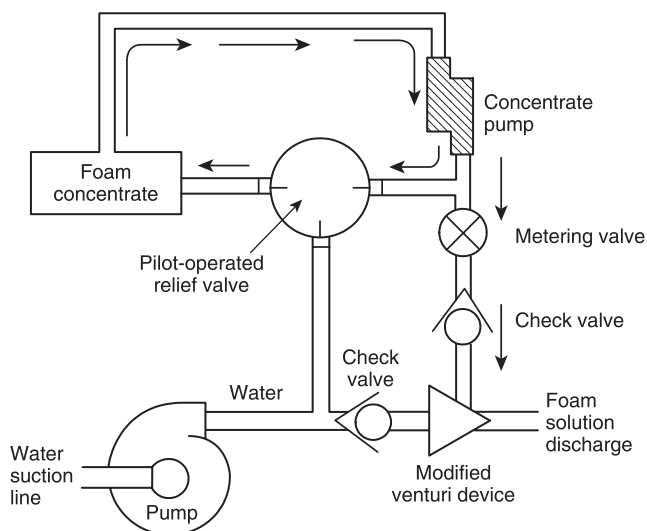

FIGURE 5.2.3.2 Balanced-Pressure Pump System. (Reprinted courtesy of National Wildfire Coordinating Group.)

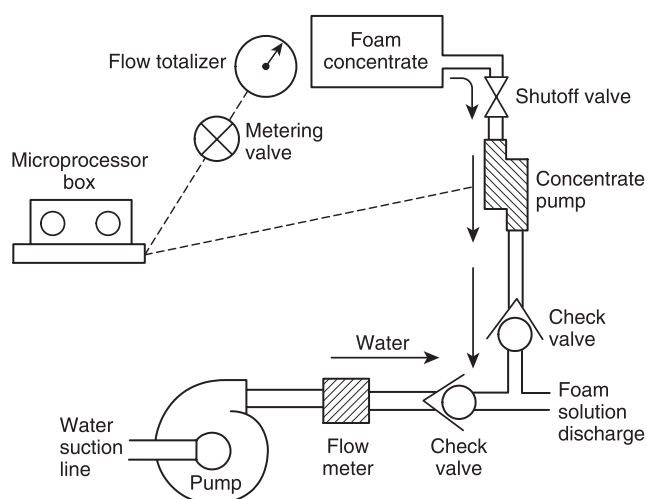

FIGURE 5.2.3.3 Electronically Controlled Direct-Injection System. (Reprinted courtesy of National Wildfire Coordinating Group.)

5.3 Foam Generation and Discharge. Class A foam can be applied with any discharge device. Discharge systems (both low- and high-energy) are discussed in 5.3.1 through 5.3.2.1.2. The user should choose the most appropriate device to meet the objective of each application.

5.3.1 Low-Energy Foam Systems. Several different low-energy foam systems are available to generate and deliver foam.

5.3.1.1 Nonaspirating-Type Nozzles. Class A foam solution can be applied with any type of nonaspirating nozzle — for example, a smooth-bore nozzle or a combination (spray and straight stream) nozzle. When using adjustable flow rate nozzles with manually regulated foam proportioning systems,

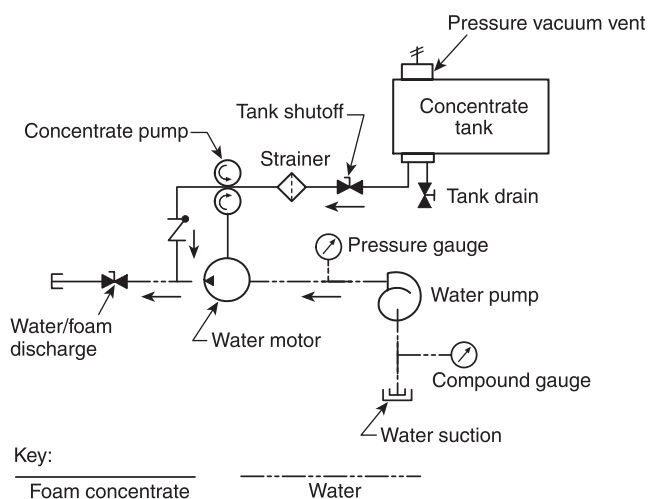

FIGURE 5.2.3.4 Water-Powered Injection System. (Reprinted courtesy of National Wildfire Coordinating Group.)

changing the nozzle flow rate can require adjustment to the proportioner to keep the foam consistency constant. If not adjusted, the foam proportioning system might be rendered inoperable. Application is made using standard water-only techniques at typical concentrations of 0.2 to 0.5 percent. These types of nozzles produce a wet foam that is used for direct and indirect attack and overhaul.

5.3.1.2 Aspirating-Type Nozzles. Aspirating nozzles entrain air into the foam solution stream. Such nozzles produce higher expansion ratios than nonaspirating nozzles. Many designs are available to users who are pursuing the desired foam expansion ratio at the greatest discharge distance. In general, nozzles designed for greater discharge distance produce low-expansion-ratio foam, while those designed for increased expansion ratios have shorter discharge distances.

5.3.1.2.1 Low-Expansion Nozzles. Low-expansion nozzles develop expansion ratios up to 20:1. However, at 0.1 to 1.0 percent mix ratios, foam with expansion ratios greater than 10:1 are rarely obtained. Low-expansion nozzles produce wet or fluid foam that is used for exposure protection, direct attack, and overhaul. Most low-expansion nozzles result in a fixed straight stream discharge that offers little to no margin of safety from radiant heat in an interior application. For this reason, a low-expansion, single-function nozzle or low-expansion attachment is not recommended for interior attack. The various types of low-expansion aspirating nozzles are illustrated in Figure 5.3.1.2.1(a) through Figure 5.3.1.2.1(e).

5.3.1.2.2 Medium-Expansion Nozzles. Although it is unlikely that expansion ratios greater than 50:1 can be achieved with Class A foam solutions, medium-expansion foam nozzles can be used with these solutions. Medium-expansion nozzles are designed to develop foam expansion ratios between 20:1 and 200:1. These nozzles have larger-diameter foam tubes than low-expansion nozzles and often employ a screen at the end of the tube. They are also limited to short discharge distances. Medium-expansion foam is useful in blanketing operations. It is most used for overhaul. Some nozzles and nozzle attachments are available that produce either low- or medium-expansion foams. See NFPA 11 for more information.

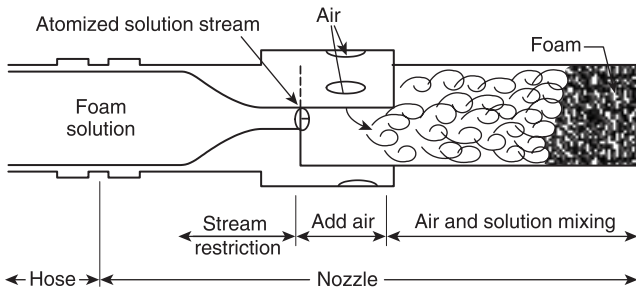

FIGURE 5.3.1.2.1(a) Single-Function Foam Device.

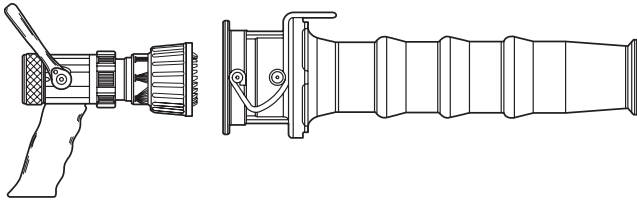

FIGURE 5.3.1.2.1(b) Combination Nozzle with Low-Expansion Foam Attachment.

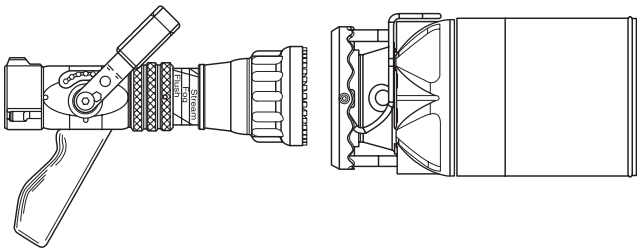

FIGURE 5.3.1.2.1(c) Combination Nozzle with Multi-Expansion Foam Attachment.

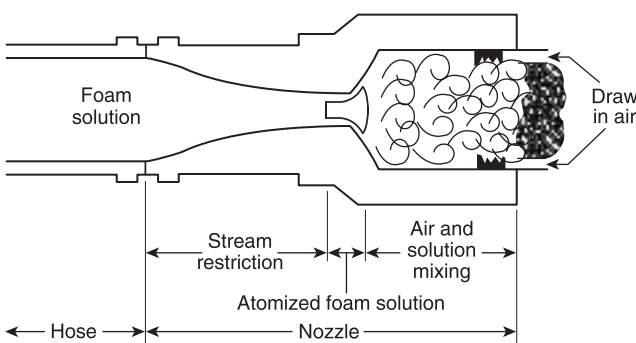

FIGURE 5.3.1.2.1(d) Multifunction Foam Device.

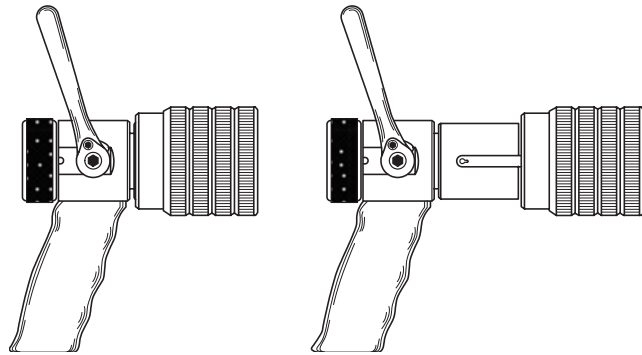

FIGURE 5.3.1.2.1(e) Combination Nozzle with Retractable Sleeve.

5.3.1.2.3 High-Expansion Generators. This equipment and associated methods are limited to fires in confined spaces. There has been very little experience in the use of high-expansion foam generators with Class A foam solutions. The discharge characteristics of the high-expansion equipment should be verified by actual tests. See NFPA 11 for more information.

5.3.2 High-Energy Foam System. The only high-energy foam system in use is the compressed air foam system (CAFS).

5.3.2.1* Compressed Air Foam System. A CAFS is a foam generation and delivery system that combines air under pressure with foam solution to create foam in the hose or mixing chamber. See 5.3.2.1.2 for the impact of hose on foam generation. A CAFS consists of a pressurized air source, a source of foam solution (water pump and proportioner), and a means to apply the foam (hose and nozzle). A CAFS allows the operator to control three elements of foam production: water, foam concentrate, and compressed air.

5.3.2.1.1 Nozzles. The choice of nozzle depends on how the foam is to be applied and the type of foam desired. Conventional and variable pattern (combination) nozzles, wands, and other attachments are compatible with CAFS. A full flow ball valve or smooth bore nozzle is used to discharge CAFS foam. The larger the discharge opening, the drier the CAFS foam. Other nozzle types, such as combination nozzles, will remove air from the foam, resulting in discharge of a wetter foam with reduced range. This capability can be used to advantage to break the bubble structure of the foam and create a foam solution for rapid penetration. Variable-pattern nozzles allow CAFS foam to be discharged in protective fog patterns.

5.3.2.1.2 Fire Hose. Hose used by the fire service for the delivery of water is appropriate for use with CAFS. Hose length and liner surface affect foam characteristics. Since most CAFS do not have a mixing chamber or other in-line mixer, they depend on friction between the foam solution and the hose liner to mix foam solution and air. Fire hose filled with CAFS foam weighs less than hose filled with foam solution or water but will kink more readily than water-filled hose. Kinking and length of hose can cause changes in foam quality and flow rate.

5.4 Check Valves. Check valves should be provided to isolate and prevent backflow of foam solution to water supplies, system supply reservoirs, and pumps.

Chapter 6 Operational Considerations

6.1 General.

6.1.1 This chapter provides guidelines on the selection of foam characteristics (*see 4.3.2*) for various fire situations, use of foam during fire fighting, and post-incident system maintenance. In most situations, fire-fighting techniques are similar for both Class A foam and water attack. However, Class A foam has greater versatility in certain situations. The proper selection of foam characteristics and application technique varies depending on resources, fire situation, material to be protected, and time available.

6.1.2 Frequent training is vital to the establishment of application proficiency and fire fighter safety. Prior to using Class A foam in a fire situation, fire fighters should develop a practical understanding of its applications and limitations.

6.2 Selection of Foam Characteristics and Application Techniques. The selection of foam characteristics (*see 4.3.2*) varies depending on the fire situation. Foam solution flow rates and hose sizes for any given fire should be the same as the accepted flow rates and hose sizes for plain water. A combination of the various foam characteristics might be of particular benefit depending on the fire situation. The mix ratio necessary to produce the desired foam characteristics varies depending on factors such as the foam concentrate selected, system design, temperature, operating parameters, and water quality. The concentrate and hardware manufacturers' instructions should be consulted for guidelines in this regard.

6.3 Operator Information.

6.3.1 Operators should be aware that foam system design and components, such as mixing chambers, plumbing and educators, can result in additional friction loss, which could affect fireground hydraulic calculations. However, since foam solutions have a lower surface tension than water, reduced overall friction loss can occur.

6.3.2 The foam-generating system should be tested and calibrated according to the manufacturer's recommendations. Additional information on testing can be found in NFPA 1901.

6.4 Routine and Post-Incident System Maintenance. Maintenance of the foam system should be performed on a routine basis and after each use in accordance with the manufacturer's recommendations.

6.4.1 The entire system should be flushed according to the manufacturer's recommendations. This flushing should be performed prior to leaving the scene or in accordance with the policies of the AHJ. Some agencies have found it convenient to perform this task during the last phase of overhaul to avoid unnecessary contamination of surrounding terrain.

6.4.2 Due to the potential for incompatibility, concentrate tanks should be cleaned according to the concentrate and/or hardware manufacturers' recommendations when a different Class A concentrate is introduced into the system. This cleaning should also be done whenever different concentrate is introduced during fire operations. Class A and B concentrates should not be mixed because of potential incompatibility or performance difficulties. If it is desired to use Class B foam concentrate in a Class A concentrate tank, or vice versa, extra care should be taken to avoid contamination of the two concentrates.

6.4.3 When operations have been completed, areas where concentrate has been handled should be examined for evidence of spillage. Any spilled concentrate and all empty containers should be collected and disposed of. (*See 4.1.2.3.4.*)

6.5 Post-Incident Documentation. The incident report should reflect the use of Class A foam including the amount of concentrate used, the mixing ratios, the brand, and the specific location of use. During cause and origin investigations, the use of Class A foam should be noted, because some components of Class A foam concentrate might mask or mimic accelerants.

Chapter 7 Operational Safety

7.1 General. Fire-fighting safety requires training prior to the incident and coordination of all emergency responders on the fire site. Foam concentrates are similar in composition to common household detergents and shampoos. However, some safety considerations should be noted because of the prolonged exposure and large volumes that are used in fire-fighting applications. Class A foam solutions used in fire fighting are at least 99 percent water. The remaining 1 percent contains surfactants and other functional components. The manufacturer's SDS should be referred to for recommendations and information about the specific foam to be used. The SDS should be available to operators of vehicles carrying Class A foam concentrate.

7.2 Working Conditions.

7.2.1 Personal Protective Equipment. When concentrates are handled, splashproof eye protection and waterproof gloves and boots (rubber or plastic) should be worn. Personal protective equipment is further discussed in 4.1.2.2, 4.2.3.1, and 4.3.3.

7.2.1.1 Due to the lower surface tension of foam solution, fire fighter turnouts and other protective clothing can become saturated with solution. Fire fighters need to be aware that the resulting increased weight of the material can cause fatigue and hamper mobility. Saturated turnouts and other protective clothing can lose some of their protective characteristics.

7.2.2 Visibility. Foam on the fireground can mask weak and damaged floors and other hazards. Vision can be obscured or obstructed by foam on vehicle windshields, face shields, SCBA masks, thermal imaging cameras, or eye protection.

7.2.3 Footing. Foam concentrates, foam solutions, and foam itself can be slippery. Caution should be exercised when moving about firegrounds on which foam or foam-related products have been used.

7.2.4 Electronic Equipment. Due to the reduced surface tension of foam solutions, watertight cases might leak, and the equipment could be damaged and cease to operate.

7.2.5 Electrical Hazards. The same electrical shock hazards exist when Class A foam is used as when water is used.

7.2.6 Nozzles. As is the case when working with water, care should be taken during the opening and closing of pressurized valves when using Class A foam.

7.2.7 Heat and Ventilation. Class A foam is more effective than water when achieving knockdown. However, flow should be continued after knockdown until sufficient temperature reduction is achieved. Temperature reduction depends on the quantity of water applied. Active and aggressive ventilation should be considered by the incident commander at every stage of fireground operations.

7.2.8 High-Energy (CAFS) Considerations. High-energy foam systems create some safety issues unique to their operation. Personnel using CAFS should receive training in proper operation of the pumping system and handling of the hose and nozzle. With the additional consideration of the foam proportioner and air compressor, the pump operator's responsibility to provide the appropriate foam to the nozzle includes more than operation of the water pump. Foam generation in the hose depends on adequate foam concentrate and air being added to the water. Accepted formulas for friction loss do not apply. Because compressed air foam is a compressible medium, water hammer does not occur in the shutting down of discharge devices.

7.2.8.1 Slug Flow. The continuity of foam production can be interrupted, resulting in slug flow for a number of reasons. Slug flow compromises effective discharge operations, nozzle control, and operator safety. To prevent slug flow, it is important to provide a continuous flow of a homogeneous mix of solution and air to create the appropriate foam type. Some of the factors that can create slug flow include interruption of foam solution supply and the inadequate mixing of air and foam solution.

7.2.8.2 Discharge Devices. The nozzle operator should understand the effect on nozzle reaction created by the compressed air in the hose. While a discharge device is closed, energy continues to build in the hose line. When the discharge device is opened, this built-up energy can create extreme nozzle reaction. The shutoff should be opened slowly, and the operator should stand with feet apart and a low center of gravity. A pistol grip ball shutoff is recommended for further stability and safety.

Annex A Explanatory Material

Annex A is not a part of the recommendations of this NFPA document but is included for informational purposes only. This annex contains explanatory material, numbered to correspond with the applicable text paragraphs.

A.3.2.1 Authority Having Jurisdiction (AHJ). The phrase “authority having jurisdiction,” or its acronym AHJ, is used in NFPA documents in a broad manner, since jurisdictions and approval agencies vary, as do their responsibilities. Where public safety is primary, the authority having jurisdiction may be a federal, state, local, or other regional department or individual such as a fire chief; fire marshal; chief of a fire prevention bureau, labor department, or health department; building official; electrical inspector; or others having statutory authority. For insurance purposes, an insurance inspection department, rating bureau, or other insurance company representative may be the authority having jurisdiction. In many circumstances, the property owner or his or her designated agent assumes the role of the authority having jurisdiction; at government installations, the commanding officer or departmental official may be the authority having jurisdiction.

A.3.2.3 Listed. The means for identifying listed equipment may vary for each organization concerned with product evaluation; some organizations do not recognize equipment as listed unless it is also labeled. The authority having jurisdiction should utilize the system employed by the listing organization to identify a listed product.

A.3.3.4 Class A Foam. The foam bubbles and the solution draining from them attach to and penetrate Class A fuels due to the reduced surface tension imparted to the water by the foam concentrate. The bubbles hold moisture and release it as the foam breaks down, prolonging the time the moisture can be absorbed by the fuels. When applied in adequate quantities, the foam acts to exclude air from the fuel-air interface, envelop combustible vapors, and resist disruption due to wind, heat, and flame.

A.3.3.6 Compressed Air Foam System (CAFS). A CAFS consists of a pressurized air source, pressurized source of foam solution, and a means to apply the foam (hose, nozzle, turret, etc.). The pressurized air source could be an air compressor or a cylinder of compressed air. The foam solution could be from a pressurized tank of foam solution or from a water pump and foam proportioning system.

A.3.3.7 Consistency. The following are examples of foam properties: watery, free flowing, pourable, deforming, and stiff. Foams exhibiting the full range of consistencies have utility in the various fire protection and suppression objectives.

A.3.3.11 Expansion Ratio. The slang term “expansion” is often used in the field to mean expansion ratio.

A.4.1.2.1.1 Class A foam concentrates become thicker (more viscous) at cold temperatures. At temperatures below about 40°F (4°C), the thicker foam concentrates can be difficult to handle, transfer and/or proportion. Although they will return to a usable condition when warmed, a quantity equivalent to one day's anticipated use should be stored at a temperature at which it can be used without difficulty. Concentrates stored below 40°F (4°C) should be warmed to 60°F (16°C) or above, if possible, prior to use. Warmed concentrate provides better performance than cold concentrate, when mixed with cold water. Some concentrates at lower temperatures will not readily mix with water. Better performance can be achieved, however, when cold concentrate is mixed at higher concentrations.

A.4.1.4 The following steps can be used to check the foam expansion ratio and drain time of a foam solution:

- (1) Prepare a 1.0 percent foam solution by placing 2 tsp (10 mL) of foam concentrate in 0.26 gal (1 L) of the typical water that is available for fire fighting and mixing the solution.
- (2) Place 2 tsp (10 mL) of the foam solution in a 6.7 Tbsp or 0.4 cup (100 mL) stoppered, graduated cylinder having 0.2 tsp (1.0 mL) graduations between the 0 and 2 tsp (0 and 10 mL) marks. If the mixing in step (1) has agitated the solution into foam, let the foam drain back into solution before taking the sample or be sure the sample consists only of foam solution.
- (3) Place the stopper in the graduated cylinder and hold it in place with the thumb, as illustrated in Figure A.4.1.4. Shake the cylinder vigorously in a 90-degree arc in the manner shown until all the liquid is incorporated in the foam structure.

- (4) Immediately after shaking, start a stopwatch and record the volume of foam and the volume of solution in the cylinder.
- (5) Record the volume of drained solution in the bottom of the cylinder at 1-minute intervals for 5 minutes and then after 10 minutes and 15 minutes, or until such time that 0.5 tsp (2.5 mL) of foam solution has drained from the foam.
- (6) Calculate the foam expansion ratio by dividing the volume of foam recorded in step (4) by 10.
- (7) Determine the 25 percent drain time by subtracting the volume of solution recorded in step (4) from the volume of drained solution recorded at each time interval in step (5) and extrapolating the data to determine the time when 0.5 tsp (2.5 mL) of solution has drained from the foam.
- (8) The test should be repeated at least three times using fresh foam solution for each test.
- (9) The average of all expansion ratio values and the average of all drain time values should be calculated and each reported.

This test method was developed to provide the user or laboratory with a means of determining the foaming performance of concentrates and solutions. The test allows the user to examine any effects of different types of water or any effects of storage time or conditions on the foaming ability of concentrates or solutions. The user should note that, in practice, foam expansion ratios are dependent on mix ratio, water quality, and the system used to generate the foam. Increasing the mix ratio can be necessary to generate the desired foam consistency where consistency is affected by poor water quality, cold water, or degradation of concentrate or solution.

A 5.3.2.1 CAFS-generated foam can be used for interior and exterior attack (both direct or indirect), exposure protection, and overhaul. Unless designed for the purpose, the use of standpipe systems or fixed aerial apparatus piping might be detrimental to the quality of the foam, the system, or both. Elevation differences between the nozzle and the pump or hose-lay length, or both, can impact the quality of the CAFS-produced foam. Radical changes in the flow direction or conduit diameter can affect foam quality. The type of foam can be controlled by varying the mix ratio of concentrate to water, the ratio of airflow to solution flow, or both. Typical CAFS mix ratios are 0.2 to 0.5 percent foam concentrate and 0.5 to 3.0 scfm/gpm (air flow/solution flow). It is important for safety and effectiveness that a CAFS be designed to provide a homogeneous mix of solution and pressurized air to create the

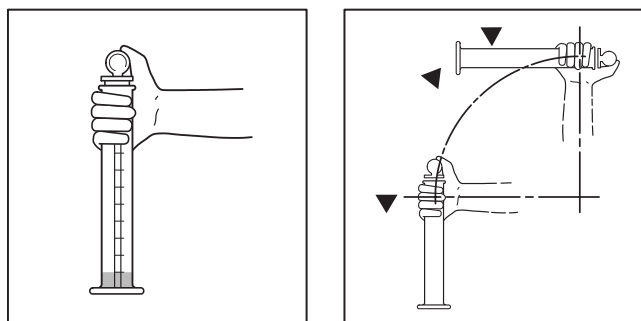

FIGURE A.4.1.4 Shaking Motion for Cylinder with Stopper in Place.

appropriate foam type for each fire-fighting situation. A CAFS has the capability of increasing the discharge distance of low-expansion foam at any given water flow rate due to the energy provided by the compressed air.

Annex B Informational References

B.1 Referenced Publications. (Reserved)

B.2 Informational References. The following documents or portions thereof are listed here as informational resources only. They are not directly referenced in this guide.

B.2.1 NFPA Publications. National Fire Protection Association, 1 Batterymarch Park, Quincy, MA 02169-7471.

NFPA 1001, *Standard for Fire Fighter Professional Qualifications*, 2013 edition.

NFPA 1051, *Standard for Wildland Fire Fighter Professional Qualifications*, 2016 edition.

B.2.2 Fire Protection Publications. Oklahoma State University, Stillwater, OK 74078.

Principles of Foam Fire Fighting, 2nd edition, 2003.

Wildland Fire Fighting for Structural Firefighters, 4th edition, 2003.

B.2.3 U.S. Government Publications. U.S. Forest Service web site (<http://www.fs.fed.us/rm/fire/>) or Program Leader, Wildland Fire Chemical Systems, U.S. Forest Service, 5785 Highway 10 West, Missoula, MT 59808-9361.

“Chemicals Used in Wildland Fire Suppression: A Risk Assessment,” Labat Anderson Incorporated for U.S. Forest Service, Intermountain Fire Sciences Laboratory, July 1996.

“Human Health Risk Assessment: Wildland Fire-Fighting Chemicals.” Labat-Anderson Incorporated for U.S. Forest Service, Missoula Technology and Development Center, January 22, 2003 (with March 6, 2003 revisions).

“Ecological Risk Assessment: Wildland Fire-Fighting Chemicals.” Labat-Anderson Incorporated for U.S. Forest Service, Missoula Technology and Development Center, 2007.

Proceedings: International Wildland Fire Foam Symposium, 1994.

B.2.4 U.S. Government Publications. National Interagency Fire Center, 3833 South Development Ave., Boise, ID 83705-5354.

Foam vs. Fire: Primer, National Wildfire Coordinating Group, NFES 2270, 1992.

Foam vs. Fire: Class A Foam for Wildland Fires, National Wildfire Coordinating Group, NFES 2246, 1993.

Foam vs. Fire: Aerial Application, National Wildfire Coordinating Group, NFES 1845, 1995.

B.2.5 U.S. Government Publications. Available from <http://fire.nist.gov/bfrlpubs/> or from the Building and Fire Research Laboratory, National Institute of Standards and Technology, 100 Bureau Drive, Stop 8600, Gaithersburg, MD 20899.

NISTIR 6191, *Demonstration of Biodegradable, Environmentally Safe, Non-Toxic Fire Suppression Liquids*, National Institute of Science and Technology, July 1998.

B.2.6 Additional Informational References.

Coletti, Dominic J., *Class A Foam — Best Practice for Structural Fire Fighters*, Lyons Publishing, Royersford, PA, 1998.

Coletti, Dominic J., and Davis, Larry, *Foam Firefighting Operations I*, Essentials of Class A Foam — Awareness Level, Lyons Publishing, Royersford, PA, 2002.

International Fire Service Training Association (IFSTA), *Principles of Foam Firefighting*, 2nd edition, IFSTA Fire Protection Publications, 930 N. Willis, Stillwater, OK 74078, www.ifsta.org, 2003.

Liebson, John, *Introduction to Class A Foams and Compressed Air Foam Systems for the Structural Fire Service*, International Society of Fire Service Instructors, Stafford, VA, Publication No. 0-929662-08-3.

B.2.7 Useful Web Sites. National Fire Protection Association: www.nfpa.org

Firewise: www.firewise.org

U.S. Forest Service: www.fs.fed.us/fire/

B.3 References for Extracts in Informational Sections. (Reserved)

Index

Copyright © 2016 National Fire Protection Association. All Rights Reserved.

The copyright in this index is separate and distinct from the copyright in the document that it indexes. The licensing provisions set forth for the document are not applicable to this index. This index may not be reproduced in whole or in part by any means without the express written permission of NFPA.

- A-**
- Administration**, Chap. 1
 - Foreword, 1.3
 - Purpose, 1.2
 - Scope, 1.1
- Aspirate**
 - Definition, 3.3.1
- Authority Having Jurisdiction (AHJ)**
 - Definition, 3.2.1, A.3.2.1
- B-**
- Batch Mix**
 - Definition, 3.3.2
- Bubble**
 - Definition, 3.3.3
- C-**
- Class A Foam**
 - Definition, 3.3.4, A.3.3.4
- Class A Fuel**
 - Definition, 3.3.5
- Compressed Air Foam System (CAFS)**
 - Definition, 3.3.6, A.3.3.6
- Consistency**
 - Definition, 3.3.7, A.3.3.7
- D-**
- Definitions**, Chap. 3
- Direct Attack**
 - Definition, 3.3.8
- Drain Time**
 - Definition, 3.3.9
- E-**
- Eductor**
 - Definition, 3.3.10
- Expansion Ratio**
 - Definition, 3.3.11, A.3.3.11
- Explanatory Material**, Annex A
- Exposure Protection**
 - Definition, 3.3.12
- F-**
- Fire Situation**
 - Definition, 3.3.13
- Foam**
 - Definition, 3.3.14
- Foam Blanket**
 - Definition, 3.3.15
- Foam Concentrate**
 - Definition, 3.3.16
- Foam Proportioning System**
 - Definition, 3.3.17
- Foam Solution**
 - Definition, 3.3.18
- Foam System**
 - Definition, 3.3.19
- G-**
- Guide**
 - Definition, 3.2.2
- H-**
- Hardware**, Chap. 5
 - Check Valves, 5.4
 - Foam Generation and Discharge, 5.3
 - High-Energy Foam System, 5.3.2
 - Compressed Air Foam System, 5.3.2.1, A.5.3.2.1
 - Fire Hose, 5.3.2.1.2
 - Nozzles, 5.3.2.1.1
 - Low-Energy Foam Systems, 5.3.1
 - Aspirating-Type Nozzles, 5.3.1.2
 - High Expansion Generators, 5.3.1.2.3
 - Low-Expansion Nozzles, 5.3.1.2.1
 - Medium-Expansion Nozzles, 5.3.1.2.2
 - Nonaspirating-Type Nozzles, 5.3.1.1
 - General, 5.1
 - Proportioning, 5.2
 - Automatically Regulated Foam Proportioning System, 5.2.3
 - Balanced-Pressure Bladder Tank System, 5.2.3.1
 - Balanced-Pressure Pump System, 5.2.3.2
 - Electronically Controlled Direct-Injection System, 5.2.3.3
 - Water-Powered Injection System, 5.2.3.4
 - Batch Mixing, 5.2.1
 - Solution, 5.2.1.2
 - Water, 5.2.1.1
 - Manually Regulated Foam Proportioning System, 5.2.2
 - Adjustable In-Line Eductor, 5.2.2.1
 - Around-the-Pump Proportioner, 5.2.2.3
 - Intake Side Regulator, 5.2.2.2
 - High-Energy Foam System**
 - Definition, 3.3.20
 - I-**
 - Indirect Attack**
 - Definition, 3.3.21
 - Informational References**, Annex B

- L-**
- Listed**
Definition, 3.3.23, A.3.2.3
- Low-Energy Foam System**
Definition, 3.3.22
- M-**
- Mix Ratio**
Definition, 3.3.23
- Mixing Chamber**
Definition, 3.3.24
- Mop-up**
Definition, 3.3.25
- O-**
- Operational Considerations, Chap. 6**
General, 6.1
Operator Information, 6.3
Post-Incident Documentation, 6.5
Routine and Post-Incident System Maintenance, 6.4
Selection of Foam Characteristics and Application Techniques, 6.2
- Operational Safety, Chap. 7**
General, 7.1
Working Conditions, 7.2
Electrical Hazards, 7.2.5
Electronic Equipment, 7.2.4
Footing, 7.2.3
Heat and Ventilation, 7.2.7
High-Energy (CAFS) Considerations, 7.2.8
Discharge Devices, 7.2.8.2
Slug Flow, 7.2.8.1
Nozzles, 7.2.6
Personal Protective Equipment, 7.2.1
Visibility, 7.2.2
- Overhaul**
Definition, 3.3.26
- P-**
- Properties and Characteristics of Foam Concentrate, Foam Solution, and Finished Foam, Chap. 4**
- Foam, 4.3
Environmental Protection, 4.3.4
Foam Type, 4.3.2
Fluid Foam, 4.3.2.2
Medium- and High-Expansion Foam, 4.3.2.4
Stiff Foam, 4.3.2.3
Wet Foam, 4.3.2.1
Personal Protection, 4.3.3
Water Quality Impact, 4.3.1
- Foam Concentrate, 4.1
Acceptability, 4.1.1
Compatibility, 4.1.3
Handling, 4.1.2
Environmental Protection, 4.1.2.3
Personal Protection, 4.1.2.2
Storage, 4.1.2.1
Inspection, 4.1.4, A.4.1.4
- Foam Solution, 4.2
Compatibility, 4.2.4
Handling, 4.2.3
Environmental Protection, 4.2.3.2
Personal Protection, 4.2.3.1
Mix Ratio, 4.2.1
Water, 4.2.2
- R-**
- Referenced Publications, Chap. 2**
- S-**
- scfm (standard cubic feet per minute)**
Definition, 3.3.27
- Scrubbing**
Definition, 3.3.28
- Slug Flow**
Definition, 3.3.29
- Surface Tension**
Definition, 3.3.30
- W-**
- Wetting Ability**
Definition, 3.3.31

Sequence of Events for the Standards Development Process

Once the current edition is published, a Standard is opened for Public Input.

Step 1 – Input Stage

- Input accepted from the public or other committees for consideration to develop the First Draft
- Technical Committee holds First Draft Meeting to revise Standard (23 weeks); Technical Committee(s) with Correlating Committee (10 weeks)
- Technical Committee ballots on First Draft (12 weeks); Technical Committee(s) with Correlating Committee (11 weeks)
- Correlating Committee First Draft Meeting (9 weeks)
- Correlating Committee ballots on First Draft (5 weeks)
- First Draft Report posted on the document information page

Step 2 – Comment Stage

- Public Comments accepted on First Draft (10 weeks) following posting of First Draft Report
- If Standard does not receive Public Comments and the Technical Committee chooses not to hold a Second Draft meeting, the Standard becomes a Consent Standard and is sent directly to the Standards Council for issuance (see Step 4) or
- Technical Committee holds Second Draft Meeting (21 weeks); Technical Committee(s) with Correlating Committee (7 weeks)
- Technical Committee ballots on Second Draft (11 weeks); Technical Committee(s) with Correlating Committee (10 weeks)
- Correlating Committee Second Draft Meeting (9 weeks)
- Correlating Committee ballots on Second Draft (8 weeks)
- Second Draft Report posted on the document information page

Step 3 – NFPA Technical Meeting

- Notice of Intent to Make a Motion (NITMAM) accepted (5 weeks) following the posting of Second Draft Report
- NITMAMs are reviewed and valid motions are certified by the Motions Committee for presentation at the NFPA Technical Meeting
- NFPA membership meets each June at the NFPA Technical Meeting to act on Standards with “Certified Amending Motions” (certified NITMAMs)
- Committee(s) vote on any successful amendments to the Technical Committee Reports made by the NFPA membership at the NFPA Technical Meeting

Step 4 – Council Appeals and Issuance of Standard

- Notification of intent to file an appeal to the Standards Council on Technical Meeting action must be filed within 20 days of the NFPA Technical Meeting
- Standards Council decides, based on all evidence, whether to issue the standard or to take other action

Notes:

1. Time periods are approximate; refer to published schedules for actual dates.
2. Annual revision cycle documents with certified amending motions take approximately 101 weeks to complete.
3. Fall revision cycle documents receiving certified amending motions take approximately 141 weeks to complete.

Committee Membership Classifications^{1,2,3,4}

The following classifications apply to Committee members and represent their principal interest in the activity of the Committee.

1. M *Manufacturer*: A representative of a maker or marketer of a product, assembly, or system, or portion thereof, that is affected by the standard.
2. U *User*: A representative of an entity that is subject to the provisions of the standard or that voluntarily uses the standard.
3. IM *Installer/Maintainer*: A representative of an entity that is in the business of installing or maintaining a product, assembly, or system affected by the standard.
4. L *Labor*: A labor representative or employee concerned with safety in the workplace.
5. RT *Applied Research/Testing Laboratory*: A representative of an independent testing laboratory or independent applied research organization that promulgates and/or enforces standards.
6. E *Enforcing Authority*: A representative of an agency or an organization that promulgates and/or enforces standards.
7. I *Insurance*: A representative of an insurance company, broker, agent, bureau, or inspection agency.
8. C *Consumer*: A person who is or represents the ultimate purchaser of a product, system, or service affected by the standard, but who is not included in (2).
9. SE *Special Expert*: A person not representing (1) through (8) and who has special expertise in the scope of the standard or portion thereof.

NOTE 1: “Standard” connotes code, standard, recommended practice, or guide.

NOTE 2: A representative includes an employee.

NOTE 3: While these classifications will be used by the Standards Council to achieve a balance for Technical Committees, the Standards Council may determine that new classifications of member or unique interests need representation in order to foster the best possible Committee deliberations on any project. In this connection, the Standards Council may make such appointments as it deems appropriate in the public interest, such as the classification of “Utilities” in the National Electrical Code Committee.

NOTE 4: Representatives of subsidiaries of any group are generally considered to have the same classification as the parent organization.

Submitting Public Input / Public Comment Through the Online Submission System

Soon after the current edition is published, a Standard is open for Public Input.

Before accessing the Online Submission System, you must first sign in at www.nfpa.org. *Note: You will be asked to sign-in or create a free online account with NFPA before using this system:*

- a. Click on Sign In at the upper right side of the page.
- b. Under the Codes and Standards heading, click on the “List of NFPA Codes & Standards,” and then select your document from the list or use one of the search features.

OR

- a. Go directly to your specific document information page by typing the convenient shortcut link of www.nfpa.org/document# (Example: NFPA 921 would be www.nfpa.org/921). Sign in at the upper right side of the page.

To begin your Public Input, select the link “The next edition of this standard is now open for Public Input” located on the About tab, Current & Prior Editions tab, and the Next Edition tab. Alternatively, the Next Edition tab includes a link to Submit Public Input online.

At this point, the NFPA Standards Development Site will open showing details for the document you have selected. This “Document Home” page site includes an explanatory introduction, information on the current document phase and closing date, a left-hand navigation panel that includes useful links, a document Table of Contents, and icons at the top you can click for Help when using the site. The Help icons and navigation panel will be visible except when you are actually in the process of creating a Public Input.

Once the First Draft Report becomes available there is a Public Comment period during which anyone may submit a Public Comment on the First Draft. Any objections or further related changes to the content of the First Draft must be submitted at the Comment stage.

To submit a Public Comment you may access the online submission system utilizing the same steps as previously explained for the submission of Public Input.

For further information on submitting public input and public comments, go to: <http://www.nfpa.org/publicinput>.

Other Resources Available on the Document Information Pages

About tab: View general document and subject-related information.

Current & Prior Editions tab: Research current and previous edition information on a Standard.

Next Edition tab: Follow the committee’s progress in the processing of a Standard in its next revision cycle.

Technical Committee tab: View current committee member rosters or apply to a committee.

Technical Questions tab: For members and Public Sector Officials/AHJs to submit questions about codes and standards to NFPA staff. Our Technical Questions Service provides a convenient way to receive timely and consistent technical assistance when you need to know more about NFPA codes and standards relevant to your work. Responses are provided by NFPA staff on an informal basis.

Products & Training tab: List of NFPA’s publications and training available for purchase.

Information on the NFPA Standards Development Process

I. Applicable Regulations. The primary rules governing the processing of NFPA standards (codes, standards, recommended practices, and guides) are the NFPA *Regulations Governing the Development of NFPA Standards (Regs)*. Other applicable rules include NFPA *Bylaws*, NFPA *Technical Meeting Convention Rules*, NFPA *Guide for the Conduct of Participants in the NFPA Standards Development Process*, and the NFPA *Regulations Governing Petitions to the Board of Directors from Decisions of the Standards Council*. Most of these rules and regulations are contained in the *NFPA Standards Directory*. For copies of the *Directory*, contact Codes and Standards Administration at NFPA Headquarters; all these documents are also available on the NFPA website at “www.nfpa.org.”

The following is general information on the NFPA process. All participants, however, should refer to the actual rules and regulations for a full understanding of this process and for the criteria that govern participation.

II. Technical Committee Report. The Technical Committee Report is defined as “the Report of the responsible Committee(s), in accordance with the Regulations, in preparation of a new or revised NFPA Standard.” The Technical Committee Report is in two parts and consists of the First Draft Report and the Second Draft Report. (See *Regs* at Section 1.4.)

III. Step 1: First Draft Report. The First Draft Report is defined as “Part one of the Technical Committee Report, which documents the Input Stage.” The First Draft Report consists of the First Draft, Public Input, Committee Input, Committee and Correlating Committee Statements, Correlating Notes, and Ballot Statements. (See *Regs* at 4.2.5.2 and Section 4.3.) Any objection to an action in the First Draft Report must be raised through the filing of an appropriate Comment for consideration in the Second Draft Report or the objection will be considered resolved. [See *Regs* at 4.3.1(b).]

IV. Step 2: Second Draft Report. The Second Draft Report is defined as “Part two of the Technical Committee Report, which documents the Comment Stage.” The Second Draft Report consists of the Second Draft, Public Comments with corresponding Committee Actions and Committee Statements, Correlating Notes and their respective Committee Statements, Committee Comments, Correlating Revisions, and Ballot Statements. (See *Regs* at 4.2.5.2 and Section 4.4.) The First Draft Report and the Second Draft Report together constitute the Technical Committee Report. Any outstanding objection following the Second Draft Report must be raised through an appropriate Amending Motion at the NFPA Technical Meeting or the objection will be considered resolved. [See *Regs* at 4.4.1(b).]

V. Step 3a: Action at NFPA Technical Meeting. Following the publication of the Second Draft Report, there is a period during which those wishing to make proper Amending Motions on the Technical Committee Reports must signal their intention by submitting a Notice of Intent to Make a Motion (NITMAM). (See *Regs* at 4.5.2.) Standards that receive notice of proper Amending Motions (Certified Amending Motions) will be presented for action at the annual June NFPA Technical Meeting. At the meeting, the NFPA membership can consider and act on these Certified Amending Motions as well as Follow-up Amending Motions, that is, motions that become necessary as a result of a previous successful Amending Motion (See 4.5.3.2 through 4.5.3.6 and Table 1 Columns 1-3 of *Regs* for a summary of the available Amending Motions and who may make them.) Any outstanding objection following action at an NFPA Technical Meeting (and any further Technical Committee consideration following successful Amending Motions, see *Regs* at 4.5.3.7 through 4.6.5.3) must be raised through an appeal to the Standards Council or it will be considered to be resolved.

VI. Step 3b: Documents Forwarded Directly to the Council. Where no NITMAM is received and certified in accordance with the Technical Meeting Convention Rules, the standard is forwarded directly to the Standards Council for action on issuance. Objections are deemed to be resolved for these documents. (See *Regs* at 4.5.2.5.)

VII. Step 4a: Council Appeals. Anyone can appeal to the Standards Council concerning procedural or substantive matters related to the development, content, or issuance of any document of the NFPA or on matters within the purview of the authority of the Council, as established by the Bylaws and as determined by the Board of Directors. Such appeals must be in written form and filed with the Secretary of the Standards Council (see *Regs* at Section 1.6). Time constraints for filing an appeal must be in accordance with 1.6.2 of the *Regs*. Objections are deemed to be resolved if not pursued at this level.

VIII. Step 4b: Document Issuance. The Standards Council is the issuer of all documents (see Article 8 of *Bylaws*). The Council acts on the issuance of a document presented for action at an NFPA Technical Meeting within 75 days from the date of the recommendation from the NFPA Technical Meeting, unless this period is extended by the Council (see *Regs* at 4.7.2). For documents forwarded directly to the Standards Council, the Council acts on the issuance of the document at its next scheduled meeting, or at such other meeting as the Council may determine (see *Regs* at 4.5.2.5 and 4.7.4).

IX. Petitions to the Board of Directors. The Standards Council has been delegated the responsibility for the administration of the codes and standards development process and the issuance of documents. However, where extraordinary circumstances requiring the intervention of the Board of Directors exist, the Board of Directors may take any action necessary to fulfill its obligations to preserve the integrity of the codes and standards development process and to protect the interests of the NFPA. The rules for petitioning the Board of Directors can be found in the *Regulations Governing Petitions to the Board of Directors from Decisions of the Standards Council* and in Section 1.7 of the *Regs*.

X. For More Information. The program for the NFPA Technical Meeting (as well as the NFPA website as information becomes available) should be consulted for the date on which each report scheduled for consideration at the meeting will be presented. To view the First Draft Report and Second Draft Report as well as information on NFPA rules and for up-to-date information on schedules and deadlines for processing NFPA documents, check the NFPA website (www.nfpa.org/docinfo) or contact NFPA Codes & Standards Administration at (617) 984-7246.



Xchange™

An online community that connects you with peers worldwide and directly with NFPA staff

Have a question about the code or standard you're reading now? NFPA Xchange™ can help!

NFPA Xchange™ is our free online community, and we want to invite you to join us there! NFPA Xchange lets you connect with professionals worldwide, explore content, share ideas, and ask questions, as the latest way to stay up-to-date on codes- and standards-related information. Plus you can:

- **ASK your peers**
- **SEARCH questions & answers**
- **READ NFPA blogs**

NFPA Members also enjoy exclusive access to the 'Members Only' section on NFPA Xchange, where you can submit technical standards questions* directly to NFPA staff or search questions that have already been submitted by others!

Join NFPA Xchange TODAY – IT'S FREE AND EASY!



Search. Share. Xchange Ideas. Get Involved Today!

*For the full terms of use, please visit nfpa.org/standard_items/terms-of-use#xchange. NFPA® is a registered trademark of the National Fire Protection Association, Quincy, MA 02169.



ویدیو - انیمیشن های اطفاء، اعلام حریق، تهویه و تخلیه دود (رایگان)

برای مشاهده هر یک از ویدیوهای زیر کافیست بر روی عنوان آن آموزش کلیک نمایید تا به صفحه ویدیو و آموزش آن عنوان هدایت شوید.

انیمیشن ویدیو

• اطفاء حریق آبی

- [سیستم اطفاء لوله خشک اسپرینکلر](#)
- [سیستم اطفاء لوله تر اسپرینکلر](#)
- [سیستم اطفاء پیش عملگر](#)
- [سیستم اطفاء واترمیست](#)
- [سیستم اطفاء سیلابی](#)

• [سیستم اطفاء فوم](#)

• [تجهیزات اطفاء حریق - تجهیزات هشدار دهنده](#)

• [تجهیزات اطفاء حریق - اسپرینکلر](#)

• [سیستم اطفاء آشپزخانه صنعتی](#)

• [سیستم اطفاء آبروسل](#)

• [سیستم اطفاء دستی](#)

• [سیستم اطفاء گازی](#)

○ [سیستم اطفاء FM200 , NOVEC, Inert Gas \(IG\)](#)

○ [سیستم اطفاء CO₂](#)

• [سیستم تهویه و تخلیه دود](#)

• [سیستم اعلام حریق](#)

○ [آدرس پذیر](#)

○ [متعارف](#)



آموزش استاندارد

- [آموزش استاندارد NFPA 13](#)
- [آموزش استاندارد NFPA 14](#)
- [آموزش استاندارد NFPA 20](#)

آموزش نرم افزار

- [اتواسپرینک](#)
- [پایروسیم](#)
- [پت فایندر](#)

دانلود استاندارد

- [ترجمه استاندارد NFPA 30,14,13,10](#)
- [تمامی استانداردهای NFPA & FM](#)
- [ترجمه استاندارد NFPA 1037](#)

محصولات

- [اتواسپرینک ۲۰۱۳ و ۲۰۱۹ به زبان فارسی برای اولین بار در ایران](#)
- [آلارم کد ۲۰۱۹ به زبان فارسی برای اولین بار در ایران](#)
- [اطفا حریق آبی](#)
- [پایپنت \(ماژول اسپرینکلر\)](#)
- [کانتم](#)
- [اعلان حریق](#)

دوره‌های حضوری

- آموزش اتواسپرینک
- آموزش آلارم کد
- آموزش پایروسیم
- آموزش کانتم + اگزاست
- آموزش اطفا آبی + پمپ + بازدید از کارگاه
- آموزش اطفا گازی
- آموزش اطفا فوم
- آموزش مبحث سوم مقررات ملی
- آموزش اعلام حریق F&G
- آموزش اعلام حریق آدرس پذیر
- آموزش اعلام حریق متعارف
- دوره آمادگی آزمون آتش نشانی (برق، مکانیک، عمران، معماری)





EDUFIRE.IR

دوره های آموزشی

ارائه تخفیف جهت خرید نرم افزارها

ارائه کد تخفیف جهت شرکت در دوره های آموزشی

طراحی تهویه
و تخلیه دود همراه با
آموزش نرم افزار
Contam

کد آموزشی ۱۰۴

۱۶ ساعت

میانی و شناخت پمپ
بوسترپمپ های آبرسانی
و آتش نشانی به همراه
بازدید از خط تولید

کد آموزشی ۱۰۳

۱۶ ساعت

طراحی اعلام حریق
Addressable
Conventional

کد آموزشی ۱۰۲

۱۶ ساعت

طراحی اطفاء حریق
آبی با نرم افزار
AutoSPRINKY۰۱۹

کد آموزشی ۱۰۱

۱۶ ساعت

طراحی اطفاء حریق
گازی
FM200 & NOVEC
CO₂

کد آموزشی ۱۰۸

۱۶ ساعت

طراحی اطفاء حریق
و آشنایی با ضوابط
سازمان آتش نشانی

کد آموزشی ۱۰۷

۱۶ ساعت

طراحی اطفاء حریق
فوم

کد آموزشی ۱۰۶

۱۶ ساعت

طراحی سیستم اعلان
آدرس پذیر همراه با
آموزش نرم افزار
AlarmCAD

کد آموزشی ۱۰۵

۱۶ ساعت

طراحی استخر، سونا
و جکوزی

کد آموزشی ۱۱۲

۱۶ ساعت

آمادگی آزمون
آتش نشانی
مکانیک - برق
عمران - معماری

کد آموزشی ۱۱۱

۱۶ ساعت

طراحی با نرم افزار
Pyrosim

کد آموزشی ۱۱۰

۱۶ ساعت

آموزش مبحث سوم
مقررات ملی ساختمان

کد آموزشی ۱۰۹

۳۲ ساعت



آموزشگاه ادوفایر
EDUFIRE

All **NFPA & FM** STANDARDS

 **EDUFIRE_NFPA**

 **EDUFIRE.IR**

 **Latest Version**

FREE

  
EDUFIRE.IR

