

FirePro Xtinguish

Condensed Aerosol Fire Extinguishing System Installation and Operation Manual



Hochiki America Corporation
7051 Village Drive, Suite 100
Buena Park, CA 90621-2268
714.522.2246 Corporate Headquarters
800.845.6692 Technical Support
<http://www.hochiki.com>

Version 1.05 - UL
Created: 09/05/2012
Revised: 11/17/2016

PN# 1700-11990

Read this installation and operation manual carefully before installing the condensed aerosol generators!!

1	Introduction	6
2	Administration	7
	2.1 Scope	7
	2.2 Purpose	7
	2.3 Trademark and Patent.....	7
	2.4 Units and Formulas	7
	2.5 Referenced Publications	7
	2.6 Definitions.....	7
3	Environmental Summary	8
	3.1 Significant New Alternatives Policy (SNAP List)	8
	3.2 Condensed Aerosol Environmental Parameters	9
4	Safety Summary	10
	4.1 General.....	10
	4.1.1 Health Effects	10
	4.2 Hazards to Personnel.....	10
	4.2.1 Potential Hazards	10
	4.2.2 Pre-Discharge Alarms and Time Delay	11
	4.2.3 Egress.....	11
	4.2.4 Reduced Visibility	11
	4.2.5 Toxicity.....	11
	4.2.6 Thermal Hazards	11
5	Condensed Aerosol Fire Extinguishing Action	12
	5.1 <i>FirePro</i> [®] Condensed Aerosol Fire Extinguishing Reaction Sequence	13
	5.2 Particle Distribution in the Aerosol Phase	14
6	<i>FirePro</i> [®] <i>Xtinguish</i> Condensed Aerosol Fire Use and Limitations	15
	6.1 Systems.....	15
	6.2 Use and Application	15
	6.3 Environmental Factors	16
	6.4 Compatibility with Other Agents	16
7	Condensed Aerosol Generator Description.....	17
	7.1 General Description of the Aerosol Generator Units.....	17
	7.1.1 The Solid Aerosol-Forming Compound FPC:.....	17
	7.1.2 The Ignition Device (Initiator):.....	17
	7.1.3 The Cooling Mechanism:.....	17
	7.1.4 The Housing (External Steel Casing):	18
	7.1.5 The Mounting Brackets:.....	18
	7.1.6 The End Plate Discharge Outlets:	18
	7.1.7 The Seal	18
	7.2 Aerosol Generator Components.....	19
8	Total Flooding Systems Design.....	21

8.1 Working Documents	21
8.1.1 Specifications.....	21
8.1.2 Working Plans.....	21
8.1.3 Approval of Plans	22
8.2 Enclosure.....	22
8.2.1 Loss of Agent.....	22
8.3 Condensed Aerosol System Agent Supply	23
8.3.1 Quantity	23
8.4 Design Application Density.....	23
8.4.1 Determining Design Application Density	23
8.4.2 Fuel Types:	23
8.5 Total Flooding Quantity	25
8.5.1 Quantity Calculation	25
8.5.2 Additional Design Factors.....	25
8.5.3 Duration of Protection.....	25
8.5.4 Discharge Time.....	25
8.5.5 Extended Discharge	25
8.5.6 Safety Vents	25
8.5.7 Generator Choice and Location.....	26
8.6 Preparing the Enclosure Prior to Aerosol Discharge.....	26
8.7 Working in a Room or Enclosure Protected by FirePro Xtinguish	26
9 Condensed Aerosol Fire Extinguishing System Arrangement	27
9.1 Minimum Safe Distances.....	27
9.2 Safety Requirements	27
9.3 Electrical Clearances.....	28
9.4 Precautions While Handling the Generator Units.....	28
9.5 Storage and Transport	29
9.6 Storage Conditions	29
9.7 Replacement / Removal from Service.....	29
10 Detection, Actuation, Alarm and Control Systems	30
10.1 General.....	30
10.2 Raceways	30
10.3 Automatic Detection	30
10.4 Operating Devices	30
10.5 Fire Alarm Control Panel	31
10.6 Operating Alarms and Indicators.....	31
10.7 Warning Devices	31
10.8 Abort Switches.....	32
10.9 Alarms Indicating Failure of Supervised Devices and Equipment	32
10.10 Warning and Instruction Signs	32

10.11	Pre-Discharge Alarms and Time Delays	32
10.12	Unwanted System Operation	32
11	Total Flooding System – Installation Examples	33
11.1	General.....	37
11.2	<i>FirePro</i> ® Condensed Aerosol Generator Installation Procedure	38
11.2.1	FNX-20 Installation Details	38
11.2.2	FNX-40 / FNX-80 / FNX-100S / FNX-200S Installation Details.....	39
11.2.3	FNX-500S Installation Details.....	39
11.3	Wiring Connections to the FirePro Xtinguish Aerosol Generators	40
11.4	Condensed Aerosol Generator Height Limitations.....	46
11.5	Condensed Aerosol Generator Initiation (Activation).....	46
11.5.1	Automatic Activation by means of a Fire Detection System.....	46
12	Hochiki HCVR-3 Releasing Fire Alarm Control Panel	48
12.1	System Components	48
12.2	System Layout.....	50
12.3	HCVR-3 Connection Overview.....	51
12.3.1	Detection Zones and Notification Appliances.....	51
12.3.2	HCVR-SQA Sequential Activator.....	51
12.3.3	Disconnect Switch (Hochiki America model HCVR-DS or SOM-R-DS).....	55
12.4	eLAN RS-H Analog/Addressable Releasing Control Panel	56
13	Total Flooding System Commissioning.....	57
13.1	General.....	57
13.2	Installation Acceptance	57
13.2.1	Basic Checks	57
13.2.2	Review Enclosure Integrity	57
13.2.3	Review Electrical Components.....	57
13.2.4	Functional Testing	59
13.2.5	System Hand-Over to Client.....	60
14	Total Flooding Systems Inspection and Maintenance	61
14.1	Inspection	61
14.2	Enclosure Inspection	61
14.3	Maintenance.....	61
14.4	Penetrations	61
14.5	Condensed Aerosol Generator Inspection	61
14.6	Training.....	62
14.7	Safety	62
15	Total Flooding System Post-Discharge Intervention.....	63
15.1	Residue Removal	63
15.2	Guidelines to Clean the Residue of Condensed Aerosol.....	63
15.3	Pre-Discharge and Post-Discharge Steps	64

15.4 Additional Information on Cleaning Electronic Components64

15.5 Dismantling *FirePro*[®] Condensed Aerosol Generators.....65

15.6 Waste and Environment65

16 Appendix A – Material Safety Data Sheets (MSDS)66

17 Appendix B – FirePro Xtinguish Aerosol Generators70

18 Appendix C – FirePro Xtinguish Generator Datasheets71

19 Appendix D – FirePro Xtinguish Generator Drawings.....90

20 Appendix E – Referenced Publications.....109

21 Appendix F – Definitions110

1 Introduction

This manual is written for those who are installing a FirePro Xtinguish condensed aerosol fire extinguishing system for total flooding applications.

Hochiki America Corporation assumes no responsibility for the application of any system other than those addressed in this manual.

The technical data contained in this manual is strictly limited for information only. **Hochiki America Corporation** believes this data to be accurate, but it is published and presented without any warranty or guarantee whatsoever. Hochiki America Corporation disclaims any liability for any use that may be made of the data and information contained herein by any and all other parties.

IMPORTANT NOTICES

Warranty Disclaimer

Hochiki America Corporation makes no guarantees of any kind, either express or implied, including but not limited to warranties of the FirePro Xtinguish products for their fitness for a particular purpose.

Limitation of Liability

In no event, regardless of cause, shall Hochiki America Corporation be liable for any indirect, special, incidental, punitive, or consequential damages of any kind, even if advised of the possibility of such damages.

Any questions concerning the information presented in this manual should be addressed to:

Hochiki America Corporation

7051 Village Drive Suite 100
Buena Park, CA 90621
United States of America

Phone: 1-(714)-522-2246, Fax: 1-(714)-522-2268
E-mail: technicalsupport@hochiki.com

Note: this manual quotes directly from NFPA standards, including NFPA 2010 (2015 Edition) and NFPA 72 (2010 Edition). These standards, along with other national and local codes and requirements, must be carefully followed at all times during all phases of system design, installation, operation and maintenance.

The FirePro Xtinguish and HCVR-3/eLAN systems must be installed, serviced and maintained only by Hochiki America factory-trained and authorized technicians.

2 Administration

2.1 Scope

This manual is a comprehensive guide that contains all the necessary information to design, install, operate and maintain a FirePro Xtinguish condensed aerosol fire extinguishing system for total flooding applications.

This manual does not address information related to fire detection.

2.2 Purpose

This manual is prepared and intended for use by those charged with purchasing, designing, installing, operating, and maintaining condensed aerosol fire extinguishing systems. This manual provides basic guidance designed to supplement factory-certified training, with the goal that the system will function as intended for its lifetime. Authorized Hochiki training is necessary and required to design, install, operate and maintain the FirePro Xtinguish system! Do not attempt to install or service this system if you have not been provided with authorized training!

The requirements of this manual are considered necessary to provide a sufficient level of protection from loss of life and property from fire. The manual reflects the state of the art at the time it was issued.

2.3 Trademark and Patent

FirePro Xtinguish condensed aerosol fire extinguishing systems for total flooding applications is a registered trade mark of **Hochiki America Corporation**

FirePro Xtinguish condensed aerosol fire extinguishing systems for total flooding applications is a proprietary patent of:

Celanova Limited,

Cyprus Registered Company, Certificate of Incorporation no. HE 142136
6, Koumandarias & Spyrou Araouzou Str.
Tonia Court II, 6th Floor,
3036 Limassol
Cyprus

P.O.Box 54080 Limassol-3720, CYPRUS
Phone: +357 25 379999, Fax: +357 25 354432

2.4 Units and Formulas

Metric units of measurement in this manual are in accordance with the modernized metric system known as the International System of Units (SI). See IEEE/ASTM SI 10, Standard for Use of the International System of Units (SI): The Modern Metric System.

The values in this manual are given in SI. If followed by an equivalent value in other units, the first stated in SI is to be considered as the requirement; the equivalent value in other units could be approximate.

2.5 Referenced Publications

Referenced Publications as per NFPA 2010 shall apply to this manual. See Appendix "E"

2.6 Definitions

Definitions as per NFPA 2010 shall apply to this manual. See Appendix "F"

3 Environmental Summary

3.1 Significant New Alternatives Policy (SNAP List)

Submission to the U.S. Environmental Protection Agency's (EPA) SNAP Program. The SNAP Program was originally outlined in 59 FR 13044.



Significant New Alternative Policy

SNAP List Listed

Protection of Stratospheric Ozone: Listing of Substitutes for
Ozone-Depleting Substances--Fire Suppression and Explosion
Protection

Direct Final Rule – Acceptable Substitute:

Powdered Aerosol E

The official EPA document, issued by the Federal Register, is available at Vol. 71, No. 187/ Wednesday, September 27, 2006/ Rules and Regulations.

Under paragraph II, Listing Decisions: Fire Suppression and Explosion Protection – Total Flooding, at pages 56363/56364.

C. Powdered Aerosol E – Acceptable subject to use conditions.

3.2 Condensed Aerosol Environmental Parameters

Environmental parameters	FirePro Xtinguish
<p style="text-align: center;">ODP (Ozone Depletion Potential)</p>	Zero
<p style="text-align: center;">GWP (Global Warming Potential)</p>	Zero
<p style="text-align: center;">ALT (Atmospheric Life Time)</p>	Negligible
<p style="text-align: center;">Toxicity for human life</p>	Very low within the parameters for use
<p style="text-align: center;">Electrical conductivity</p>	Nil up to 75KV
<p style="text-align: center;">Corrosion</p>	Negligible within the parameters for use
<p style="text-align: center;">Extinguishing efficacy</p>	High
<p style="text-align: center;">Oxygen depletion after agent discharge</p>	Negligible within the parameters for use

4 Safety Summary

For Material Safety Data Sheet refer to Appendix A

4.1 General

The discharge of an aerosol extinguishing system could potentially create a hazard to personnel due to the nature of the aerosol. Unnecessary exposure of personnel to the agent, the by-products generated by the fire, and the fire itself should be avoided.

4.1.1 Health Effects

The potential adverse health effects are minimal as:

- Hazard for humans related to the FPC (**FirePro** solid aerosol forming compound) has not been found.
- Hazard to humans related to the aerosol released by the reaction of the solid compound (FPC) have not been established because the TLV's are not applicable. However, it is reputed that hazards to humans are not present when the aerosol is applied as guided by this manual.
- Signs and symptoms related to the aerosol phase are only referred to for acute exposure and /or chronic overexposure. In a real life situation the exposure to the generated aerosol will only occur accidentally and the exposure time will be very short, as in the event of an accidental or unexpected discharge when an occupant of the protected space has not evacuated previously. The aerosol extinguishing system shall be installed in normally unoccupied spaces and /or in spaces where personnel may be present utilizing suitable safeguards.

4.2 Hazards to Personnel

4.2.1 Potential Hazards

Potential hazards to be considered for individual systems in the protected space and other areas where the aerosol agent can migrate are the following:

- **Noise:**
The discharge of a system or aerosol generator may cause noise loud enough to be startling but insufficient to cause traumatic injury.
- **Turbulence:**
The high-velocity discharge from generator outlets may cause enough turbulence inside the protected enclosure to move unsecured paper and light objects.
- **Reduced Visibility**
When activated, the condensed aerosol generators reduce visibility both during and after the discharge period.
- **Thermal hazard:**
The condensed aerosol discharges at elevated temperatures. Depending on the intended application(s) of the aerosol system, the temperature and minimum clearance from the discharge outlet are specified by the generators' data sheets. Immediately after discharge, the aerosol generators can be hot; protective gloves should be worn by personnel handling generators after discharge.
- **Eye irritation:**
Direct contact with the aerosol solid particles being discharged by the system can result in irritation of the eyes. Exposure of the condensed aerosol to the eyes should be avoided.

4.2.2 Pre-Discharge Alarms and Time Delay

Human exposure to the **FirePro Xtinguish** condensed aerosol agents shall be prevented by providing a warning of a pending discharge, and a delay prior to the discharge, to allow personnel to exit the protected space. Suitable exits shall be provided to assure safe egress of personnel, in case of failure of the pre-discharge alarm and/or the time delay.

4.2.3 Egress

Suitable egress shall be provided to allow the personnel to exit the protected space within the time delay. The effect of reduced visibility on egress time shall be considered.

4.2.4 Reduced Visibility

The discharged **FirePro Xtinguish** condensed aerosol will cause occupants to evacuate the protected space under conditions of low visibility. Appropriate safety measures shall be used so that occupants can evacuate safely. The safety measures shall include, but are not limited to:

- personnel training,
- goggles,
- audio devices,
- floor mounted directional lighting,
- evacuation plans and exit drills.

4.2.5 Toxicity

See the Material Safety Data Sheet contained in Appendix A and the information in section 3.2 of this manual.

4.2.6 Thermal Hazards

FirePro Xtinguish condensed aerosol generators shall not be employed at less than the minimum safe distance from personnel and combustible materials. See the aerosol generator datasheets for minimum safe distance information.

Protective gloves shall be worn by personnel removing discharged aerosol generators.

5 Condensed Aerosol Fire Extinguishing Action

Traditionally, there were three distinct elements assumed as necessary for combustion: heat, fuel, and oxygen, popularly known as the “fire triangle”.

Typical fire extinguishment involves removing the fuel from the fire, limiting oxygen to the fire (smothering), or removing the heat (quenching).

This physical theory had to be modified as halons became more widely used and better understood.

The halons, as well as other agents like the **FirePro Xtinguish** condensed aerosol, do not extinguish fire in any of these ways, but instead break up the uninhibited chain reaction of the combustion process. This extinguishing mechanism is not completely understood, yet there is definitely a chemical reaction that interferes with the combustion process by removing the active chemical species involved in the flame chain reaction.

Upon activation, the FPC (patented solid compound contained in the **FirePro** condensed aerosol generators), immediately starts a chemical reaction that in few seconds produces condensed dry aerosol in the discharge density defined by the system designer (i.e. potassium compounds, K_2CO_3 , H_2O , N_2 , CO_2 , and other gas particles in small quantities). The condensed aerosol thus generated consists of micro-sized particles of potassium compounds suspended in inert gases in an extremely high ratio between the exposed surface and their reaction mass.

The **FirePro Xtinguish** condensed aerosol then remains in suspension for a relatively long time into the protected volume, allowing its active inhibitor to flow into the combustion core transported by its own natural convection currents and breaking the chain reaction upon flame contact with extremely high efficiency.

Potassium is an alkaline metal and requires the least amount of energy for ionization because of its very low ionization potential. Therefore a certain amount of energy is removed from the combustion itself to eliminate the atom's electrons during this ionization process. This is the physical action of the extinguishing process of **FirePro Xtinguish** condensed aerosol.

The chemical process of the condensed aerosol fire extinguishment is characterized by certain reactions in rapid sequence taking place between atoms and fragments of unstable molecules, which is called “chain reactions of radicals”.

Since the radicals are unstable, they tend to reach a final stable condition. The stable final products, among others, are carbon dioxide (CO_2) and water (H_2O).

The potassium atoms derived by the disassociation of the potassium compounds contained in the **FirePro Xtinguish** condensed aerosol, react during combustion with the free radicals of unstable hydroxides forming potassium hydroxide (KOH), which is a very stable compound.

At this stage the chain reaction of the free radicals is halted and the flame is extinguished.

The reaction sequence is shown on the following page.

5.1 FirePro Xtinguish Condensed Aerosol Fire Extinguishing Reaction Sequence

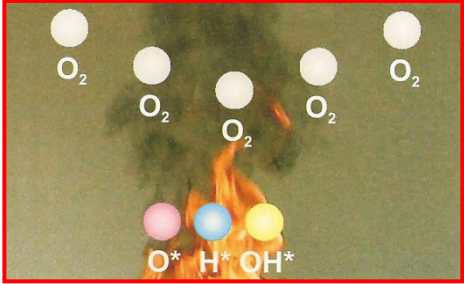
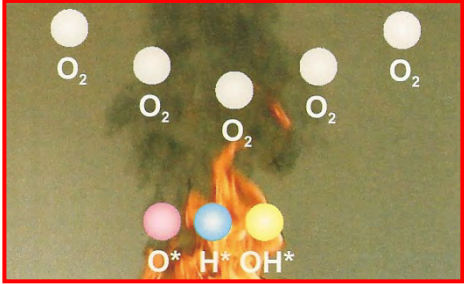
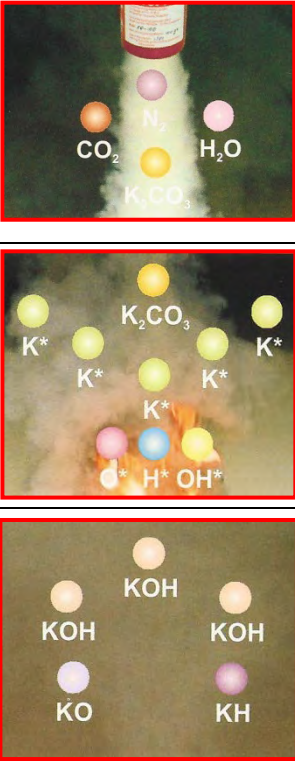
<p>Oxidation of hydrogen in the flames:</p> $\text{H}_2 + \text{O}_2 \rightarrow 2 \text{OH}^\cdot$ $\text{OH}^\cdot + \text{H}_2 \rightarrow \text{H}_2\text{O} + \text{H}^\cdot$ $\text{H}^\cdot + \text{O}_2 \rightarrow \text{OH}^\cdot + \text{H}^\cdot$ $\text{O}^\cdot + \text{H}_2 \rightarrow \text{OH}^\cdot + \text{H}^\cdot$	
<p>Oxidation of carbon monoxide in the flame:</p> $\text{H}_2 + \text{O}_2 \rightarrow 2 \text{OH}^\cdot$ $\text{OH}^\cdot + \text{CO}^{+\cdot} \rightarrow \text{CO}_2 + \text{H}^\cdot$ $\text{H}^\cdot + \text{O}_2 \rightarrow \text{OH}^\cdot + \text{O}^\cdot$	
<p>Therefore, in the flame, during combustion, further to water and carbon dioxide (stable), only unstable hydroxyl radicals are formed which allow the reaction to continue (phenomenon of auto catalysis).</p>	
<p>The chain reaction is interrupted by the Potassium atoms, which react with the unstable hydroxyl as follows:</p> $\text{OH}^\cdot + \text{K}^\cdot \rightarrow \text{KOH} \text{ (and flames are thus extinguished)}$ <p>Notice that the potassium hydroxide (KOH) is formed in quantities smaller than micrograms.</p> <p>The KOH reacts further in the presence of CO_2 and form K_2CO_3.</p> <p>During this process we can verify that the extinguishing action of potassium compounds is not achieved either through smothering or quenching but through a reaction in presence of flame with consequent termination of the chain reaction.</p>	
<p>Legend:</p>	
<p>H_2</p>	<p>Hydrogen stable</p>
<p>O_2</p>	<p>Oxygen stable</p>
<p>OH^\cdot</p>	<p>Hydroxyl radicals unstable</p>
<p>H_2O</p>	<p>Water stable</p>
<p>H^\cdot</p>	<p>Hydrogen atoms unstable</p>
<p>O^\cdot</p>	<p>Oxygen atoms unstable</p>
<p>$\text{CO}^{+\cdot}$</p>	<p>Carbon monoxide unstable</p>
<p>CO_2</p>	<p>Carbon dioxide stable</p>

5.2 Particle Distribution in the Aerosol Phase

The **FirePro Xtinguish** condensed aerosol phase consists of a gas phase with micro sized solid particles in suspension.

Laser beam diffraction tests analyses have shown the correlation between solid and gaseous components of 52% solid and 48% gas.

The percentage distribution of the solid compounds as per their diameter's size expressed in microns is as follows

Particle's size (dia. μm)	Percent %
< 1	52
1 ÷ 2	19
2 ÷ 5	17
> 5	12

6 FirePro Xtinguish Condensed Aerosol Fire Use and Limitations

6.1 Systems

The **FirePro Xtinguish** condensed aerosol systems shall be installed to protect hazards within the limitations that have been established by this installation manual.

6.2 Use and Application

FirePro Xtinguish condensed aerosol extinguishing systems are effective in extinguishing Class A, B, and C fires.

FirePro Xtinguish condensed aerosol extinguishing systems provide an efficient and effective means to extinguish gas and liquid fires, burning solid substances, burning substances derived from hydrocarbons (natural gas, oil products, flammable lubricants, etc.), as well as fires in electrical equipment with an operating voltage not exceeding 75,000 Volts.

FirePro Xtinguish condensed aerosol extinguishing systems shall not be used to protect areas, hazards or spaces containing flammable liquids, vapors, or dusts that may form an explosive air/fuel mixture unless they have been tested to the satisfaction of the authority having jurisdiction and/or proven by experimental testing carried out by a third party laboratory.

FirePro Xtinguish condensed aerosol extinguishing systems shall not be used on metal fires, on substances generating self-sustaining combustion, and on the following substances unless they have been tested to the satisfaction of the authority having jurisdiction and/or proven by experimental testing carried out by a third party laboratory.

- ▶ Deep seated fires in Class A materials
- ▶ Class D fires:
 - ▶ D1 - light metals (aluminum - Al; magnesium - Mg Titanium ...)
 - ▶ D2 - alkali metals (potassium - K; sodium - Na; lithium - Li ...)
 - ▶ D3 - organic-metallic compounds (methyl magnesium chloride - CH₃MgCl; methyl magnesium iodide - CH₃MgI; triethyl aluminum - (C₂H₅)₃Al...)
- ▶ Metal hydrides (aluminum hydride - AlH₃) lithium hydride - LiH ...)
- ▶ Reactive metals such as, lithium, sodium, potassium, magnesium, titanium, zirconium, uranium, and plutonium.
- ▶ Chemical compounds containing oxidizers such as sodium chlorate or sodium nitrate.
- ▶ Certain chemicals or mixtures of chemicals, such as cellulose nitrate and gunpowder, that are capable of rapid oxidation in the absence of air
- ▶ Chemicals capable of undergoing auto-thermal decomposition, such as certain organic peroxides and hydrazine

The above list may be not exhaustive. Contact **Hochiki America Corporation** or your local **Hochiki America** dealer if additional information is required.

The **FirePro Xtinguish** condensed aerosol generators shall not be employed at less than the minimum safe distances specified in the present manual (see the aerosol generator datasheets for details).

The minimum safe distance between the **FirePro Xtinguish** condensed aerosol generator discharge ports and personnel shall be based on an aerosol agent discharge temperature, at that distance, not exceeding 75°C (167° F). See Appendix C for generator datasheets and minimum safe distance information.

The minimum safe distance between the **FirePro Xtinguish** condensed aerosol generator discharge ports and combustible materials shall be based on an aerosol agent discharge temperature, at that distance, not exceeding 200°C (392° F). See Appendix C.

The total flooding **FirePro Xtinguish** condensed aerosol extinguishing system shall be installed in enclosures protecting the hazards that allows the specific agent design application density to be achieved and maintained for the specified period of time.

Where the **FirePro Xtinguish** condensed aerosol extinguishing agents are used in spaces containing sensitive equipment, the potential adverse effects of **FirePro Xtinguish** condensed aerosol particulate residue shall be considered.

6.3 Environmental Factors

Despite that condensed aerosol extinguishing systems do not represent any significant environmental concern the unnecessary emission of aerosol extinguishing systems shall be avoided. All phases of design, installation, testing, and maintenance of condensed aerosol extinguishing systems shall be performed with the goal of no emission to the environment.

6.4 Compatibility with Other Agents

Unless specifically approved, systems employing the simultaneous discharge of different agents to protect the same enclosed space shall not be permitted. Where unrelated extinguishing or suppression systems are provided, and can operate prior to, or during the hold time of the **FirePro Xtinguish** condensed aerosol extinguishing systems, the other agent shall not adversely affect the aerosol.

7 Condensed Aerosol Generator Description

7.1 General Description of the Aerosol Generator Units

The range of condensed aerosol generators is shown in the appendix “B”.

The condensed aerosol generator is formed by the following main components:

7.1.1 The Solid Aerosol-Forming Compound FPC:

The solid aerosol-forming compound FPC is the originator of the condensed extinguishing aerosol (generated by the FPC activation):

Upon actuation, the solid aerosol-forming compound FPC will undergo a combustion reaction generating the fire extinguishing condensed aerosol.

FirePro Condensed Aerosol composition			
Compound	Chemical Formula	CAS #	% by Weight
Gas			
Carbon Dioxide	CO ₂	124-38-9	13%-14%
Nitrogen	N ₂	7727-37-9	21%-22%
Water Vapor	H ₂ O	7732-18-5	10%-12%
Carbon Monoxide	CO		1%-2%
Methane	CH ₄		
Hydrogen	H ₂		
Particulate			
Potassium Carbonate	K ₂ CO ₃	584-08-7	47%-49%
Potassium Nitrate	KNO ₃	7757-79-1	2%-3%
Potassium Chloride	KCl	7447-40-7	< 1%
Other elements	See KEMA report	---	< 1%

7.1.2 The Ignition Device (Initiator):

FirePro Xtinguish condensed aerosol generators are initiated by applying the appropriate voltage across the electric wire terminals of the aerosol generator so that the solid aerosol forming compound will be activated and transformed into the condensed aerosol (the extinguishing agent).

7.1.3 The Cooling Mechanism:

FirePro Xtinguish condensed aerosol generators are equipped with a physical heat-absorbing mechanism (the cooling mechanism). The generated aerosol will exit the generator via the cooling mechanism, and the condensed aerosol will be cooled down before flooding the protected volume.

7.1.4 The Housing (External Steel Casing):

The **FirePro Xtinguish** condensed aerosol generator casing is formed by a non-pressurized container. The aerosol is generated by a reaction (combustion process) of the solid aerosol-forming compound FPC, and the condensed aerosol is then carried by gases generated by this reaction.

7.1.5 The Mounting Brackets:

Mounting brackets are provided for each **FirePro Xtinguish** condensed aerosol generator, allowing the generator appropriate orientation. The mounting brackets are constructed by galvanized carbon steel plate of suitable shape and strength to hold the **FirePro Xtinguish** condensed aerosol generators.

7.1.6 The End Plate Discharge Outlets:

The end plate discharge outlet holes ensure a smooth and fast discharge of the aerosol.

7.1.7 The Seal

A special membrane of adhesive polymer sheet is applied internally at the discharge outlets, protecting against the entry of moisture, dirt, or anything undesirable. The membrane will be broken by the generated **FirePro Xtinguish** condensed aerosol when the unit is activated.

7.2 Aerosol Generator Components

FirePro Xtinguish Unit Components



FirePro Xtinguish Unit Designations

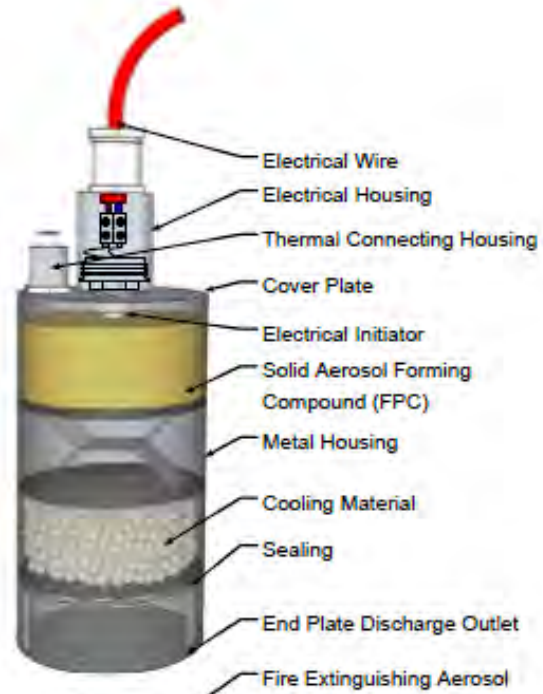

FirePro Xtinguish Initiator (electrical activator)

The initiator is connected to the activation power circuit (minimum current required 0.8 A for 3 - 4 seconds) by heat resistant wires. The activation power will heat up the electric coil (4) thus the (5) solid aerosol forming compound (FPC) will initiate an exothermal reaction. The heat developed will transfer through the cylinder (7) outlets starting the exothermal reaction of the (9) FPC, thus the thermal energy will be sufficient to start the reaction of the whole mass of FPC contained inside the aerosol generator, transforming the FPC into a particulate aerosol and carrier gases.

Initiator cut-off view	Legend	
	1	heat resistant wires (feed)
	2	steel housing
	3	polymeric resin
	4	electric coil
	5	FPC (solid compound)
	6	chemical stabilizer
	7	cylinder with 2 outlets
	8	sealing
	9	FPC (solid compound)
	10	lacquered surface
Electrical values		
Bridge Resistance	1.6-3.0 Ohms (Ω)	
Ignition Pulse	From 1- 2 mWs/ Ω	
No Fire Value	≤ 20 mA t = 300s	
Direct Current (DCV)	6-36V / 0.8 A	
Ignition Time	3 - 4 sec.	
Working Temperature (not to exceed)		
Deployment Temperature	-54° C to 100° C	
Storage Temperature	-54° C to 54° C	



The initiator is a standard component of all the aerosol generators

8 Total Flooding Systems Design

8.1 Working Documents

The design of a **FirePro Xtinguish** condensed aerosol total flooding fire extinguishing system shall be prepared only by a person qualified and experienced in designing extinguishing systems, in accordance with the advice of the authority having jurisdiction.

Deviation from the working documents shall require the permission and agreement of the authority having jurisdiction.

The working documents shall include, as a minimum requirement, the following:

8.1.1 Specifications

- ▶ Designation of the authority having jurisdiction,
- ▶ Variances from the standard to be permitted by the authority having jurisdiction,
- ▶ Design criteria,
- ▶ System sequence of operation,
- ▶ Functional testing to be performed after installation of the system,
- ▶ System owner/user training requirements.

8.1.2 Working Plans

- ▶ Point of compass and symbol legend.
- ▶ Name of owner and identification of the occupant/user;
- ▶ Location of building, including address;
- ▶ Location and construction characteristics of protected enclosure walls and partitions; location of fire walls.
- ▶ Enclosure cross-section, full height or schematic diagram, including raised access floor and suspended ceiling;
- ▶ Description of occupancies and hazards to be protected; identification of enclosures normally occupied
- ▶ Description of enclosures/facilities/exposures surrounding the enclosure.
- ▶ Plan view of protected area showing enclosure partitions (full and partial height); detection, alarm, and control system including all devices and schematic of wiring interconnection; end-of-line device locations; location of controlled devices such as dampers and shutters; location of instructional signage.
- ▶ Type of **FirePro Xtinguish** condensed aerosol generators used; including nominal capacity expressed as agent solid compound mass.
- ▶ **FirePro Xtinguish** condensed aerosol design application density.
- ▶ Drawings indicating the location and distribution of **FirePro Xtinguish** condensed aerosol generators.
- ▶ Equipment list of materials showing device identification, model or part number, quantity and description;
- ▶ Description of fire detection, actuation and control systems
- ▶ Enclosure pressurization report and venting calculations where applicable;
- ▶ Description of wire or cable used including classification, gauge [American Wire Gauge (AWG)], shielding, number of strands in conductor, conductor material, and color coding schedule, with the segregation requirements of various system conductors clearly indicated and the required method of making wire terminations detailed.
- ▶ Description of the detector mounting.
- ▶ Scale drawing showing the layout of the annunciator panel graphics if required by the authority having jurisdiction.
- ▶ Complete step-by-step description of the system sequence of operations including functioning

- of abort and maintenance disconnect switches, delay timers, and emergency power shutdown.
- ▶ Point-to-point wiring schematic diagrams showing all circuit connections to the system control panel, to the graphic annunciator panel and to external or add-on relays.
 - ▶ Complete calculations to determine the size of backup batteries and method used to determine number and location of audible and visual indicating devices and number and location of detectors.
 - ▶ Minimum clearances to combustible materials and the means of egress.
 - ▶ Details of any special features.

Information shall be submitted for approval to the authority having jurisdiction pertaining to the location and function of:

- ▶ Detection devices,
- ▶ Operating devices,
- ▶ Auxiliary equipment,
- ▶ Electrical circuitry, if used.

All the apparatus and devices used shall be identified.

Any special features shall be explained.

The as-built installation drawings and the instruction and maintenance manual that includes a full sequence of operations.

A full set of drawings and calculations shall be maintained on site.

8.1.3 Approval of Plans

Plans and calculations shall be approved prior to installation.

Where field conditions necessitate any change from approved plans, the change shall be approved prior to implementation.

When such changes from approved plans are made, the working plans shall be updated to accurately represent the system as installed.

8.2 Enclosure

In the design of a **FirePro Xtinguish** condensed aerosol total flooding fire extinguishing system, the integrity of the protected enclosure shall be considered.

The area of non-closable openings in the protected enclosure shall be kept to a minimum.

8.2.1 Loss of Agent

To prevent loss of agent through openings to adjacent hazards or work areas, openings shall be permanently sealed or equipped with automatic closures.

Where reasonable confinement of agent is not practicable, protection shall be expanded to include the adjacent connected hazards or work areas or additional agent shall be introduced into the protected enclosure using an extended discharge configuration.

Forced-air ventilating systems shall be shut down or closed automatically where their continued operation would adversely affect the performance of the fire extinguishing system or result in propagation of the fire.

Completely self-contained recirculation ventilation systems shall not be required to be shut down.

The volume of the ventilation system and associated ductwork shall be considered as part of the total hazard volume when determining the quantity of agent.

The protected enclosure shall have the structural strength and integrity necessary to contain the

agent discharge.

If the developed pressures present a threat to the structural strength of the enclosure, venting shall be provided to prevent excessive pressures.

8.3 Condensed Aerosol System Agent Supply

8.3.1 Quantity

- ▶ **Primary FirePro Xtinguish condensed aerosol Agent Supply.**
The primary condensed aerosol agent supply shall be determined by calculating the required mass of the solid aerosol forming compound needed to meet the design application density.
- ▶ **Reserve FirePro Xtinguish condensed aerosol Agent Supply.**
Where required, a reserve condensed aerosol agent supply shall consist of as many multiples of the primary agent supply as the authority having jurisdiction considers necessary.

8.4 Design Application Density

8.4.1 Determining Design Application Density

The **FirePro Xtinguish** condensed aerosol extinguishing application density shall be used in determining the minimum design application density for a particular fuel. For combinations of fuels, the extinguishment value for the fuel requiring the greatest condensed aerosol design application density shall be used, unless specific tests are made on the actual mixture.

8.4.2 Fuel Types:

- ▶ **Class B Fuels:**
The **extinguishing application density** of **FirePro Xtinguish** condensed aerosol for **Class B fuels** has been determined by test as per UL 2775.
The **minimum design application density for a Class B fuel hazard** is the extinguishing application density multiplied by a safety factor of 1.3.
- ▶ **Class A Fuels:**
The **extinguishing application density** of **FirePro Xtinguish** condensed aerosol for **Class A fuels** has been determined by test as per UL 2775.
The **minimum design application density for a Class A Fuels** fire hazard is the extinguishing application density multiplied by a safety factor of 1.3.
- ▶ **Class C Fuel:**
The **minimum design application density** of **FirePro Xtinguish** condensed aerosol for **Class C hazards** shall be at least that for the Class of fire hazard being protected ""
- ▶ **Fuel combination:**
For combinations of Class A and B fuels the design application density shall be the value for the fuel requiring the greatest design application density.

Table 8.4.1		
Class of Fire	Extinguishing application density	Minimum design application density
Class B Fuels:	84 g/m ³	109.20 g/m ³
Class A Fuels:	84 g/m ³	109.20 g/m ³
Class C Fuel:	84 g/m ³	109.20 g/m ³

8.5 Total Flooding Quantity

8.5.1 Quantity Calculation

The mass of condensed aerosol forming compound required shall be calculated from the following formula:

$$m = d_a \times f_a \times V$$

where

- ▶ m = total flooding quantity, in [g(lb)]
- ▶ d_a = design application density, in [g/m³ (lb/ft³)]
- ▶ f_a = additional design factors (see 8.5.2)
- ▶ V = protected volume, [m³ (ft³)]

8.5.2 Additional Design Factors

In addition to the **FirePro Xtinguish** condensed aerosol agent quantity determined by the design application density, additional quantities of agent are required through the use of additional design factors to compensate for any special conditions that would affect the extinguishing efficiency.

The designer shall assign and document other design factors for each of the following:

1. Non- closable openings and their effects on design application density
2. Height of protected volume (As per maximum height related to each generator)
3. Re-ignition from heated surfaces
4. Fuel type, configurations, scenarios not fully accounted for in the extinguishing application density, enclosure geometry, and obstructions and their effects on distribution.

8.5.3 Duration of Protection

The **FirePro Xtinguish** condensed aerosol agent design application density shall be maintained for the specified period of time to prevent re-ignition of the fire before effective emergency action can be taken by trained personnel.

8.5.4 Discharge Time

For the **FirePro Xtinguish** condensed aerosol generator discharge time see the generator Data Sheets.

8.5.5 Extended Discharge

When an extended discharge is necessary to maintain the design application density for the specified period of time, additional condensed aerosol agent quantities shall be applied.

When an extended discharge is necessary, the rate shall be sufficient to maintain the desired factor for the required hold time. In such applications the **FirePro Xtinguish** condensed aerosol generators may be activated in sequence.

8.5.6 Safety Vents

When **FirePro Xtinguish** condensed aerosol is discharged into a closed volume, a certain overpressure may be developed due to the amount of gases generated and the effects of increased temperature of the atmosphere.

Later, the combined volume of aerosol and air will become greater than the initial room volume; the final result will increase the pressure or will exhaust the excess volume through vent openings. The air temperature is increased during the discharge but will return to normal levels as heat is adsorbed

by solid surfaces in the room.

The designer/installer shall provide reliable calculations for venting requirements for each system if applicable, since experience has shown that most ordinary rooms have a sufficient leakage through cracks around doors and windows, and a general porosity that will prevent noticeable pressure build up.

In rooms that may be sealed or close to being sealed, a safe vent area for low-strength structures can be estimated on the basis of the discharge flow rate.

8.5.7 Generator Choice and Location

The **FirePro Xtinguish** condensed aerosol generators shall be suitable for the intended purpose and shall be placed within the protected enclosure in compliance with the instruction and limitations contained in this manual with regard to spacing, floor coverage, thermal clearances and alignment.

The type of **FirePro Xtinguish** condensed aerosol generators selected, their number, and their placement shall be such that the design application density will be established in all parts of the hazard enclosure.

8.6 Preparing the Enclosure Prior to Aerosol Discharge

The following steps are necessary prior to discharge of the FirePro Xtinguish aerosol:

- 1) HVAC systems must be shut down. This allows the aerosol to reach the fire as quickly as possible. May be automatically controlled by the fire alarm panel.
- 2) Power must be removed from all equipment, computers, servers, etc. This guarantees that there will be no short-circuit situations following activation. May be automatically controlled by the fire alarm panel.
- 3) Ventilate the room as soon as possible after discharge. This process will extract much of the discharged aerosol and has the effect of reducing condensation rate and humidity.

8.7 Working in a Room or Enclosure Protected by FirePro Xtinguish

To avoid or reduce the possibility of unwanted false aerosol discharge as a result of human error, it is important to disable the automatic detection network and/or isolate the **FirePro Xtinguish** system prior to the start of contractual work. The control panel will indicate the off-normal condition while the system is disabled. After the work has been completed and the enclosure returned to a normal condition, the system must be enabled.

Hochiki America Corporation will not be responsible or liable for any damages caused by accidental discharge.

9 Condensed Aerosol Fire Extinguishing System Arrangement

The **FirePro Xtinguish** condensed aerosol generators and ancillary system components shall be arranged to allow easy inspection and maintenance activities, minimizing the interruption of protection.

FirePro Xtinguish condensed aerosol generators shall not be located where they can be mechanically damaged, exposed to chemicals, or to adverse weather conditions which may render them inoperative. Suitable protective provisions shall be adopted, if necessary.

FirePro Xtinguish condensed aerosol generators shall be securely installed following the guidance given by this manual.

9.1 Minimum Safe Distances

Minimum safe distances:

- ▶ **FirePro Xtinguish** condensed aerosol generators shall not be installed at less than the minimum safe distances as specified in the **FirePro Xtinguish** condensed aerosol generator data sheets. The generator datasheets are in Appendix C of this manual.
- ▶ The minimum safe distance between the **FirePro Xtinguish** condensed aerosol generator casing and personnel shall be the distance from the generator casing to where the temperature does not exceed 75°C (167°F) during and after discharge.
- ▶ The minimum safe distance between the **FirePro Xtinguish** condensed aerosol generator casing and combustible materials shall be the distance from the generator casing to where the temperature does not exceed 200°C (392°F) during and after discharge.

9.2 Safety Requirements

Personnel shall not enter a protected space during or after the agent discharge.

Safeguards shall be provided to ensure prompt evacuation of personnel prior to system discharge, and to prevent entry or re-entry into the protected enclosure after system discharge.

There shall be provided a means for prompt rescue of any trapped personnel, including the following:

- a. Provision for adequate egress pathways, and procedures to keep them clear at all times
- b. Provision for emergency lighting and directional signs if necessary to ensure quick, safe evacuation.
- c. Provision for alarms in such areas that will operate immediately on detection of the fire.
- d. Provision for only outward-swinging, self-closing doors at exits from hazardous areas and, where such doors are latched, panic hardware shall be installed.
- e. Provision for continuous alarms at entrances to such areas until the atmosphere has been restored to normal.
- f. Provision for warning and instruction signs at entrances to and inside such areas. These signs should inform persons in or entering the protected area that an aerosol system is installed and shall contain additional instructions pertinent to the conditions of the hazard.
- g. Provision for the prompt discovery and rescue of persons rendered unconscious in such areas. This should be accomplished by having such areas searched immediately by trained personnel equipped with proper breathing equipment. Self-contained breathing equipment and personnel trained in its use and in rescue practices, including cardiopulmonary resuscitation, should be readily available.
- h. Provision for instruction and drills for all personnel in or in the vicinity of such areas, including maintenance or construction people, to ensure their correct action when a **FirePro Xtinguish** condensed aerosol system operates.

- i. Provision for prompt ventilation of such areas, including forced ventilation if necessary. Use caution to avoid spreading condensed aerosol residue to other areas.
- j. Smoking should be prohibited until the atmosphere has been determined to be free from the **FirePro Xtinguish** condensed aerosol.
- k. Removal of **FirePro Xtinguish** condensed aerosol generators after discharge shall be done according to the instructions given in this manual. Protective clothing, gloves and goggles should be worn, including a respirator or mask if necessary.
- l. Any further provision or safeguards shall be adopted if a particular situation indicates it as necessary to prevent injury or death.
- m. Specific attention shall be given to the possibility that the **FirePro Xtinguish** condensed aerosol may potentially spread to adjacent areas outside of the protected space.

9.3 Electrical Clearances

All system components shall be located to maintain no less than minimum clearances from energized electrical parts as per:

- ANSI C2
- NFPA 70
- 29 CFR 1910, Subpart S
- Canadian Electrical Code, CSA C22.1

Where the design basic insulation level (BIL) is not available, and where nominal voltage is used for the design criteria, the highest minimum clearance listed for this group shall be used.

The selected clearance to ground shall satisfy the greater of the switching surge or BIL duty, rather than being based on nominal voltage.

The clearance between non insulated, energized parts of the electrical system equipment and any portion of the **FirePro Xtinguish** condensed aerosol extinguishing system shall not be less than the minimum clearance provided elsewhere for electrical system insulations on any individual component

9.4 Precautions While Handling the Generator Units

While handling the aerosol generators do not:

- ▶ Disassemble the **FirePro Xtinguish** condensed aerosol generators.
- ▶ Exert force of impact or carry out other actions to the **FirePro Xtinguish** condensed aerosol generators which may cause distortion and physical or other mechanical damage to the casing.
- ▶ Carry out any welding work in the vicinity of the **FirePro Xtinguish** condensed aerosol generators and/or condensed aerosol fire extinguishing system components.
- ▶ Smoke in the vicinity of **FirePro Xtinguish** condensed aerosol generators and/or **FirePro Xtinguish** condensed aerosol fire extinguishing system components.

Where a **FirePro Xtinguish** condensed aerosol generator, during handling or installation, is dropped or subjected to an impact, ensure that the electric circuit of the ignition and the other **FirePro Xtinguish** condensed aerosol generator components have not been damaged.

Where a **FirePro Xtinguish** condensed aerosol generator shows external damages to the casing it shall not be installed.

9.5 Storage and Transport

The **FirePro Xtinguish** condensed aerosol generators are classified as Hazard Class Division 9.

The units shall be transported by ships and by airfreight in accordance with the regulations and requirements applicable to the above category of cargo.

Transport by road of the **FirePro Xtinguish** condensed aerosol generators is permitted utilizing all types of transport vehicles without any restrictions.

The containers carrying the **FirePro Xtinguish** condensed aerosol generators shall be firmly secured on the vehicle and be protected against dirt, moisture and shocks.

Do not drop aerosol generators or the containers carrying them during vehicles loading/unloading operations.

The aerosol generators shall be stored in their own packaging on racks in warehouses (either heated, or unheated with natural ventilation, at a distance of at least one meter from heating appliances).

The **FirePro Xtinguish** condensed aerosol generators comply with the requirements of the U.S. Department of Transportation (DOT) and the Canadian Transport Commission, and are classified IAW 49 CFR 172.101, Subpart B or the Canadian equivalent.

9.6 Storage Conditions

- ▶ Temperature : between -54 and $+54^{\circ}\text{C}$
- ▶ Humidity : maximum 98% RH

9.7 Replacement / Removal from Service

Service life: 15 years from the manufacturing date (the date of manufacture appears on each generator)

10 Detection, Actuation, Alarm and Control Systems

This manual does not address information related to fire detection; however the following general information shall be considered. Always apply national and local code requirements.

10.1 General

Detection, actuation, alarm, and control systems shall be installed, tested, and maintained in accordance with NFPA 70, NFPA 72, NFPA 2010, and local requirements.

In Canada the equipment shall be certified to the requirements of CAN/ULC S524-01 and CAN/ULC-S 529-02.

Automatic detection and automatic actuation shall be used unless a manual-only actuation is approved by the authority having jurisdiction.

10.2 Raceways

System initiating circuits and auxiliary equipment releasing circuits shall be installed in raceways. National and local requirements shall be observed.

10.3 Automatic Detection

Automatic detection shall be a UL listed system capable of detecting and indicating heat, flame, smoke, combustible vapors, or an abnormal condition in the hazard that is likely to produce fire.

Automatic detection shall be UL listed and compatible with the control panel.

Reliable primary and secondary power sources shall be used, in compliance with national and local requirements, to provide for operation of the detection, signaling, control, and actuation of the system.

10.4 Operating Devices

Operating devices shall include system actuation devices, discharge controls, and shutdown equipment.

All operating devices shall be UL listed and compatible with the control panel.

The system actuation shall cause simultaneous operation of **FirePro Xtinguish** condensed aerosol generators.

All devices/components shall be designed to be suitable for the specific intended service and working conditions. Devices shall not be susceptible to being rendered inoperative or to accidental operation.

All devices/components shall be installed in appropriate locations or adequately protected to avoid being subject to mechanical, chemical, or any other damages that would render them inoperative.

System manual actuation/release shall be accomplished by an electrical manual release; the arrangement shall include the control equipment monitoring the battery condition, including a low battery signal/alarm.

System manual control(s) for actuation shall be located for easy accessibility at all times, including at the time of a fire.

The system manual control(s) shall be of distinct appearance and clearly recognizable for the purpose intended.

Operation of any control station shall cause the complete system to operate.

Manual controls shall not require a pull of more than 178 N (40 lb) nor a movement of more than 356 mm (14 in.) to secure operation.

At least one system manual control station for activation shall be located not more than 1.2 m (4 ft)

above the floor.

All devices for shutting down auxiliary/supplementary equipment shall be considered integral parts of the system and shall function with the system operation.

All the manual operating devices shall be identified as to the hazard they protect.

10.5 Fire Alarm Control Panel

The fire alarm control panel shall supervise the actuating devices and associated wiring and, as required, cause the system actuation.

The fire alarm control panel shall be UL listed, and shall be listed as compatible with the extinguishing system units.

Refer to the Control Panel Manual for compatibility information.

10.6 Operating Alarms and Indicators

Alarms or indicators or both shall be used to indicate the operation of the system, hazards to personnel, or failure of any supervised device.

All alarm or indicator devices shall be UL listed and compatible with the control panel.

The type (audible, visual), number, and location of the devices shall be such that their purpose is satisfactorily accomplished.

The extent and type of alarms or indicator equipment or both shall be approved.

10.7 Warning Devices

Audible and visual pre-discharge alarms shall be provided within the protected area to give positive warning of the impending discharge.

The operation of the warning devices shall continue after **FirePro Xtinguish** condensed aerosol discharge, until positive action has been taken to acknowledge the alarm and proceed with appropriate action.

10.8 Abort Switches

Where provided, the system abort switches shall be located within the protected area and shall be located near the means of egress for the area.

All abort switches shall be UL listed and compatible with the control panel.

A telephone should be located near the abort switch.

An abort switch shall not be operated unless the cause for the condition is known and corrective action can be taken.

The abort switch shall be of a type that requires constant manual pressure to cause abort.

The abort switch shall not be of a type that would allow the system to be left in an aborted mode without personnel present. In all cases the manual emergency control shall override the abort function.

Operation of the abort function shall result in both audible and distinct visual indication of system impairment.

The abort switch shall be clearly recognizable.

10.9 Alarms Indicating Failure of Supervised Devices and Equipment

Alarms indicating failure of supervised devices or equipment shall give prompt and positive indication of any failure and shall be distinctive from alarms indicating operation or hazardous conditions.

10.10 Warning and Instruction Signs

Warning and instruction signs at entrances to and inside protected areas shall be provided.

10.11 Pre-Discharge Alarms and Time Delays

For the aerosol extinguishing system, a pre-discharge alarm and time delay, sufficient to allow personnel evacuation prior to discharge, shall be provided.

For hazard areas subject to fast growth fires, where the provision of a time delay would seriously increase the threat to life and property, a time delay shall be permitted to be eliminated.

Time delays shall be used only for personnel evacuation or to prepare the hazard area for discharge.

Time delays shall not be used as a means of confirming operation of a detection device before automatic actuation occurs.

10.12 Unwanted System Operation

Care shall be taken to thoroughly evaluate and correct any factors that could result in unwanted discharges of the system.

To avoid unwanted discharge of an aerosol system during maintenance or when anyone enters the protected enclosure, a supervised disconnect switch shall be provided.

The disconnect switch shall interrupt the releasing circuit to the **FirePro Xtinguish** condensed aerosol system.

The disconnect switch shall be UL listed and compatible with the control panel.

11 Total Flooding System – Installation Examples

Figure 11.1 – Recommended FirePro Xtinguish condensed aerosol generator arrangement, ceiling

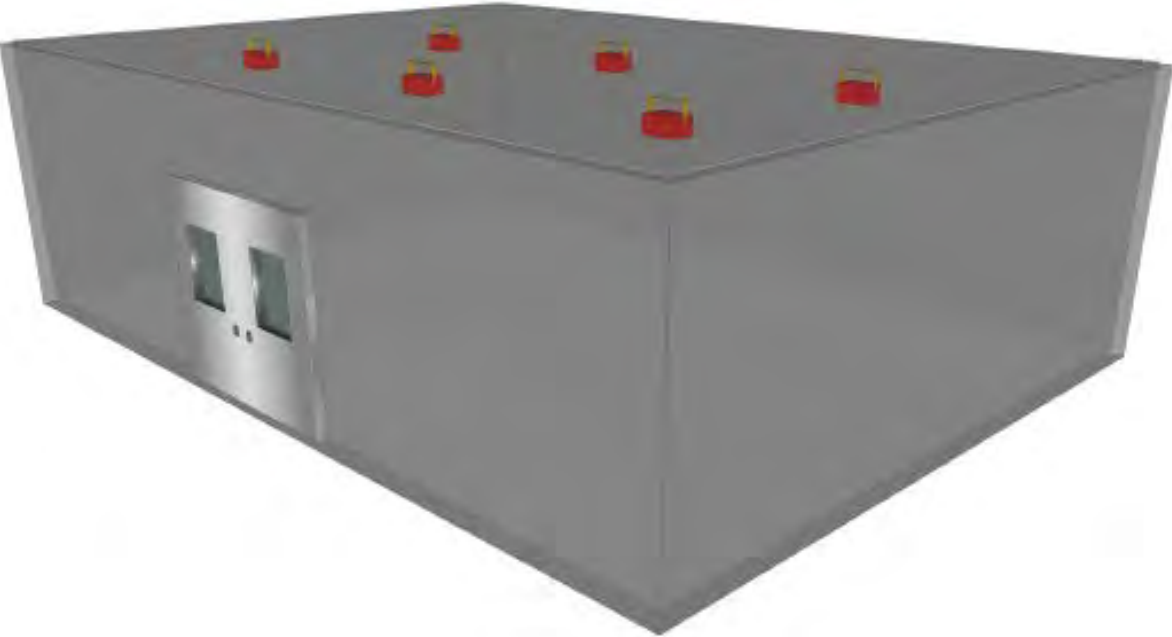

Figure 11.2 – Recommended FirePro Xtinguish condensed aerosol generator arrangement, top of side walls

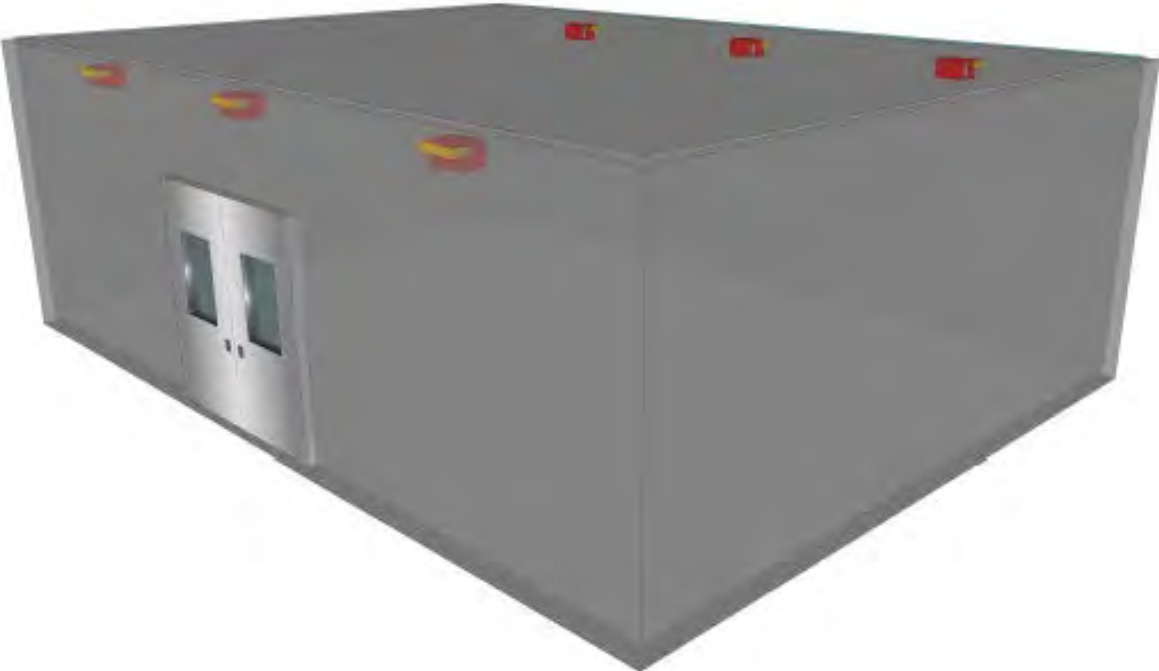

Figure 11.3 – WRONG FirePro Xtinguish condensed aerosol arrangement



The location of the generators shown above is incorrect. The generator outlets are pointing the aerosol stream in the direction of an opening. If the doors were left open at the time of generator activation, the aerosol would easily escape from the protected volume. This would nullify the aerosol design factor and possibly result in a failure to extinguish the fire.

Figure 11.4 – Allowed FirePro Xtinguish condensed aerosol arrangement



WRONG condensed aerosol arrangement

The aerosol discharge is obstructed by the equipment.

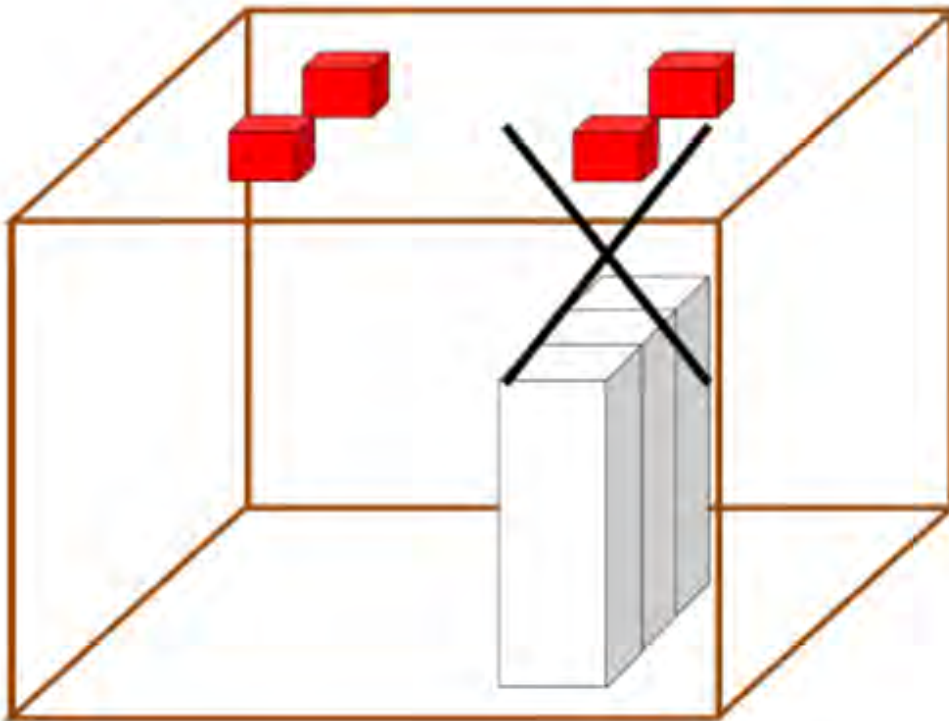

Figure 11.5 - Installation Clearance

Proper Installation - The aerosol easily reaches the likely source of the fire and homogeneous distribution is achieved

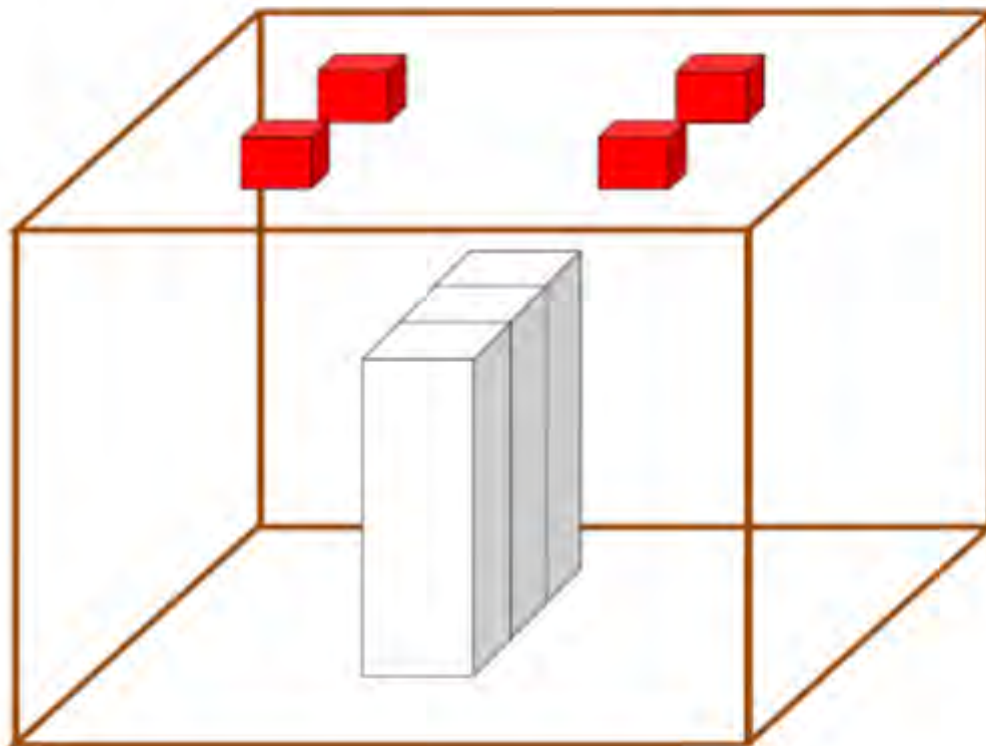

Figure 11.6

11.1 General

Do not install **FirePro Xtinguish** condensed aerosol generators close to openings.

The recommended optimal distance between the floor of the safeguarded volume and the **FirePro Xtinguish** condensed aerosol generator is reported on the condensed aerosol generator data sheets.

The discharge outlets of the **FirePro Xtinguish** condensed aerosol generators shall not be obstructed.

Minimum safe distances:

- ▶ **FirePro Xtinguish** condensed aerosol generators shall not be installed at less than the minimum safe distance as specified in the condensed aerosol generator data sheet. The generator datasheets are in Appendix C of this manual.
- ▶ The minimum safe distance between the **FirePro Xtinguish** condensed aerosol generator casing and personnel shall be the distance from the generator casing to where the temperature does not exceed 75°C (167°F) during and after discharge.
- ▶ The minimum safe distance between the **FirePro Xtinguish** condensed aerosol generator casing and combustible materials shall be the distance from the generator casing to where the temperature does not exceed 200°C (392°F) during and after discharge.

The **FirePro Xtinguish** condensed aerosol generators shall be positioned in the protected space/volume so that the aerosol flow does not obstruct or impede the evacuation of personnel.

11.2 FirePro® Condensed Aerosol Generator Installation Procedure

Warning: Before installing the FirePro Xtinguish condensed aerosol system, read this manual carefully along with the manuals and technical instructions for installation and management of the fire detection system and fire alarm control panel.

Warning: Ensure that the FirePro Xtinguish condensed aerosol generator is firmly secured!

The condensed aerosol generators are installed utilizing the brackets provided inside the package. The general installation steps are:

- A. Firmly attach the bracket(s) to the enclosure walls or ceiling, according the system design and the generator location.
- B. Check the resistance of the electric activation element. This value should be approximately 1.6 to 3.0 ohms (see Section 7.2)
- C. Connect the aerosol generator to the appropriate fire alarm control panel circuit.
- D. Complete all other connections to the fire alarm control panel. Apply power to the control panel when the installation is complete.

On completion, ensure that the FirePro Xtinguish condensed aerosol generators have been installed in the correct manner, i.e. that all requirements contained in this manual have been accomplished. Be sure to record the installation information on the installation certificate or on the technical documentation for the protected premises.

11.2.1 FNX-20 Installation Details

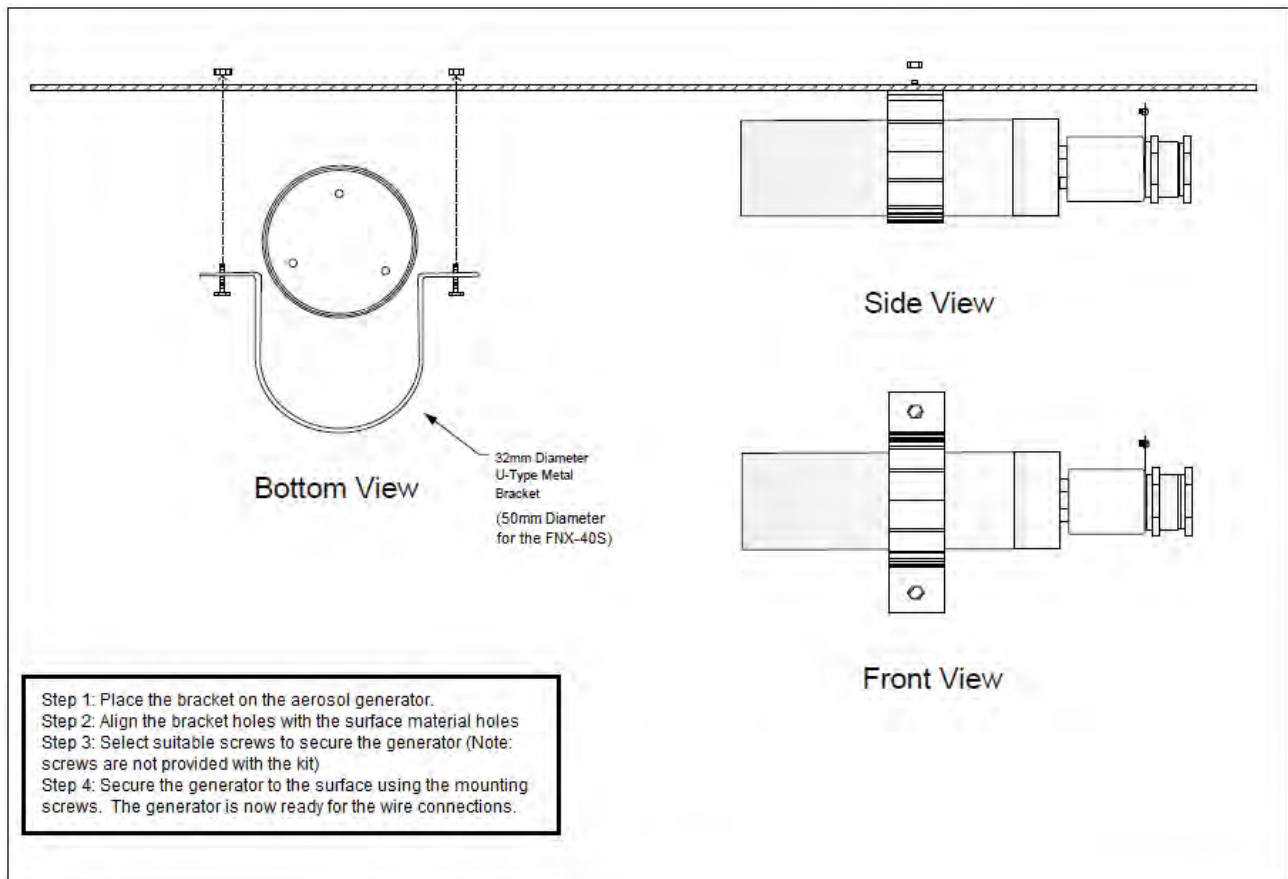

11.2.2 FNX-40 / FNX-80 / FNX-100S / FNX-200S Installation Details

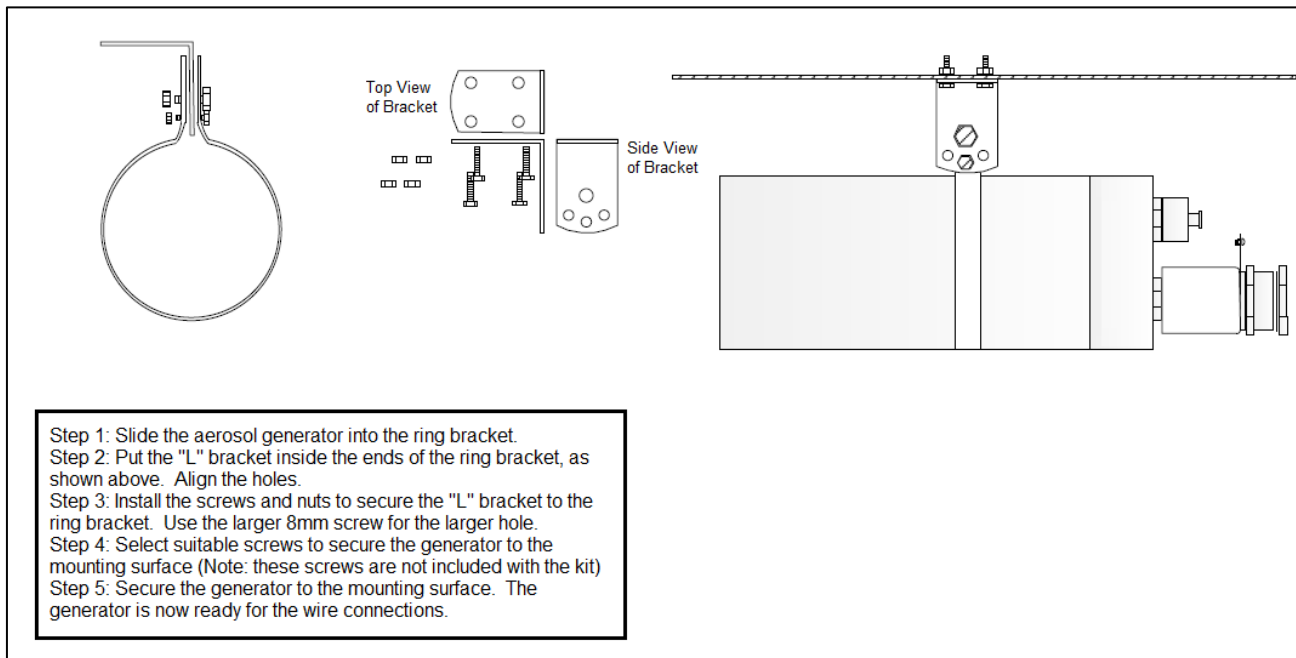

11.2.3 FNX-500S Installation Details

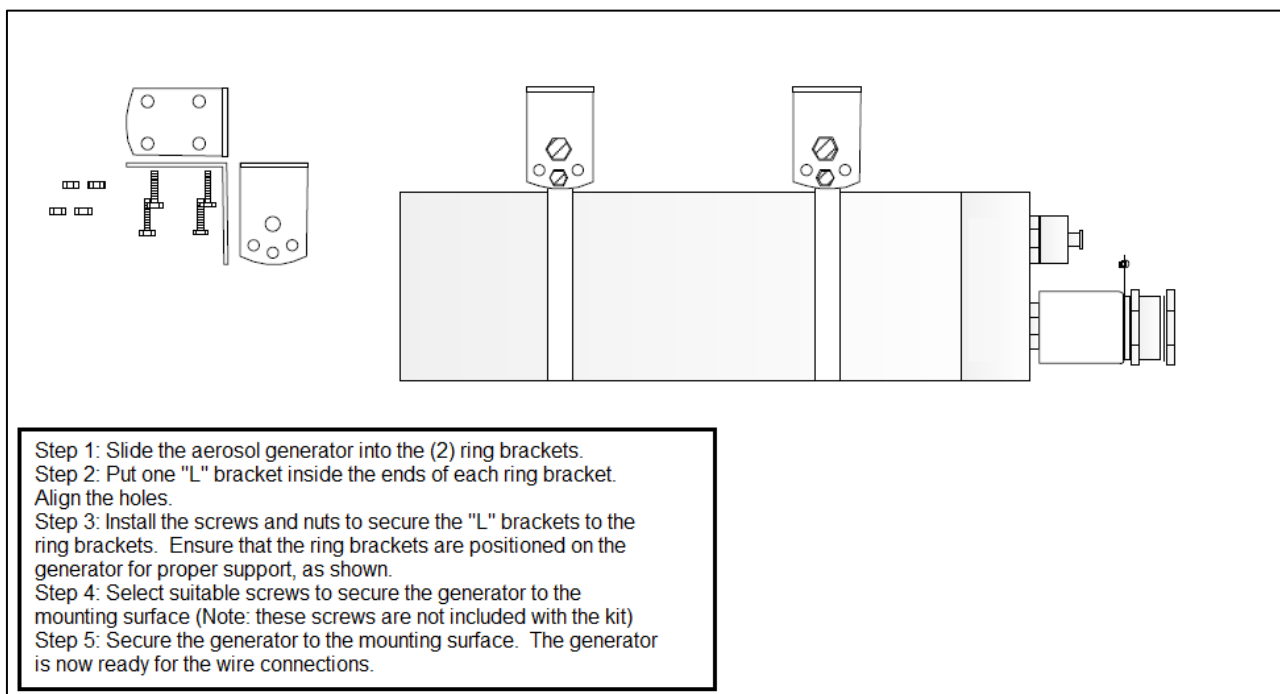

Installation of the FNX-1200 to FNX-5700 generators follows the same basic steps as those shown here. Secure the mounting bracket to the surface, and then attach the generator to the bracket. Always be sure to observe minimum safe distances (see Section 9.1).

11.3 Wiring Connections to the FirePro Xtinguish Aerosol Generators

Follow these steps to connect the generator to the extinguishing circuit:

Step 1: Disassemble the aerosol generator into three parts;

- Part 1 – the cable gland connector
- Part 2 – the activator cable housing
- Part 3 – the generator itself

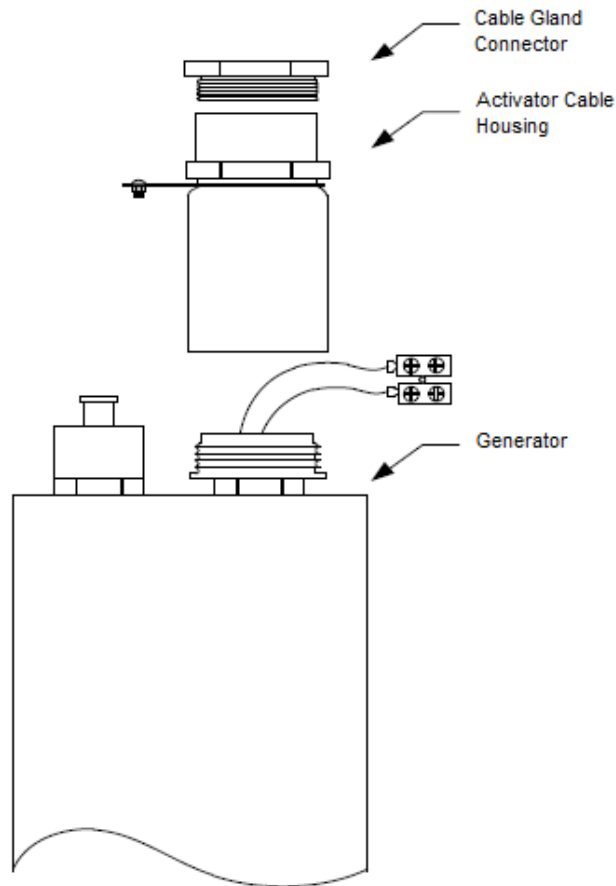

Step 2: Prepare the wires

NOTE: this is important! Be sure to follow the steps below.

- a) Mark the cable 6.5 cm (2.56 inches) from the edge. This is point “A”

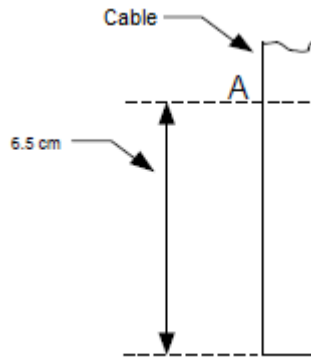

- b) Mark 3 cm (1.18 in.) from point “A” to point “B”. Remove the shield of the cable from point “B” to the edge of the cable.

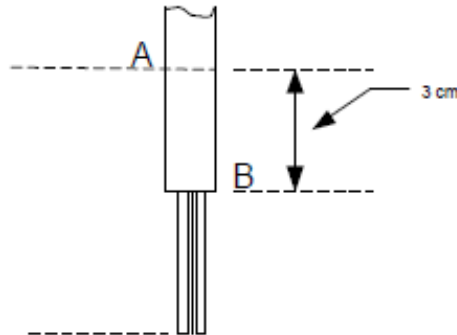

- c) Cut both wires 1.5 cm (0.59 in.) from point “B” to point “C”.

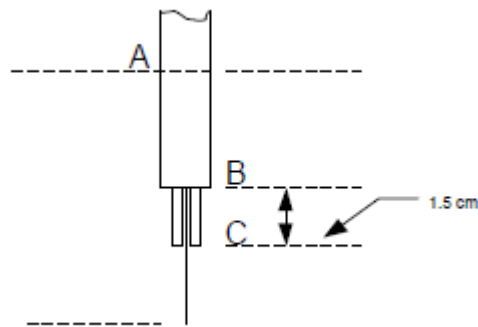

- d) Strip both wires so that approximately 4mm (0.16 in.) of the conductors are exposed. Point "C" to point "D".

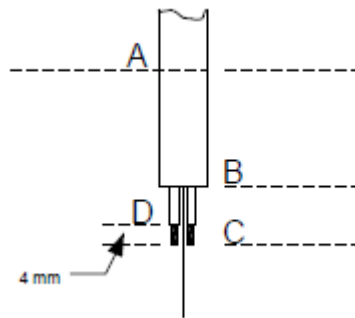

- e) Slice the jacket of the cable from point "B" to point "A" and remove the ground wire. The wire is now prepared for use.

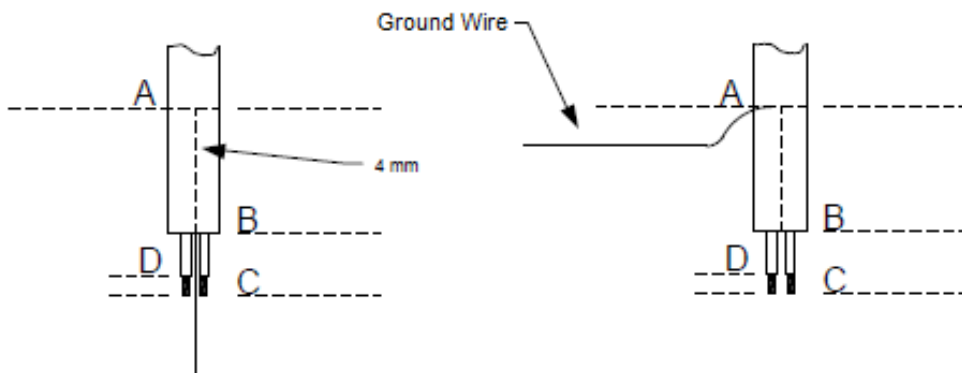

Step 3: Feed the prepared cable through the cable gland connector and the activator cable housing. Do not pass the ground wire through; leave it exposed on the outside of the cable gland connector as illustrated below.

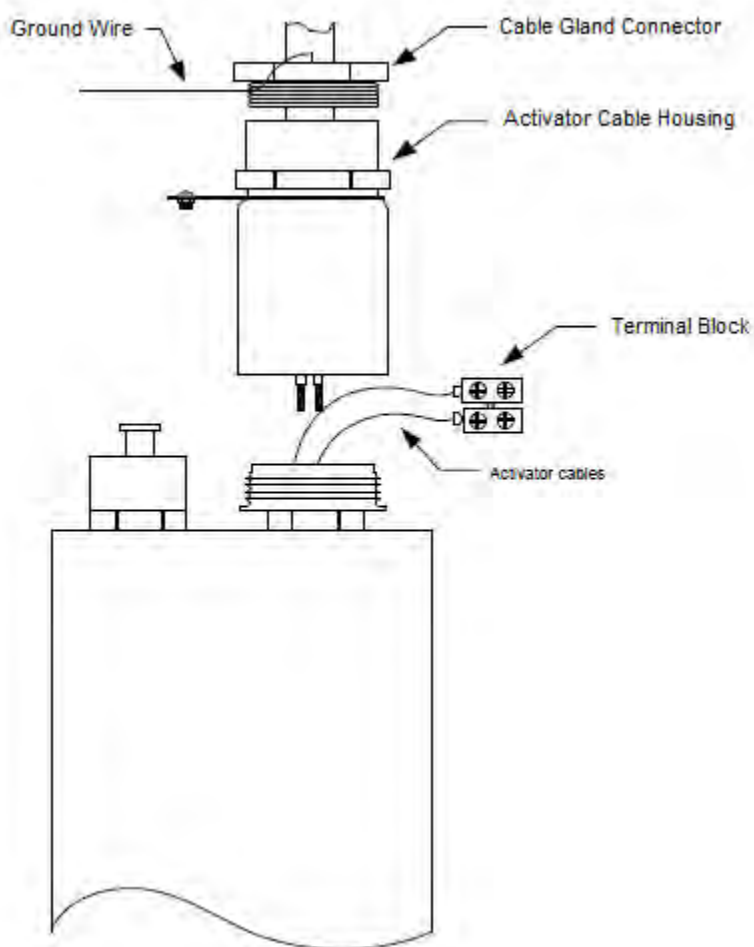

Step 4: Connect the wires to the aerosol generator terminal block. Then pull the cable back until the edge of the cable jacket is showing in the activator housing (see illustration below)

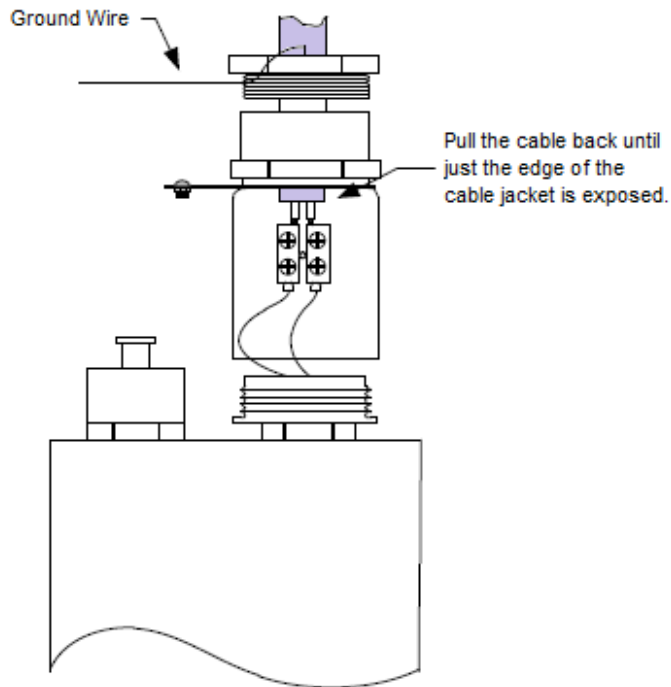

Step 5: While holding the cable in place to prevent it from turning, reattach the activator housing to the generator.

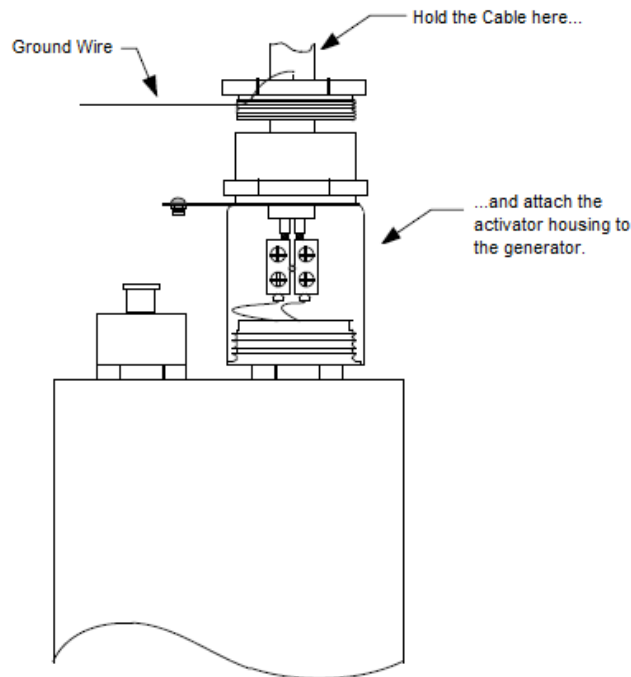

Step 6: Put silicone inside of the cable gland connector in order to seal it.

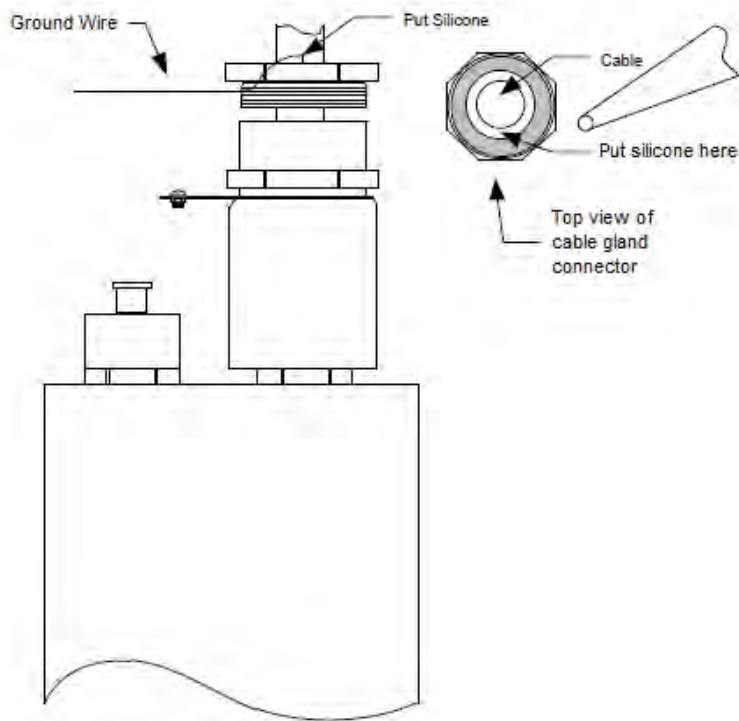

Step 7: Attach the cable gland connector to the activator cable housing. Connect the ground wire to the tab on the activator cable housing.

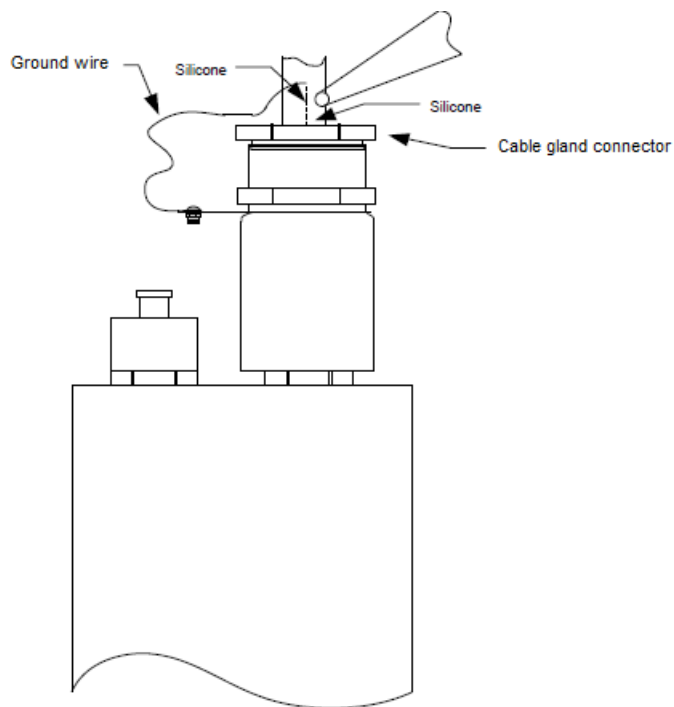

11.4 Condensed Aerosol Generator Height Limitations

The height limitation for each specific condensed aerosol generator is reported on the condensed aerosol generator data sheets (Appendix C).

The “Stream Length” value of each generator should be considered as the maximum height at which it should be installed above the floor or object to protect, whenever the aerosol stream from the generator’s outlet is vertical (at 90 degrees). Whenever a different angle is applied, then the height should be reduced accordingly.

In multiple condensed aerosol generator installations, they shall be distributed throughout the protected enclosure in accordance with the height limitation (coverage) of each condensed aerosol generator.

11.5 Condensed Aerosol Generator Initiation (Activation)

The condensed aerosol generators are initiated (activated) by means of an electric impulse of:

- ▶ 6 - 36 Volts direct-current (DC).

The required current shall be delivered through the connector to the initiator of the condensed aerosol generator.

The condensed aerosol generators are equipped with the Initiator described in Section 7.1.2.

The condensed aerosol generators require a minimum of 0.8 amps of activation current each. Ensure that the necessary power is available to activate the generator(s) during an emergency condition.

11.5.1 Automatic Activation by means of a Fire Detection System

A listed and compatible fire alarm control panel may be used to automatically activate the aerosol generator(s).

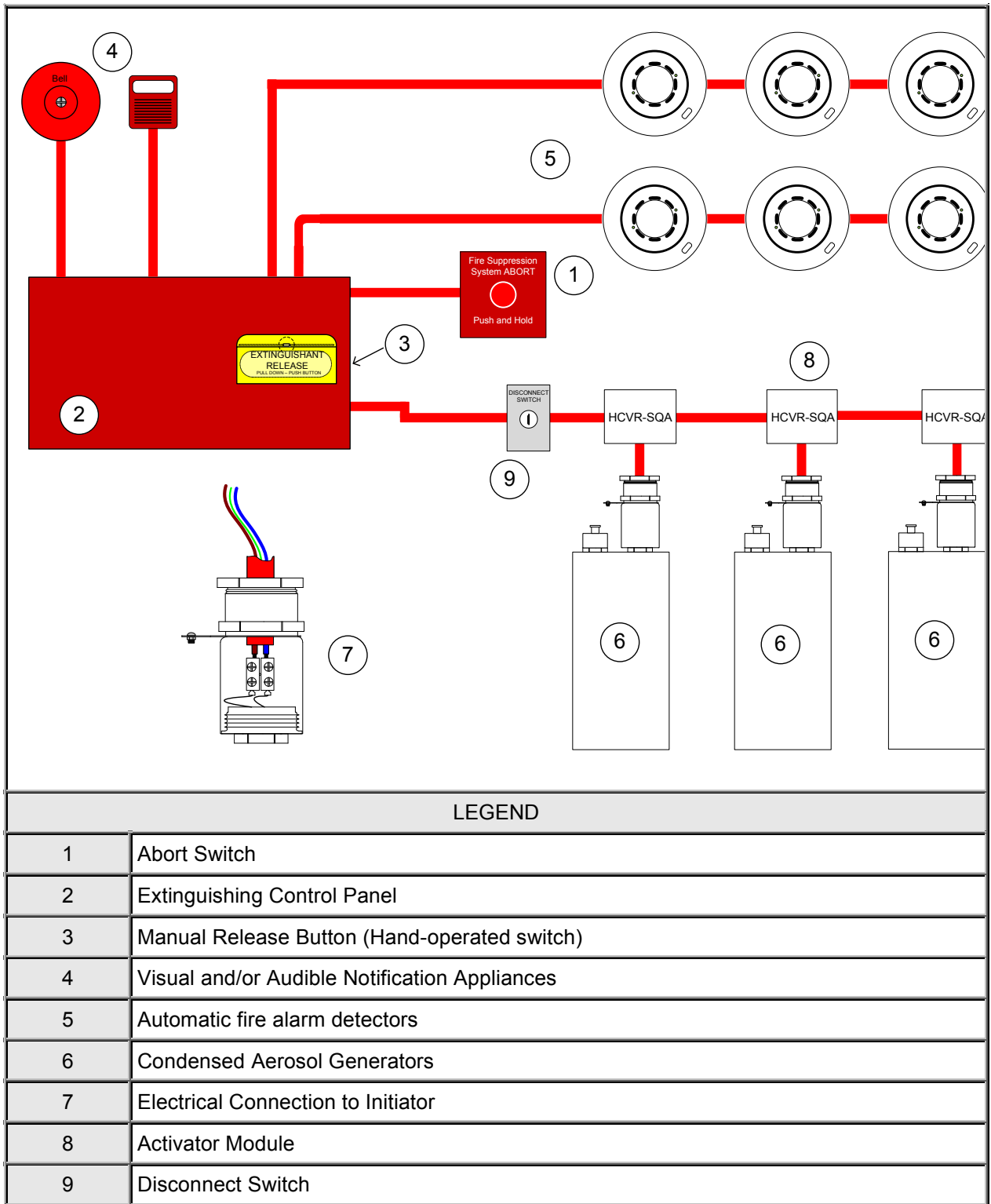

Figure 11.5.1 – Typical System Configuration

12 Hochiki HCVR-3 Releasing Fire Alarm Control Panel

The HCVR-3 is a conventional fire alarm control panel and releasing system. The panel provides connections for initiating device circuits (zones), notification appliance circuits (NACs), releasing circuits, relays outputs, and other circuits.

This manual provides general information about using the HCVR-3 fire alarm control panel with FirePro Xtinguish. For additional details regarding installation, programming and operation of the HCVR-3, please see the *HCVR-3 Installation and Operation Manual*, HA document # HA-06-294.

12.1 System Components

The HCVR-3 system is made up of several components:

- a) The HCVR-3 Fire Alarm Control Panel – the main control panel where all devices terminate, including initiating devices, notification appliances and the releasing circuit. The panel also has a manual release switch which may be used to activate the condensed aerosol generators.
- b) Initiating Devices – typically smoke detectors connected to the zones on the HCVR-3 panel. The HCVR-3 employs a “cross-zone” operation so that at least two zones must be in alarm before the releasing sequence begins. This reduces the possibility of unwanted activation of the aerosol generators.
- c) Notification Appliances – these circuits are provided to notify building occupants of fire alarm events and to indicate the status of the release process. Pre-release notification informs building occupants to leave the protected area immediately, while post-release notification warns to stay out of an area where the extinguishing agent has been discharged.
- d) The HCVR-SQA Sequential Activator Module – this module is used to activate FirePro Xtinguish aerosol generators (g). Up to 20 HCVR-SQA modules may be used, with up to two (2) aerosol generators connected to each HCVR-SQA.
- e) HCVR-AS Abort Switch (optional, as required) – the HCVR-AS Abort Switch may be used to stop the pre-release countdown when it gets to 10 seconds. As long as the button is depressed the countdown timer will remain at 10 seconds, preventing the discharge of the aerosol generator(s). This button may only be operated one time during a countdown sequence; if it is released, the countdown will resume at 10 seconds. See the HCVR-3 manual for more details.
- f) Disconnect Switch – this switch is used to electrically disconnect the aerosol generators from the HCVR-3 fire alarm control panel for testing and maintenance purposes.
- g) The Extinguishing Generator(s) – one or more FirePro Xtinguish condensed aerosol generators used to extinguish a developing fire.
- h) Other Options – these include the HCVR-SDU Status Display Unit and the HCVR-AB Ancillary Board. See the HCVR-3 manual for more details.

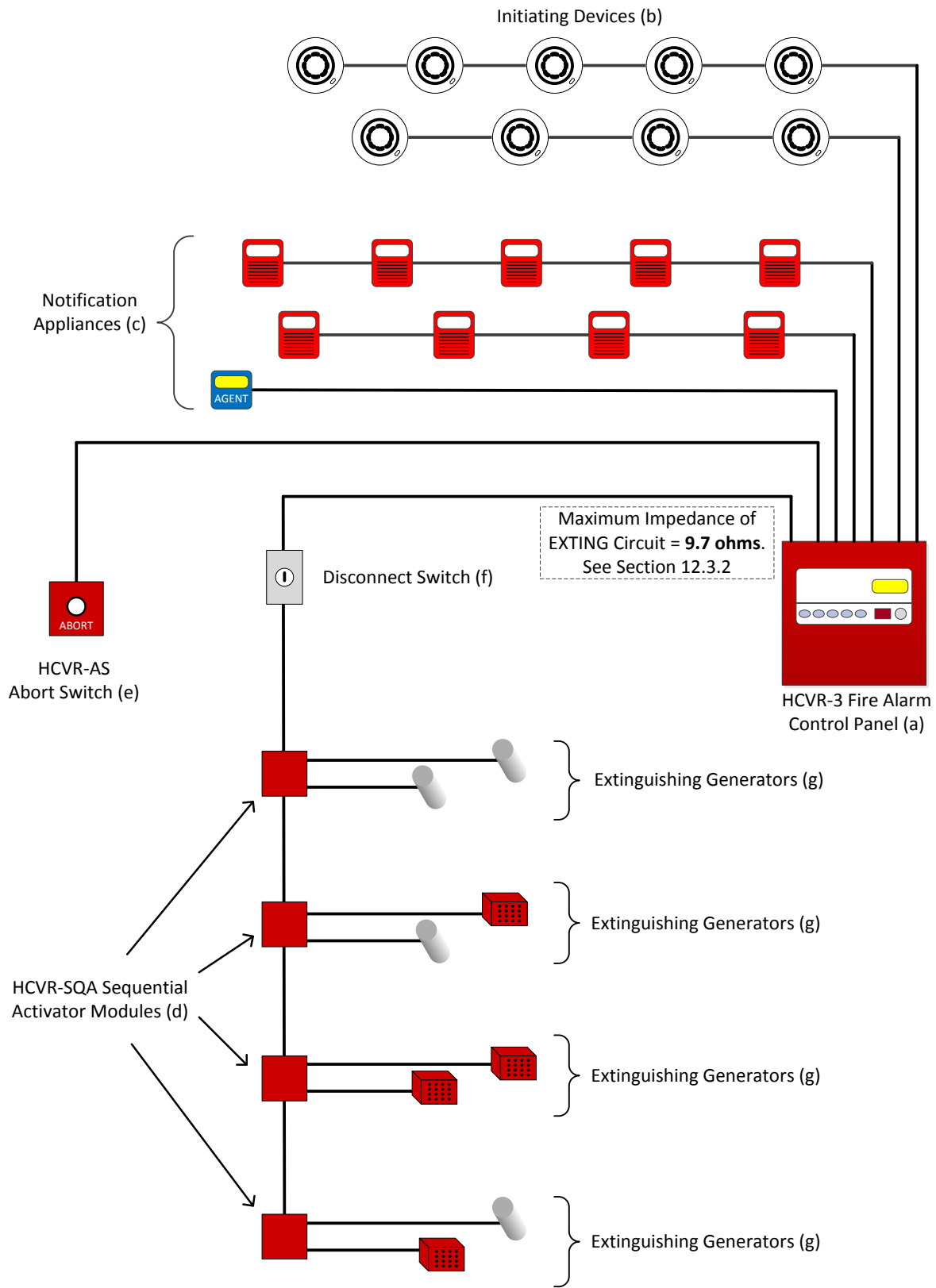

Figure 12.1.1 – System Components

12.2 System Layout

Specifications for total flooding aerosol fire-extinguishing systems shall be prepared under the supervision of a person fully experienced and qualified in the design of such systems and with the advice of the authority having jurisdiction. The specifications shall include all pertinent items necessary for the design of the system, such as the designation of the authority having jurisdiction, variances from the standard to be permitted by the authority having jurisdiction, design criteria, system sequence of operation, the type and extent of the approval testing to be performed after the installation of the system, and owner training requirements.

Install the HCVR-3 control panel, initiating devices, notification appliances, **FirePro Xtinguish** aerosol generators, and all other equipment as stated on the design plans. Always check with the system designer in the event of questions; do not change the mounting location of any device without proper approval.

Ensure that the installation environment is appropriate for the equipment. If the environmental conditions are harsh or unsuitable for the equipment, notify the system designer immediately.

12.3 HCVR-3 Connection Overview

12.3.1 Detection Zones and Notification Appliances

The HCVR-3 fire alarm control panel has three initiating device circuits (zones). Connect smoke detectors and other initiating devices as indicated on the system design plans. Only compatible smoke detectors may be used; see Appendix B of the *HCVR-3 Installation and Operation Manual* for details. Be sure to observe correct polarity.

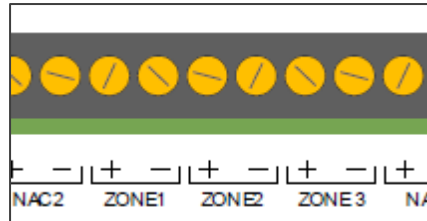

Figure 12.3.1 – Zone Connections

There are three notification appliance circuits (NACs) on the HCVR-3. NACs 1 and 2 are used to signal a general fire alarm condition. NAC 3 is used to indicate one of two things; 1) the system is preparing to activate the aerosol generators to discharge the extinguishing agent, or 2) the aerosol generators have already been activated and the aerosol has been discharged into the compartment. The distinction between these two different events is achieved in the way that the panel operates the output; when the release is imminent NAC 3 provides a pulsing output, but after the aerosol has been discharged the circuit provides a continuous output. Because NAC 3 provides a pulsed output when the panel is counting down prior to activating the aerosol generators, a strobe may not be used on this circuit.

See the *HCVR-3 Installation and Operation Manual* for more information about the zones and NACs on the panel.

12.3.2 HCVR-SQA Sequential Activator

The HCVR-3 fire alarm control panel connects to one or more HCVR-SQA Sequential Activator modules. A maximum of 20 HCVR-SQA modules may be connected to the HCVR-3 panel.

The HCVR-SQA connects to the EXTING circuit on the control panel. The End-of-Line Diode (EOLD) that comes with the HCVR-3 panel must not be used with the HCVR-SQA. In addition, the HCVR-SQA requires 24 volt auxiliary power which is provided by the control panel. See Figure 12.3.2.

As shown in Figure 12.3.2, the last HCVR-SQA module in the circuit must have the termination jumper installed. If only one HCVR-SQA is used, install the jumper on the module. In summary, one HCVR-SQA module shall have the jumper installed and it must always be the last module on the circuit, even if only one module is used.

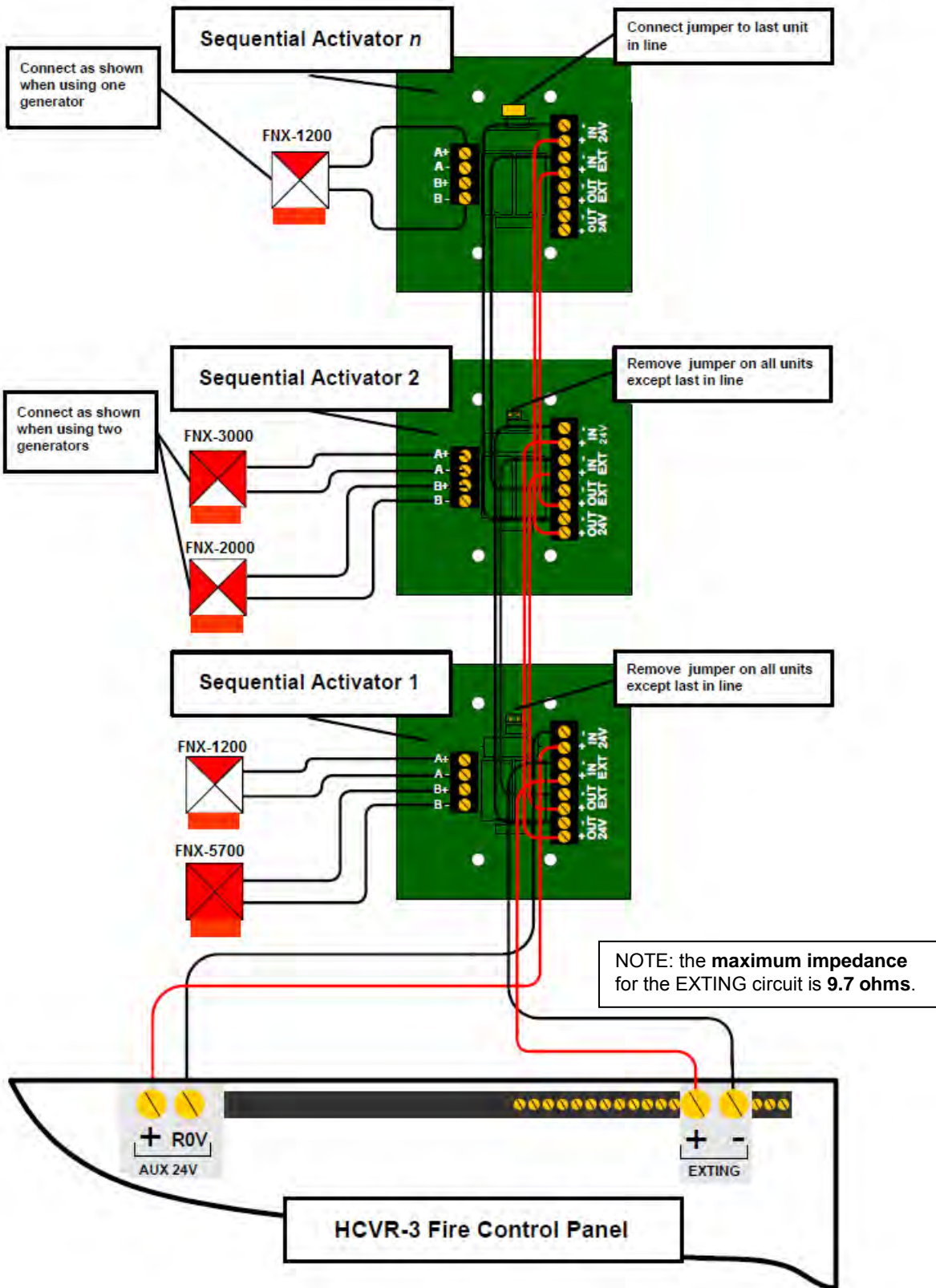

Figure 12.3.2 – Wiring Diagram for the HCVR-SQA

Each HCVR-SQA has two output circuits and will support a maximum of two aerosol generators. Note that if only one generator is used with the HCVR-SQA, the wires are connected to the A+ and B- terminals. If two generators are used, one generator must be connected to the A+ and A- terminals while the other generator is connected to the B+ and B- terminals. Only one aerosol generator may be connected to each output circuit on the HCVR-SQA. DO NOT connect more than one generator to an output circuit!

12.3.2.1 Maximum Wire Length for the EXTING Circuit

Based on information contained in the National Electrical Code (2011 Edition), the following lengths and gauges of wire may be used on the EXTING (Extinguishing) circuit:

- 18 AWG – 380 ft.
- 16 AWG – 606 ft.
- 14 AWG – 960 ft.

Do not use any wire sizes other than those shown above!

These distances are measured from the HCVR-3 control panel to the last generator on the circuit and back to the panel again. For example:

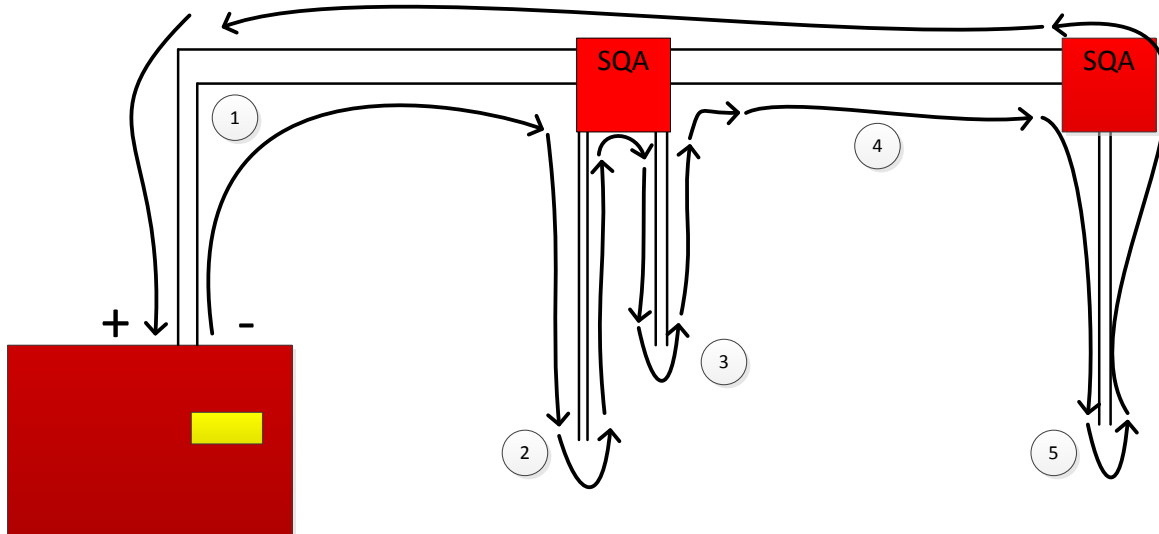

In this example, the first HCVR-SQA Sequential Activator module is installed **50** feet from the HCVR-3 fire alarm control panel. This wire is indicated as section 1 in the illustration. There are two generators connected to the first HCVR-SQA; section 2 (the first generator circuit) has **20** feet of wire, and the second circuit (3) has **15** feet of wire. Section 4 is the wiring between the sequential activator modules and is another **50** feet. Finally, section 5 is for the generator and is **20** feet of wire.

The wire length is added from the EXTING + terminal until it returns to the EXTING – terminal. In this example, there is 310 feet of wire in use - $(50+20+15+50+20)*2 = 310$.

When designing the system, anticipate the size of wire needed for the EXTING circuit by the distance from the panel to the last sequential activator module and the number of generator circuits in use. This will help ensure that the maximum circuit impedance is not exceeded.

Always confirm the maximum impedance of the EXTING circuit by measurement. Before connecting the generators to the sequential activator module circuits, connect the generator circuits at the ends to make a complete circuit. Measure the resistance of the circuit where the wire connects to the HCVR-3 EXTING circuit. Ensure that the resistance is 9.7 ohms or less.

Do not measure the circuit with the generators connected. The generators will introduce additional resistance into the circuit and will affect the accuracy of your measurement.

See the HCVR-SQA Sequential Activator Installation Sheet for additional details.

12.3.3 Disconnect Switch (Hochiki America model HCVR-DS or SOM-R-DS)

To comply with NFPA requirements, a Disconnect Switch (model HCVR-DS or SOM-R-DS) may be installed in the EXTING circuit. The purpose of this switch is to help prevent accidental activation of the aerosol generators during testing and maintenance of the system.

The Disconnect Switch must not be used to Abort an activated release countdown sequence!

Install the Disconnect Switch as indicated on the plans. A single-gang back box (or similar) must be used to securely mount the SOM-R-DS switch. Ensure that all connections are secure and protected. See Figure 12.3.3.

Under normal circumstances the Disconnect Switch is in the *Enable* position. When the switch is moved to the *Disable* position, the HCVR-3 control panel will indicate a trouble. As long as the switch remains in the *Disable* position, the HCVR-3 is disconnected from the sequential activator modules, preventing the panel from activating the aerosol generators. System testing and maintenance may be performed while the Disconnect Switch is in the *Disable* position.

WARNING: ALWAYS ensure that the HCVR-3 panel is in a normal state before returning the Disconnect Switch back to the Enable position! Setting the switch to Enable while the HCVR-3 is in a release state will activate the aerosol generators!

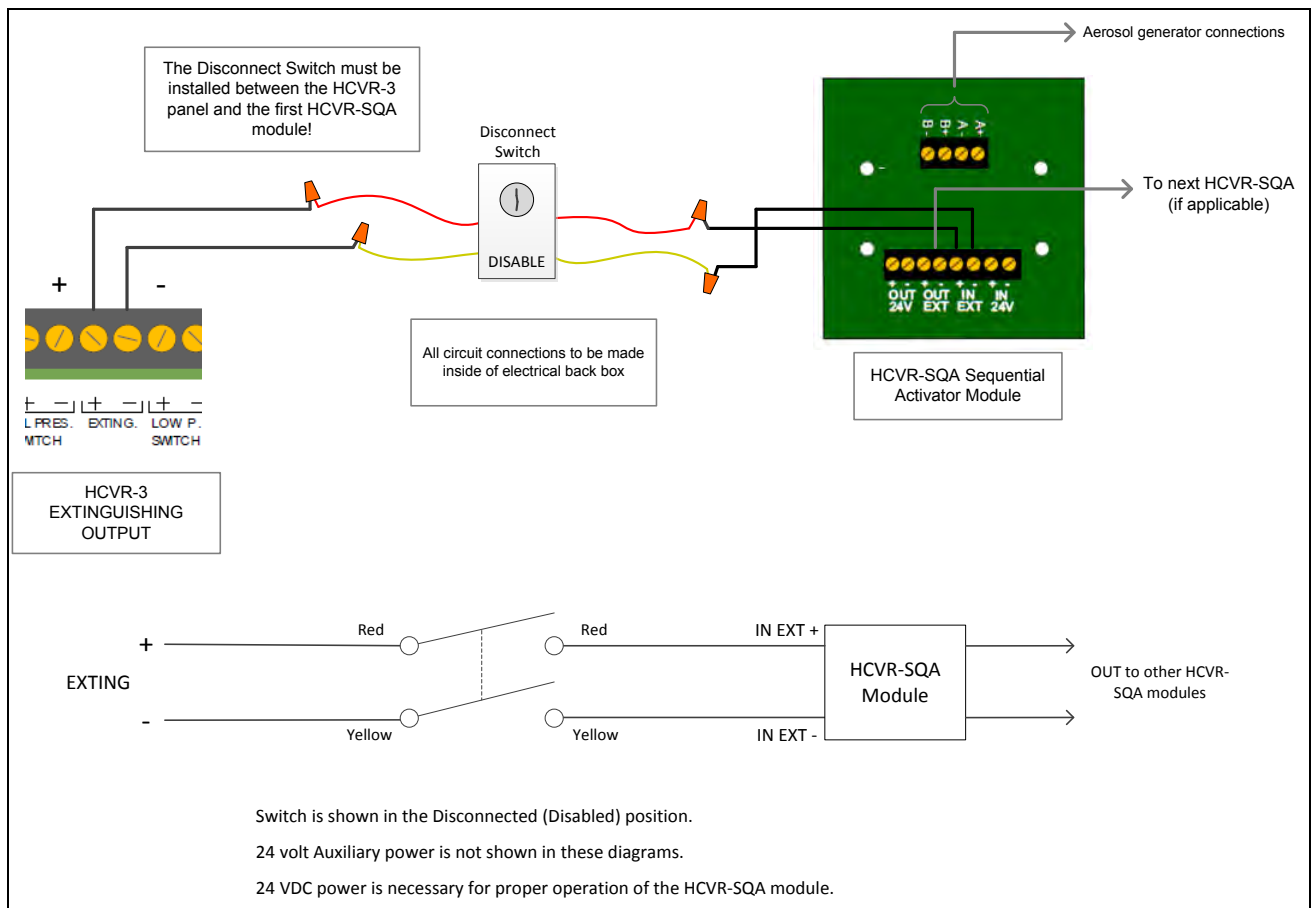

Figure 12.3.3 – Disconnect Switch Diagram and Circuit Wiring

12.4 eLAN RS-H Analog/Addressable Releasing Control Panel

The eLAN RS-H is UL listed as a single-hazard analog/addressable releasing control panel compatible with FirePro Xtinguish.

The eLAN-RS panel contains one SLC loop and may be expanded to include a second SLC loop. Inputs include analog/addressable smoke, heat, and multi-sensors, analog manual fire alarm boxes (pull stations), and a variety of input modules. Supervised and non-supervised output modules allow for flexibility in notification and in interfacing with other systems.

The Sequential Activator Module (FP-SA/GEN3.0) is activated by a SRM, Solenoid Release Module (VF6006-00), or a NAC circuit from the panel. Up to 20 Sequential Activator Modules may be connected to 1 Solenoid Release Module or NAC.

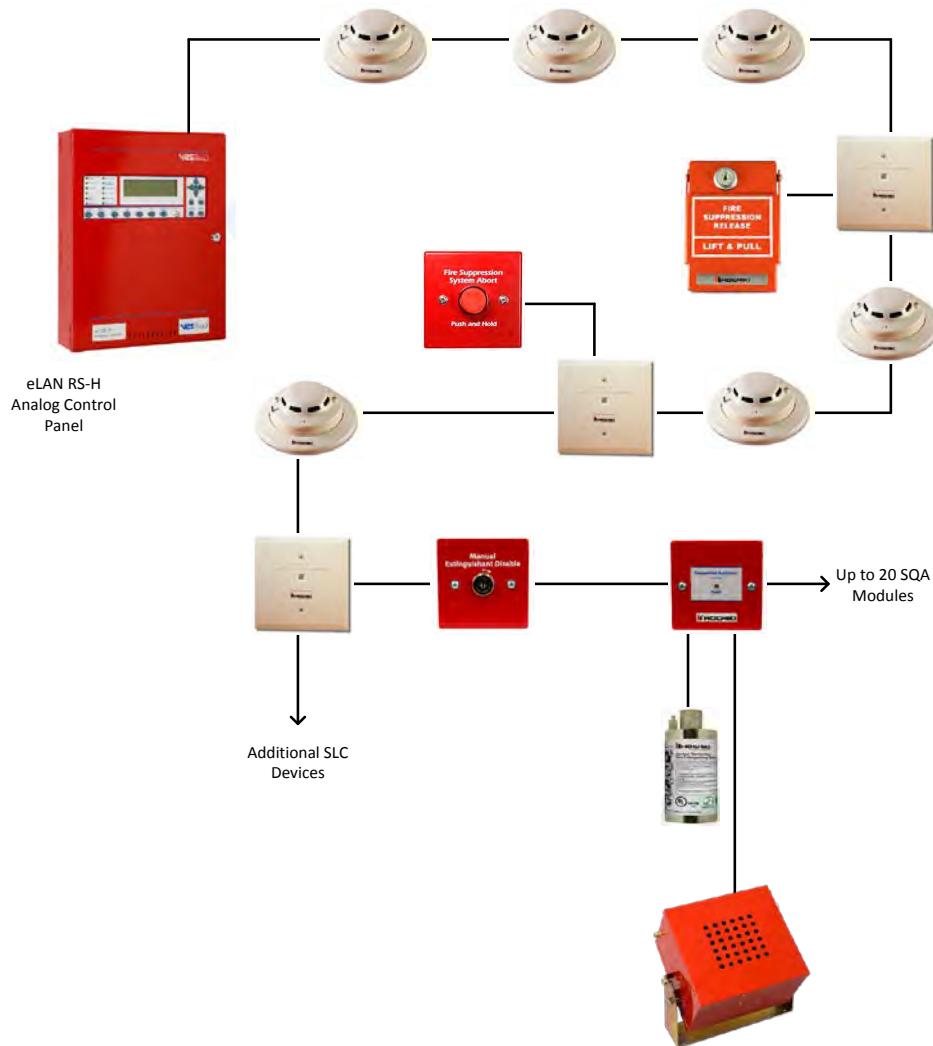

For additional details regarding installation, programming and operation of the eLAN RS-H panel, please see the *eLAN Installation Manual*, document # VF3528-00 (revision E01.13 or higher).

13 Total Flooding System Commissioning

13.1 General

The completed **FirePro Xtinguish** condensed aerosol system shall be reviewed and verified by qualified personnel to meet the approval of the authority having jurisdiction.

All **FirePro Xtinguish** condensed aerosol system components and auxiliary devices used shall be UL-listed. Non-listed equipment shall not be used under any circumstances.

13.2 Installation Acceptance

13.2.1 Basic Checks

- Confirm that the protected enclosure is in conformance with the construction documents.
- The **FirePro Xtinguish** condensed aerosol generators shall be securely fastened to prevent unacceptable vertical or lateral movement during discharge.
- The **FirePro Xtinguish** condensed aerosol generators shall be oriented in such a manner that optimum agent dispersal can be effected.
- The **FirePro Xtinguish** condensed aerosol generator stream shall not directly impinge on areas where personnel may be located.
- The **FirePro Xtinguish** condensed aerosol stream shall not directly impinge on any loose objects or shelves, cabinet tops, or similar surfaces where loose objects could be present and become missiles.
- An adequate number/quantity of **FirePro Xtinguish** condensed aerosol generators to produce the desired specified design application density shall be provided.
- The actual room volumes shall be checked against those indicated on the system drawings to ensure the proper quantity of **FirePro Xtinguish** condensed aerosol agent.
- Fan coast down (inertia) and damper closure time shall be taken into consideration.

13.2.2 Review Enclosure Integrity

All **FirePro Xtinguish** condensed aerosol total flooding systems shall have the enclosure examined and tested to locate and then effectively seal any air leaks that could result in a failure of the enclosure to hold the specified **FirePro Xtinguish** condensed aerosol design application density for the specified holding period.

13.2.3 Review Electrical Components

13.2.3.2 Wiring

All wiring systems shall be installed in compliance with local codes and the system drawings.

Alternating current (ac) and direct current (dc) wiring shall not be combined in a common conduit or raceway.

13.2.3.3 Field Circuits

All field circuits shall be free of ground faults and short circuits.

Where field circuitry is being measured, all devices such as smoke detectors and notification appliances shall be removed and jumpers installed to prevent the possibility of damage within these devices. The devices shall be replaced after measuring.

13.2.3.4 Power Supply

Reliable primary and 24-hour minimum standby sources of energy shall be used to provide for operation of the detection, signaling, control, and actuation requirements of the system.

13.2.3.5 Auxiliary Functions

All auxiliary functions such as a remote annunciator, air-handling shutdown, and power shutdown, shall be checked for operation in accordance with system requirements and design specifications.

If possible, all air-handling and power-cutoff controls shall be of the type that, once interrupted, requires manual restart to restore power.

Silencing of alarms, if desirable, shall not affect other auxiliary functions such as air handling or power cutoff if required in the design specification.

The detection devices shall be checked for proper type and location as specified on the system drawings.

Location:

- ▶ Detectors shall not be located near obstructions or air ventilation and cooling equipment that would appreciably affect their response characteristics.
- ▶ Where applicable, air changes for the protected area shall be taken into consideration.

The detectors shall be installed in a professional manner and in accordance with technical data regarding their installation.

Manual pull stations shall be installed, readily accessible, accurately identified, and protected to prevent damage.

All manual stations used to release agents shall require two separate and distinct actions for operation.

- ▶ All manual stations used to release the **FirePro Xtinguish** condensed aerosol system shall be identified.
- ▶ Particular care shall be taken where manual release devices for more than one **FirePro Xtinguish** condensed aerosol system are in close proximity and could be confused or the wrong system actuated.
- ▶ Manual stations in this instance shall be clearly identified as to which zone or suppression area they affect.

For systems using abort switches, the switches shall be of the dead man type requiring constant manual pressure. The switch shall be installed and readily accessible within the hazard area, and clearly identified.

- ▶ Switches that remain in the abort position when released shall not be used for this purpose.

The control unit shall be installed and readily accessible.

13.2.4 Functional Testing

13.2.4.1 Preliminary Functional Tests

At minimum, the following preliminary functional tests shall be performed:

1. If the system is connected to an alarm monitoring station (Central Station), notify them that the fire system test is to be conducted and that an emergency response by the fire department or alarm station personnel is not desired.
2. Notify all concerned personnel at the facility that a test is to be conducted. Instruct personnel as to the sequence of operation.
3. Disable the **FirePro Xtinguish** condensed aerosol system actuation mechanism so that activation of the release circuit will not actuate the **FirePro Xtinguish** condensed aerosol generators.
4. Check each detector for response.
5. Check that polarity has been observed on all polarized alarm devices and auxiliary relays.
6. Check that all end-of-line resistors have been installed across the detection and notification appliance circuits where required.
7. Check all supervised circuits for trouble response.

13.2.4.2 System Functional Operational Test

The following system functional operational tests shall be performed:

1. Operate detection initiating circuit(s).
2. Verify that all alarm functions and time delays occur according to design specification.
3. Operate the necessary circuit to initiate a second alarm circuit if present.
4. Verify that all second alarm functions occur according to design specifications.
5. Operate manual release.
6. Verify that manual release functions occur according to design specifications.
7. Operate abort switch circuit if supplied.
8. Verify that abort functions occur according to design specifications.
9. Confirm that visual and audible signals are indicated by the control panel.

13.2.4.3 Secondary (Standby) Power Test

The following testing of secondary power shall be performed:

1. Disconnect primary power. Confirm the correct trouble indication.
2. Operate one of each type of input device. Verify that each event is processed properly.
3. Reset the panel after each event.
4. Disconnect a device from each circuit and confirm correct trouble indication.
5. Reconnect primary power supply. Confirm that the panel returns to normal standby condition.

The control panel shall be readily accessible, yet restricted from unauthorized personnel.

*13.2.4.4 Return of **FirePro**[®] Condensed Aerosol System to Operational Condition*

When all testing has been completed, the **FirePro Xtinguish** condensed aerosol generators shall be reconnected so that activation of the release circuit will actuate the **FirePro Xtinguish** condensed aerosol generators, releasing the **FirePro Xtinguish** condensed aerosol agent.

The condensed aerosol system shall be returned to its fully operational design condition.

The central station and all concerned personnel at the end-user's facility shall be notified that the **FirePro Xtinguish** condensed aerosol fire system test is complete and that the system has been returned to full service condition.

13.2.5 System Hand-Over to Client

On system hand-over, ensure that the client has had complete training on the operation of the system. Provide a copy of the FirePro Xtinguish Installation and Operation manual and ensure that they are fully aware of the important considerations concerning system operation and post-discharge responsibilities.

14 Total Flooding Systems Inspection and Maintenance

14.1 Inspection

At least semiannually, a visual inspection shall be conducted to assess the **FirePro Xtinguish** condensed aerosol fire system operational condition. (NFPA 2010 2015 Edition, 9.1.2.1)

14.2 Enclosure Inspection

At least every 12 months, the enclosure protected by the **FirePro Xtinguish** condensed aerosol fire system shall be thoroughly inspected to determine if penetrations or other changes have occurred that could adversely affect agent leakage or change volume of hazard or both.

- ▶ Where the inspection indicates conditions that could result in an inability to maintain the **FirePro Xtinguish** condensed aerosol design application density, these conditions shall be corrected immediately.
- ▶ If uncertainty still exists, the enclosure shall be retested for integrity.

14.3 Maintenance

- ▶ At least annually, all **FirePro Xtinguish** condensed aerosol systems shall be subjected to the manufacturer's test and maintenance procedures by competent personnel.

A periodic inspection of the aerosol fire extinguishers and fire extinguishing systems shall check the following components:

- ▶ Electric wiring
- ▶ Terminals of the electrical ignition
- ▶ Electric contacts (clamped fit?)
- ▶ Mounting bolts (tightened firmly?)
- ▶ The maintenance report with recommendations shall be filed with the owner.
- ▶ Replace generators after 15 years from the date of manufacture (the date of manufacture is indicated on each aerosol generator)

14.4 Penetrations

- ▶ Any penetrations made through the enclosure protected by the **FirePro Xtinguish** condensed aerosol fire system shall be sealed immediately.
- ▶ The method of sealing shall restore the original fire resistance rating of the enclosure.

14.5 Condensed Aerosol Generator Inspection

Inspections to condensed aerosol generators shall be executed by competent personnel only and the results recorded in an inspection report.

A completed copy of the inspection report shall be delivered to the owner of the system or to the Authority Having Jurisdiction (or both, as required); the records shall be retained by the owner/user for the life of the **FirePro Xtinguish** condensed aerosol system.

Where external visual inspection indicates that the **FirePro Xtinguish** condensed aerosol generator casing or the generator itself has been damaged, the unit shall be replaced.

14.6 Training

All persons who could be expected to inspect, test, maintain, or operate the **FirePro Xtinguish** condensed aerosol fire extinguishing system shall be thoroughly trained and kept thoroughly trained in the functions they are expected to perform.

Personnel working in an enclosure protected by a **FirePro Xtinguish** condensed aerosol fire system shall receive training regarding agent safety issues.

14.7 Safety

Safe procedures shall be observed during installation, servicing, maintenance, testing, and managing of the **FirePro Xtinguish** condensed aerosol fire system.

Always observe all local and national inspection and maintenance requirements.

15 Total Flooding System Post-Discharge Intervention

The FirePro Xtinguish aerosol consists of minute solid particles suspended in a gaseous atmosphere (N₂, CO₂, water vapor, and others), thus referred to as 'aerosol'. After discharge the dry particles, which are based on potassium compounds, settle as a fine 'dust' which can easily be removed from the contact surfaces using basic cleaning means.

15.1 Residue Removal

When activated, the solid aerosol forming compound FPC is transformed into a rapidly expanding aerosol, formed by solid particles suspended in a gas phase. The size of such particles is of a few microns; see Section 5.2.

The **FirePro Xtinguish** condensed aerosol composition is of Potassium compounds. It is non-corrosive and is not electrically conductive. It does not cause any damage to sensitive protected equipment and does not react on electronic components, metals, etc.

The solid aerosol forming compound FPC does not contain any Halogen compounds that may react with the flame; thus the condensed aerosol does not produce corrosive halogen-acid by products in its reaction with the flames.

The **FirePro Xtinguish** condensed aerosol solid particles suspended into the aerosol phase are in concentration of a few milligrams per cubic meter. These particles are in an anhydrous phase and will settle at the bottom of the protected enclosure after a period of time as a fine dust. This dust can be easily removed by cleaning, before absorbing humidity.

The **FirePro Xtinguish** condensed aerosol by-products after the extinguishing action consists mainly of KOH in very low concentration (transformed rapidly in K₂CO₃) in an anhydrous phase, as the condensed aerosol particles.

If the aerosol particles are removed by cleaning before they absorb moisture and mix with the combustion residues present in the air after a fire, they will not react with electronic components, metals, etc. Where the particles remain for a lengthy period of time they can absorb moisture and the moisture can react with metal (especially unpainted) so that oxidation could occur.

Important

When extinguishing gases liquefied under pressure are sprayed into a room cooling takes place. In the case of aerosol-forming units the temperature can rise. Both processes affect the humidity. It is therefore important to be aware of the humidity present in the room beforehand. Following a fire and/or activation of the aerosol extinguishing system, the humidity in the room must be reduced as soon as possible.

15.2 Guidelines to Clean the Residue of Condensed Aerosol

- ▶ Clean the residues shortly after discharge (within a few hours maximum)
- ▶ Wipe off dry residues on floor and metal surfaces using a damp cloth or brush
- ▶ Dust away the residues on electrical components using a fan/blower
- ▶ Use special sprays suitable to clean the residues that have settled on electronic components

If the **FirePro Xtinguish** condensed aerosol particles are removed before they can absorb moisture and mix with the combustion residues present in the atmosphere after the fire, they will not react with or affect electronic components, metals, etc.

If the **FirePro Xtinguish** condensed aerosol particles (dust) remain for a longer period, they will absorb moisture. The moisture will react with metals (especially uncoated metals), causing oxidation to occur.

15.3 Pre-Discharge and Post-Discharge Steps

The following steps are necessary prior to discharge of the FirePro Xtinguish aerosol:

- HVAC systems must be shut down. This allows the aerosol to reach the fire as quickly as possible. May be automatically controlled by the fire alarm panel.
- Power must be removed from all equipment, computers, servers, etc. This guarantees that there will be no short-circuit situations following activation. May be automatically controlled by the fire alarm panel.



After the discharge:

- Ventilate the room as soon as possible after discharge (after fire is extinguished and there is no risk of re-ignition). This process will extract much of the discharged aerosol and has the effect of reducing condensation rate and humidity.
- As soon as practically possible, clean equipment using cloths, special moisture removing fluid/sprays, or blower/vacuum as may be necessary, before putting the equipment into operation.

ALWAYS ensure that these steps are followed.

15.4 Additional Information on Cleaning Electronic Components

There are special aerosol sprays that have been specially created to remove dust, condensation, oil, flux, grime, and other particulate matter from delicate electronic circuitry. These sprays work quickly and leave no residue. Examples of such products include:

	Electra XL
	Safety Wash II Aerosol, 4050A
	Maplin N64AN

15.5 Removing the FirePro Xtinguish Condensed Aerosol Generators

When the **FirePro Xtinguish** condensed aerosol generators have to be disconnected and removed, the following steps shall be accomplished:



- Remove power from the fire detection system and ensure that it cannot be switched on;



- Disconnect the power wires from the **FirePro Xtinguish** condensed aerosol generators and ensure that they cannot be connected;



- Ensure that you are standing firmly and comply with the rules for working at height (Working Conditions Act);



- Remove the **FirePro Xtinguish** condensed aerosol generators by unscrewing the bolts and nuts holding them;



- Carefully remove the **FirePro Xtinguish** condensed aerosol generator from the brackets and place it on a stable surface;



- After removing the **FirePro Xtinguish** condensed aerosol generators, put the fire detection and alarm installation back into operation in accordance with the guidance of the Authority Having Jurisdiction.



- If the **FirePro Xtinguish** condensed aerosol generators have been activated and are still warm, wear heat-resistant gloves.

15.6 Waste and Environment

After activation the **FirePro Xtinguish** condensed aerosol generators may be disposed of as normal waste after dismantling.

If a condensed aerosol generator has been removed from service *but it has not been activated and it still contains the solid aerosol-forming compound FPC*, the generator must be returned to Hochiki America Corporation for proper disposal.

16 Appendix A – Material Safety Data Sheets (MSDS)

Hochiki America Corporation

Issue date: 09.05.2012

1. Identification of the Substance/Company					
1.1	Trade name	: FirePro Xtinguish			
1.2	Manufacturer/Supplier	: Hochiki America Corporation Phone : (714)-522-2246 Fax : (714)-522-2268 e-mail : technicalsupport@hochiki.com website : www.hochiki.com			
1.3	Telephone number in case of emergency: (714)-522-2246				
2. Composition/Information on Ingredients					
2.1	Component	Wt. %	CAS No.	EINECS	Class, R and S phrases
	Potassium Nitrate	77	7757-79-1	231-818-8	See section 15
	Potassium Carbonate	4	584-08-7	209-529-3	See section 15
	Magnesium	<1	7439-95-4	231-104-6	See section 15
	Epoxy Resin Polymer	18	25068-38-6	any "polimerizate, polycondensate, or polyadduct" is exempted by 81/437/EEG	See section 15
3. Hazards Identification					
3.	<ul style="list-style-type: none"> - Hazards for humans related to the FPC solid compound has not been found. - Hazards for humans related to the aerosol released by the solid compound have not been established because TLV's are not applicable. - Signs and symptoms related to the aerosol phase are only referred to acute exposure and/or chronic overexposures, while in real life the exposure will be very short (i.e. in the event of an accidental discharge when people were not evacuated on time). 				
	For humans				
3.1	Threshold Limit Values	: None established			
	Signs and Symptoms by acute exposure				
	Eye Contact	: At normal contact no injury			
	Inhalation	: Not a likely route of entry			
	Skin Contact	: At normal contact no injury			
	Ingestion	: At normal contact no injury			
	Chronic Overexposure	: At normal contact no injury			
Medical Conditions Generally Aggravated by Exposure	: None known				
For Environment	: None established				
4. First-Aid Measures					
4.	First-Aid measures are referred to acute exposure and/or chronic over exposure				
4.1	Inhalation	: Remove from exposure area to fresh air.			
	Eye Contact	: If necessary wash eyes.			
	Skin Contact	: Change clothing and shoes. Wash skin with soap.			
	Ingestion	: Not likely.			

5.	Firefighting Measures	
5.1	Extinguishing Media	: This is an Extinguishing Agent
5.2	Unusual Fire and Explosion Hazards	: The material does not present an explosion danger. It can be ignited by means of a fire. Hot aerosol is present in the close up area of the outlets
5.3	Special Procedures	: In places where there is a fire always wear personal protecting equipment and clothing

6.	Accidental Release Measures	
6.1	Personal Precautions	
	Respiratory Protection	: at normal contact not needed
	Hand Protection	: at normal contact not needed
	Eye Protection	: at normal contact not needed
6.2	Environmental Precautions	
	Waste Disposal Methods	: See section 13
6.3	Clean up Precautions	: Sweep up

7.	Handling and storage	
7.1	Handling Precautions	: Avoid contact with combustible materials.
7.2	Storage Precautions	: Should be stored in original container. Keep dry.
	Storage Class	: 9 miscellaneous , solid

8.	Exposure Controls and Personal Protection	
8.1	Exposure	: Before entering a room with the material in aerosol phase vent properly to avoid unnecessary exposure.
8.2	Personal protection	
	Respiratory Protection	: at normal contact not needed
	Hand Protection	: at normal contact not needed
	Eye Protection	: at normal contact not needed
	Skin and Body Protection	: at normal contact not needed

9.	Physical and Chemical Characteristics	
.1	Appearance	: Solid
	Color	: Off white
	Odor	: None
	Relative Density	: Not applicable
	Solubility in water	: Insoluble
	Ph (if in water, % Conc.)	: Not determined
	Boiling Point	: Not applicable
	Vapor Pressure (mm Hg)	: Not applicable
	Vapor Density	: Not applicable
	Flash Point	: Not applicable
	Flammability Limits in Air (% by volume)	: Not applicable
	Auto Flammability	: Not applicable
	Explosive Properties	: Not applicable
	Oxidizing Properties	: Not determined

10.	Stability and Reactivity	
10.1	Stability	: Stable
	Conditions to avoid	: None known
10.2	Hazardous Reactions	: Will not occur
	Conditions to avoid	: None known
10.3	Materials to Avoid	: None known
10.4	Hazardous Decompositions Products	: None ascertained

11. Toxicological Information		
11.	The TLV's (Threshold Limit Values) of the chemicals released in the aerosol phase are applicable only in case of long, as long as a complete professional life, exposure. This is not the case of a real life situation.	
11.1	Product	
	The potential damage is not caused by the product mixture composition, but by the fact that it is respirable. The TLV's apply in case of long exposure, sometimes exposure during a complete professional life, whilst in this case is once only and short (in case of accidental discharge when evacuation does not take place on time).	
In case of fire the toxicity is caused by the fire itself and the products involved in the fire.		
11.2	Components	
	Potassium Nitrate	Toxicity : Oral LD ₅₀ (rat) 3750 mg/Kg Target Organs : Blood, central nervous system
	Potassium Carbonate	Toxicity : Oral LD ₅₀ (rat) 1870 mg/Kg / Oral LD ₅₀ (mouse) 2570 mg/Kg Target Organs : Respiratory system
	Magnesium	Toxicity : Oral LD ₅₀ (dog) 230 mg/Kg Target Organs : Central nervous system, liver, kidneys
	Epoxy Resin Polymer	Toxicity : Oral LD ₅₀ (rat) 11.4 g/Kg Irritation Data : Skin (guinea pig) 2750 mg/55 days Inert Eye (rabbit) 100 mg Mild
12. Ecological Information		
12.1	Mobility Absorption/Desorption	: with present data no problems : with present data no problems
12.2	Degradability Biotic and Abiotic Degradation Aerobic and Anaerobic Degradation Persistence	: with present data no problems : with present data no problems : with present data no problems : with present data no problems
12.3	Accumulation Bioaccumulation Potential Biomagnification	: with present data no problems : with present data no problems : with present data no problems
12.3	Short and Long Term Effects on	
	Ecotoxicity	: with present data no problems
	Aquatic Organisms	: with present data no problems
	Soil Organisms Plants and Terrestrial animals	: with present data no problems : with present data no problems
12.4	Other Adverse Effects	
	Ozone Depleting Potential (ODP)	: none
	Photochemical Ozone Creation Potential	: none
	Global Warming Potentials (GWP) Effects on Waste Water Treatment Plants	: none : none : with present data no problems
13. Disposal Considerations		
13.1	Dispose of in Compliance with local, state and national regulations.	
14. Transportation Information		
14.1	Hazard Class or Division	: 9 miscellaneous, solid : For additional transport information contact Hochiki America Corporation

15. Regulatory Information			
15. For 15.1 Components: The EU classification and R&S phrases, referred to the components of the FPC compound are related only to the single components considered as separate chemical entities. Once mixed in the production of the FPC compound, the risk sentences of the single components are not applicable being the FPC compound a separate chemical entity.			
Product			
Potassium Nitrate	EU Classification R Phrases S Phrases	Oxidizer 8 16 41	- Contact with combustible material may cause fire Keep away from sources of ignition – No smoking In case of fire and/or explosion, do not breathe fumes
Potassium Carbonate	EU Classification R Phrases S Phrases	Irritant 22 36/37/38 26 37/39	- Harmful if swallowed Irritating to eyes, respiratory system and skin In case of contact with eyes, rinse immediately with plenty of water and seek medical advice Wear suitable gloves and eye/face protection
15.1 Magnesium	EU Classification R Phrases S Phrases	Flammable 15 17 2 43 7/8	- Contact with water liberates highly flammable gases Spontaneously flammable in air Keep out of reach of children In case of fire never use water Keep container tightly closed and dry
Epoxy Resin Polymer	EU Classification R Phrases S Phrases	Irritant 36/38 43 53 28 37/39 61	- Irritating to eyes and skin May cause sensitisation by skin contact May cause long-term adverse effects in the aquatic environment In case of contact with skin, rinse with water Wear suitable gloves and eye/face protection Avoid release to the environment. Refer to special instructions/ Safety Data Sheets
Limit Values for Exposure	: None listed		
EINECS Status	: All components are included in EINECS inventories		
Restrictions on Marketing and Use	: None (Refer to any other national measures that may be relevant)		

16. Other Information	
16.1	None Known

17. Disclaimer	
17.1	The data in the above material safety data sheet reflect the current state of knowledge of our product and shall be used only as a guideline. No binding statements as to the contractually agreed product characteristics may be inferred there from.

17 Appendix B – FirePro Xtinguish Aerosol Generators



FNX-20S / FNX-20T



FNX-40S / FNX-40T



FNX-80S / FNX-80T



FNX-100S



FNX-200S



FNX-500S

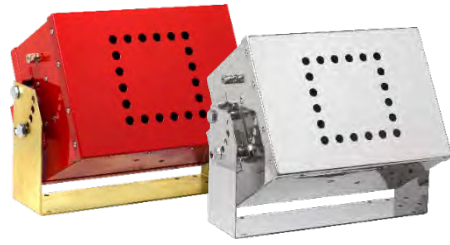

**FNX-1200
FNX-1200T
FNX-1200S
FNX-1200TS**



**FNX-2000
FNX-2000T
FNX-2000S
FNX-2000TS**



**FNX-3000
FNX-3000T
FNX-3000S
FNX-3000TS**

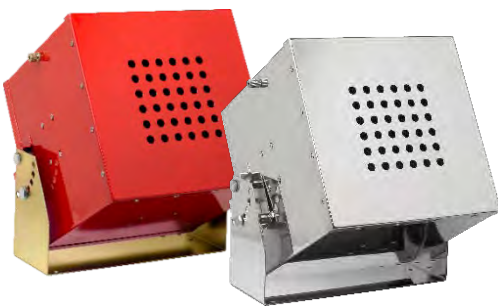

**FNX-4200T
FNX-4200TS**

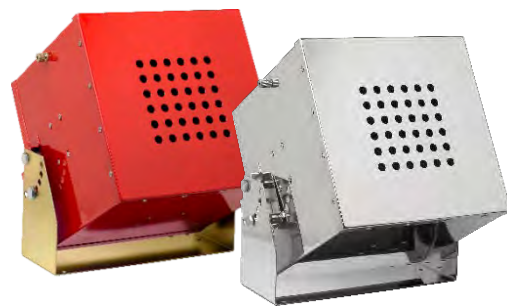

**FNX-5700
FNX-5700T
FNX-5700S
FNX-5700TS**





18 Appendix C – FirePro Xtinguish Generator Datasheets











FirePro. Xtinguish - Condensed Aerosol Generator Technical Information Summary

Model	Weight (g)		Dimensions (mm)			Minimum Distances (m / ft.)		Aerosol Discharge Time (s)		Stream Length (m / ft.)	Number of Discharge Outlets
	Gross	Net	Height	Diameter		Combustible Materials (T2)	Personnel (T3)	Min	Max		
			Height	Width	Length						
FNX-20S	310	20	165	32		0.1 / 0.33	0	3	6	1 / 3.28	2
FNX-20T	310	20	165	32		0	0	3	6	1 / 3.28	1
FNX-40S	610	40	140	51		0.1 / 0.33	0	5	10	1 / 3.28	2
FNX-40T	615	40	140	51		0	0	5	10	1 / 3.28	1
FNX-80S	870	80	185	51		0.1 / 0.33	0	5	10	2 / 6.56	2
FNX-80T	840	80	185	51		0	0	5	10	2 / 6.56	1
FNX-100S	1370	100	155	84		0	0.2 / 0.66	5	10	1 / 3.28	1
FNX-200S	1840	200	185	84		0	0.3 / 0.99	5	10	2 / 6.56	1
FNX-500S	3340	500	260	84		0.1 / 0.33	0.5 / 1.64	5	10	2 / 6.56	1
FNX-1200/S/T/TS	10900	1200	167	216	300	0	1.5 / 4.92	15	20	3.5 / 11.49	1
FNX-2000/S/T/TS	15500	2000	185	300	300	0	1.5 / 4.92	15	20	3.5 / 11.49	1
FNX-3000/S/T/TS	16300	3000	185	300	300	0.6 / 1.97	2.0 / 6.56	15	20	3.5 / 11.49	1
FNX-4200T/TS	23600	4200	300	300	300	0.99 / 3.25	2.3 / 7.55	15	20	5.0 / 16.4	1
FNX-5700/S/T/TS	26400	5700	300	300	300	0.6 / 1.97	2.0 / 6.56	15	20	8.4 / 27.55	1

Notes and Legend

Symbol	Description
T2	Aerosol stream temperature from generator discharge outlet equal to or less than 200°C
T3	Aerosol stream temperature from generator discharge outlet equal to or less than 75°C
Note:	In case of generator actuation failure, the solid compound will automatically start the aerosol forming reaction when the temperature reaches 300°C.
Model variations	The generators have S, T, and TS variants. "S" has a stainless steel housing rather than the red steel housing. The "T" type can be activated by BTA and electrically. The "TS" type combines BTA + electrical activation and stainless steel housing.

Activation Mode		Max volume protected	
	Electrical activation		Max volume protected for Class "A" Fire
			Max volume protected for Class "B" Fire
			Max volume protected for Class "C" Fire

Classification of fires			
Europe: CEN Standard EN2 * International: ISO Standard 3941		NFPA 10	
Following the EN 2 Classification of Fire the fire classification identify the combustible material originating the fire:		Following the NFPA 10 Standard for portable fire extinguisher the fire classification identify the combustible material originating the fire:	
	CLASS "A" Fire involving solid materials, usually of an organic nature (such as paper, wood, plastics and so on), in which combustion normally takes place with the formation of glowing embers.	Fire in ordinary combustible materials such as wood, cloth, paper, rubber and many plastics.	CLASS "A" 
	CLASS "B" Fires involving flammable liquids or liquefiable solids such as paraffin, petrol, oil and so on	Fires in flammable liquids, oil, greases, tars, oil base paints, lacquers and flammable gases.	CLASS "B" 
	CLASS "C" Fire involving flammable gases such as propane, butane, methane and so on.		CLASS "C" 
	CLASS "D" (1) Fire involving metals such as aluminium, magnesium, titanium and so on.	Fires in combustible metals such as magnesium, titanium, zirconium, sodium, lithium and potassium.	CLASS "D" (1) 
E	CLASS "E" (2) Fires involving electrical apparatus	Fire which involve energized electrical, non-conductivity of the extinguishing medium is of importance. (When electrical equipment is de-energized, extinguishers for Class "A" or "B" fires may be used safely).	CLASS "C" 
	CLASS "F" Fire involving cooking oils and fat and such like.	Fire involving cooking grease, fats and oils.	CLASS "K" (3) K
Note:	(*) Comite Europeen de Normalisation (CEN standard EN2) closely follows ISO standard 3941 (1) is not suitable to extinguish Class D fires (see technical manual) (2) Code of practice definition, not included inside EN2 (3) Not tested to Class K fires		

FirePro Xtinguish - Height of Installation and Minimum Clearances

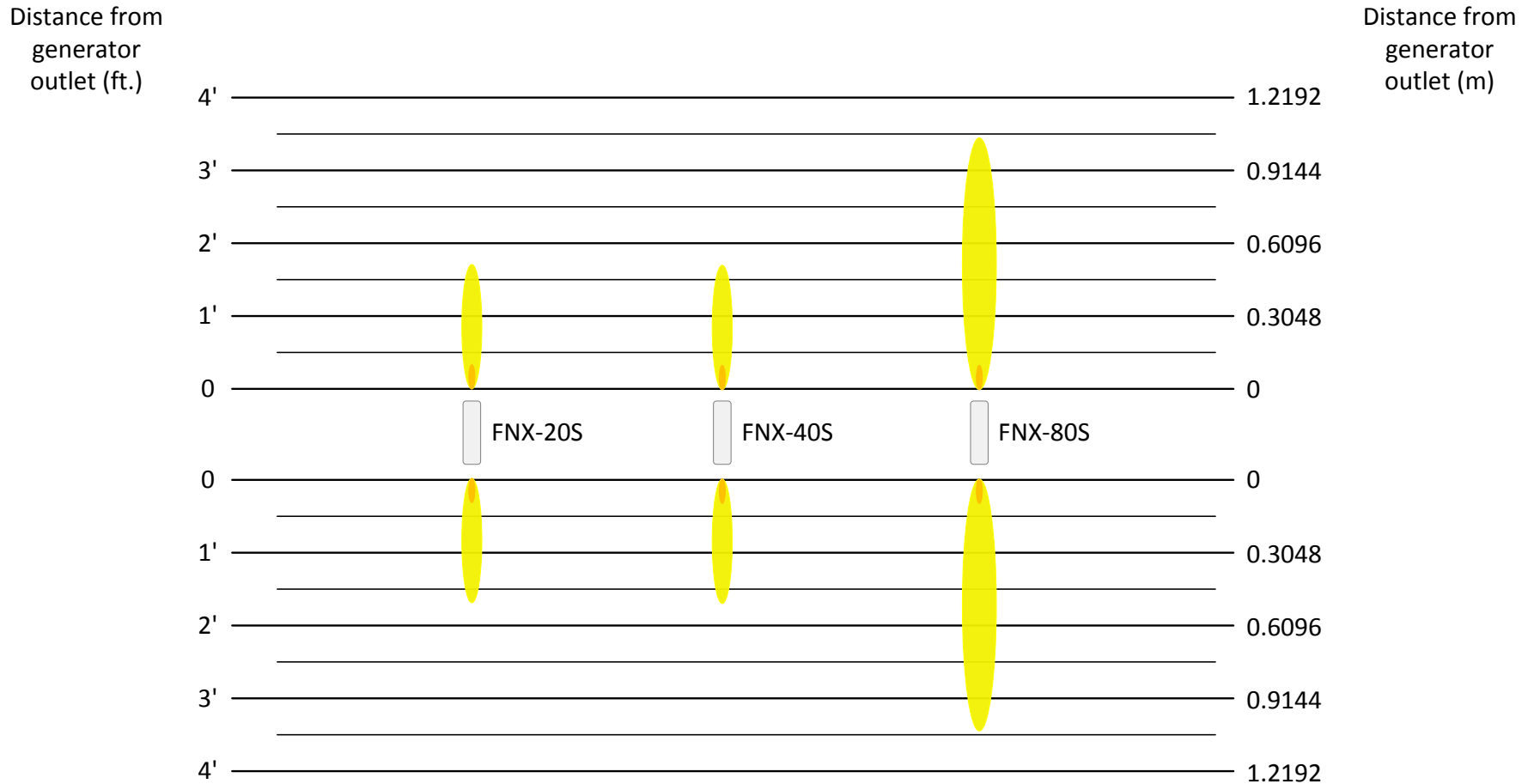





- Min. Distance to Combustibles
- Min. Distance to Personnel
- Stream Length

0'-0"	
0'-4"	0.1m
3'-3.37"	1.0m

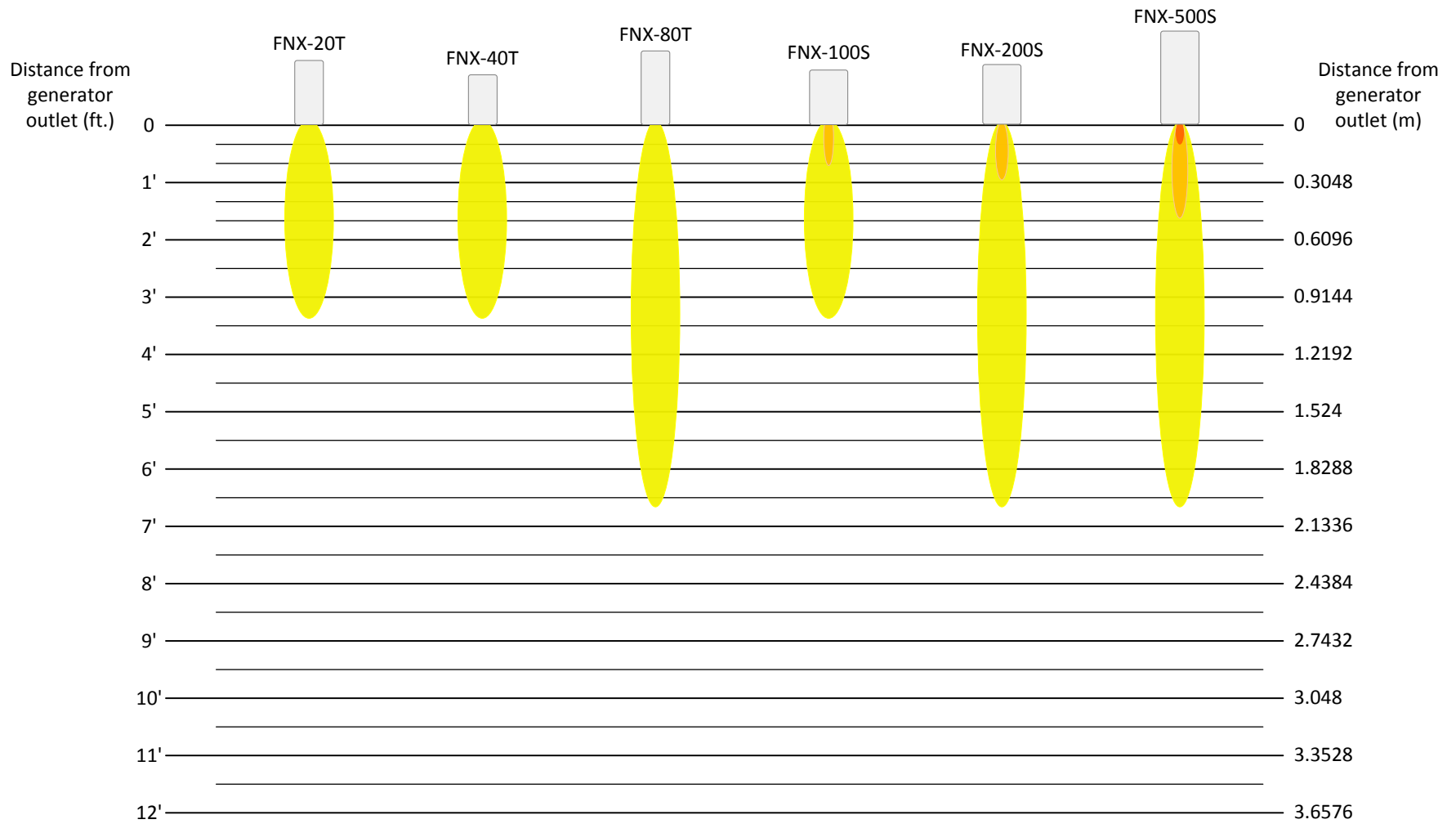
0'-0"	
0'-4"	0.1m
3'-3.37"	1.0m

0'-0"	
0'-4"	0.1m
6'-6.740"	2.0m



	Min. Distance to Combustibles	0'-0"	0'-0"	0'-0"	0'-0"	0'-0"	0'-3.937"	0.1m
	Min. Distance to Personnel	0'-0"	0'-0"	0'-0"	0'-7.874"	0.2m	0'-11.81"	0.3m
	Stream Length	3'-3.37"	3'-3.37"	6'-6.740"	3'-3.37"	1m	6'-6.740"	2m

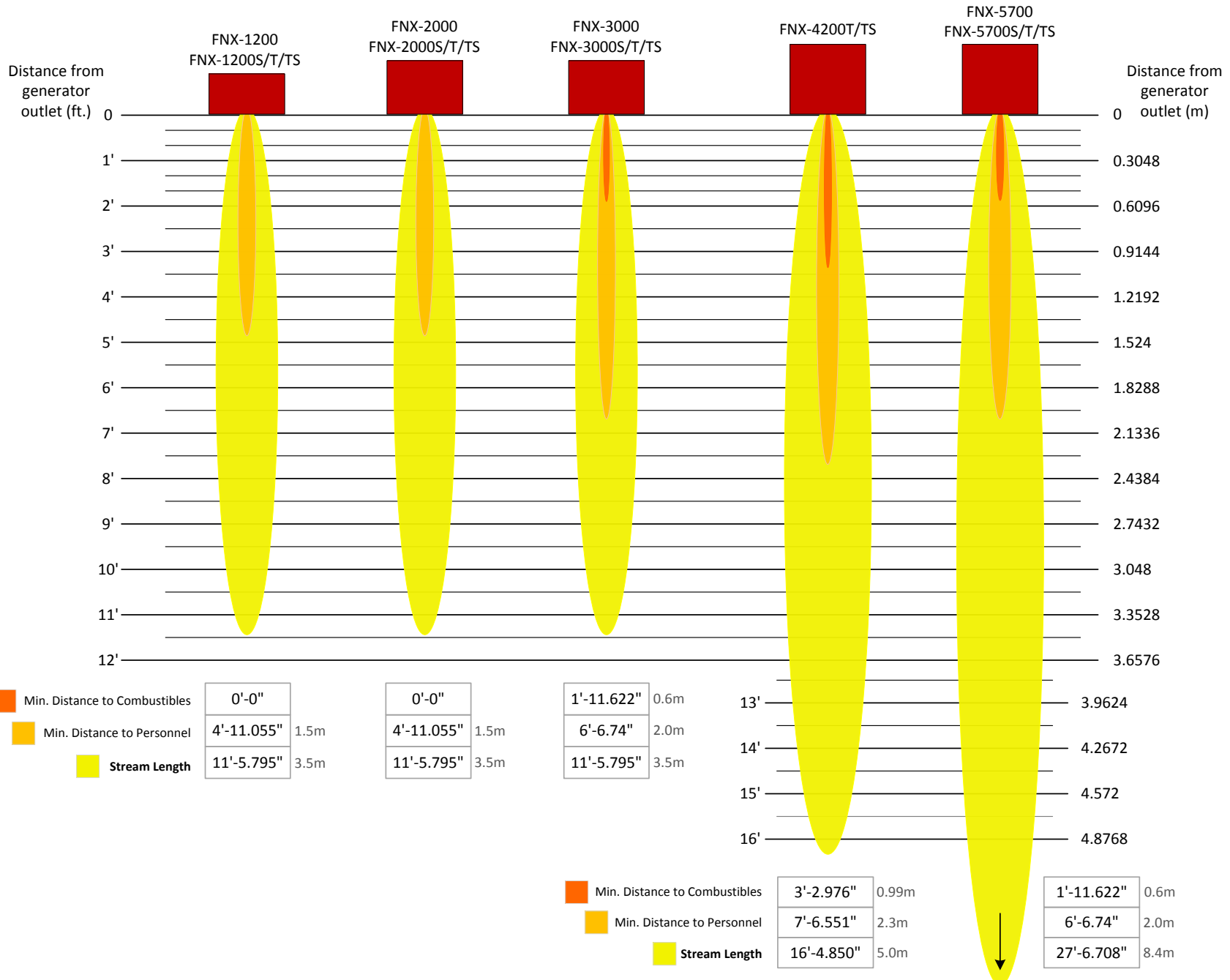

FirePro Xtinguish Condensed Aerosol generators: FNX-20S

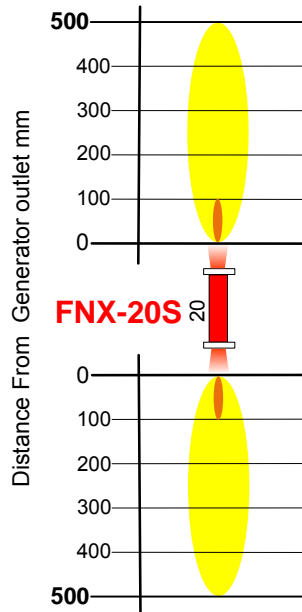

LEGEND

- Maximum height of installation
- Minimum clearance from persons
- Minimum clearance from combustible materials

Technical Data

Mass of FPC (Aerosol Generating Solid Compound)	20 g				
Generator gross weight	Weight		Tolerance		
	310 g		± 5%		
Activation mode	Electrical				
Value of activation	6/12/24/36 V D/C 0.8 A 3-4 s				
FPC activation device	Heating elements with 1.6-3.6 Ω Resistance				
Activation line supervision current (Max)	5 mA				
Aerosol discharge time	Min.		Max		
	3 seconds		6 seconds		
Number of discharge outlets	2				
Generator dimensions	Height		Diameter		
	165 mm		32 mm		
Self-activation temperature of FPC	300° C				
Classes of Fire (NFPA 2010)	A	B	C	D	K
	√	√	√	NO	NO
Generator Coverage Constraints	Min ht.: 0.45 m	Max area: 0.55 m ²			
Maximum height of installation	1.0 m				
Minimum clearance (mm)	From persons		From combustible material		From Generator Casing
	100 mm		0 mm		6.4 mm
Environmental parameters	ODP¹		GWP²		ALT³
	Zero		Zero		Negligible ⁴
Technical Parameters	Electrical conductivity			Oxygen depletion After discharge	
	Nil up to 75KV			Negligible ⁴	
Notes	1	ODP: Ozone Depletion Potential		3	ALT: Atmospheric Life Time
	2	GWP: Global Warming Potential		4	Within the parameters for use

FirePro Xtinguish Condensed Aerosol generators: FNX-20T

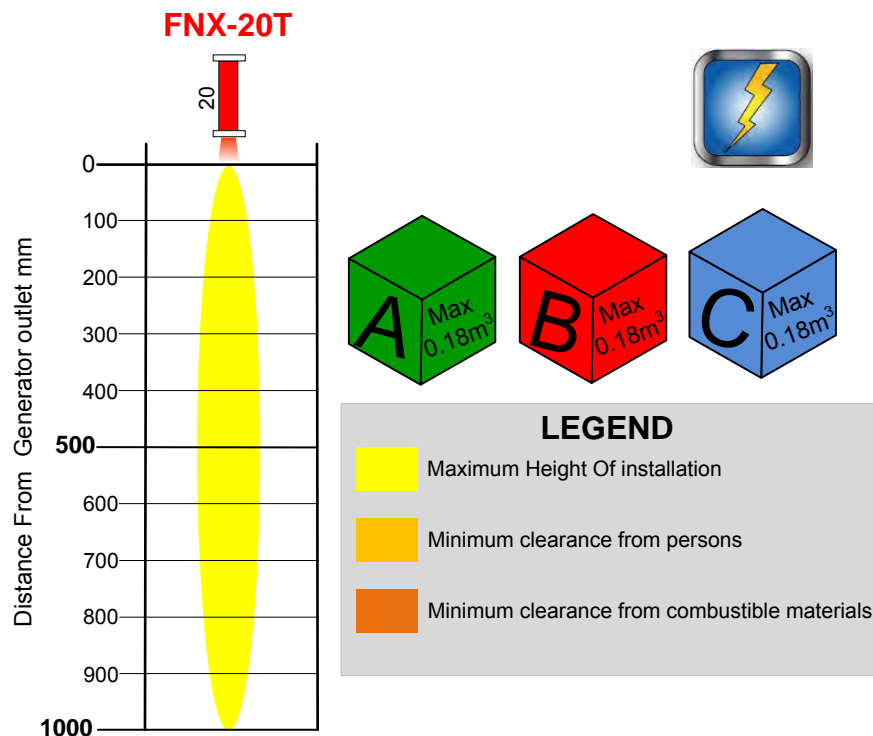

Technical Data

Mass of FPC (Aerosol Generating Solid Compound)	20 g				
Generator gross weight	Weight		Tolerance		
	310 g		± 5%		
Activation mode	Electrical				
Value of activation	6/12/24/36 V D/C 0.8 A 3-4 s				
FPC activation device	Heating elements with 1.6-3.6 Ω Resistance				
Activation line supervision current (Max)	5 mA				
Aerosol discharge time	Min.		Max		
	3 seconds		6 seconds		
Number of discharge outlets	1				
Generator dimensions	Height		Diameter		
	165 mm		32 mm		
Self-activation temperature of FPC	300° C				
Classes of Fire (NFPA 2010)	A	B	C	D	K
	√	√	√	NO	NO
Generator Coverage Constraints	Min ht.: 0.45 m	Max area: 0.55 m ²			
Maximum height of installation	1.0 m				
Minimum clearance (mm)	From persons		From combustible material		From Generator's Casing
	0 mm		0 mm		6.4 mm
Environmental parameters	ODP¹		GWP²		ALT³
	Zero		Zero		Negligible ⁴
Technical Parameters	Electrical conductivity			Oxygen depletion After discharge	
	Nil up to 75KV			Negligible ⁴	
Notes	1	ODP: Ozone Depletion Potential		3	ALT: Atmospheric Life Time
	2	GWP: Global Warming Potential		4	Within the parameters for use

FirePro Xtinguish Condensed Aerosol generators: FNX-40S

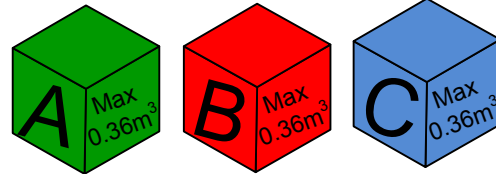
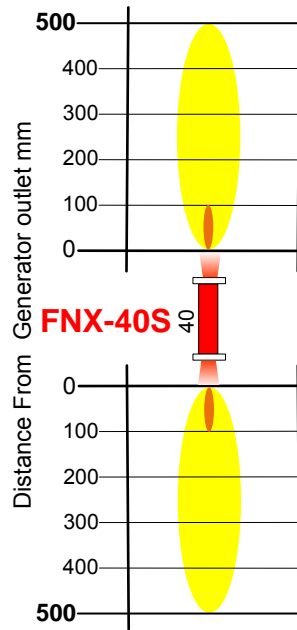

LEGEND	
	Maximum height of installation
	Minimum clearance from persons
	Minimum clearance from combustible materials

Technical Data

Mass of FPC (Aerosol Generating Solid Compound)	40 g				
Generator gross weight	Weight		Tolerance		
	610 g		± 5%		
Activation mode	Electrical				
Value of activation	6/12/24/36 V D/C 0.8 A 3-4 s				
FPC activation device	Heating elements with 1.6-3.6 Ω Resistance				
Activation line supervision current (Max)	5 mA				
Aerosol discharge time	Min.		Max		
	5 seconds		10 seconds		
Number of discharge outlets	2				
Generator dimensions	Height		Diameter		
	140 mm		51 mm		
Self-activation temperature of FPC	300° C				
Classes of Fire (NFPA 2010)	A	B	C	D	K
	√	√	√	NO	NO
Generator Coverage Constraints	Min ht.: 0.45 m		Max area: 1.08 m ²		
Maximum height of installation	1 m				
Minimum clearance (mm)	From persons		From combustible material	From Generator's Casing	
	100 mm		0 mm	6.4 mm	
Environmental parameters	ODP¹		GWP²	ALT³	
	Zero		Zero	Negligible ⁴	
Technical Parameters	Electrical conductivity			Oxygen depletion After discharge	
	Nil up to 75KV			Negligible ⁴	
Notes	1	ODP: Ozone Depletion Potential		3	ALT: Atmospheric Life Time
	2	GWP: Global Warming Potential		4	Within the parameters for use

FirePro Xtinguish Condensed Aerosol generators: FNX-40T

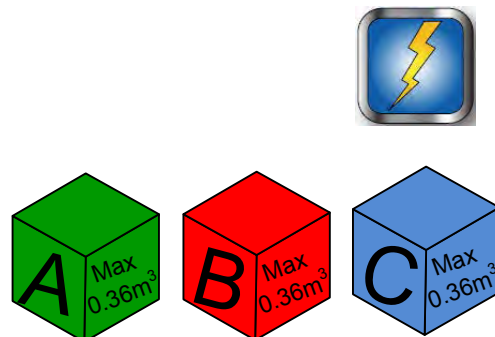
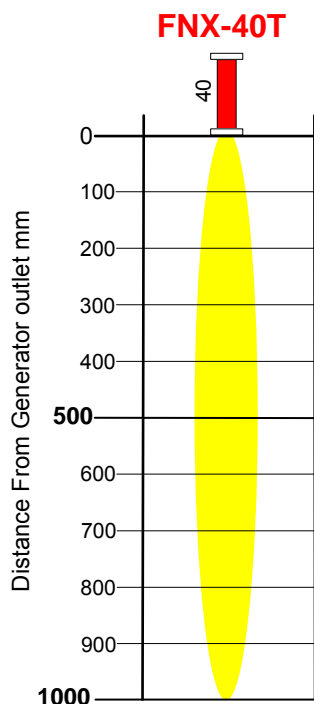

LEGEND	
	Maximum Height Of installation
	Minimum clearance from persons
	Minimum clearance from combustible materials

Technical Data

Mass of FPC (Aerosol Generating Solid Compound)	40 g				
Generators gross weight	Weight		Tolerance		
	615 g		± 5%		
Activation mode/s	Electrically				
Value of activation	6/12/24/36 V D/C 0.8 A 3-4 s				
FPC activation device	Heating elements with 1.6-3.6 Ω Resistance				
Activation line supervision current (Max)	5 mA				
Aerosol discharge time	Min.		Max		
	5 seconds		10 seconds		
Number of discharge outlet	1				
Generator dimension	Height		Diameter		
	140 mm		51 mm		
Self-activation temperature of FPC	300° C				
Classes of Fire (NFPA 2010)	A	B	C	D	K
	√	√	√	NO	NO
Generator Coverage Constraints	Min ht: 0.45 m		Max area: 1.08 m ²		
Maximum height of installation	1 m				
Minimum clearance (mm)	From persons		From combustible material		From generator casing
	0 mm		0 mm		6.4 mm
Environmental parameters	ODP¹		GWP²		ALT³
	Zero		Zero		Negligible ⁴
Technical Parameters	Electrical conductivity			Oxygen depletion After discharge	
	Nil up to 75KV			Negligible ⁴	
Note	1	ODP: Ozone Depletion Potential		3	ALT: Atmospheric Life Time
	2	GWP: Global Warming Potential		4	Within the parameters for use

FirePro Xtinguish Condensed Aerosol generators: FNX-80S

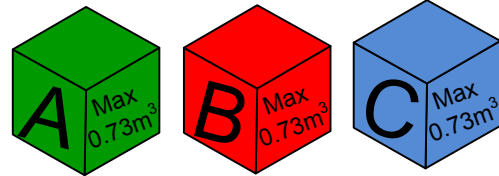
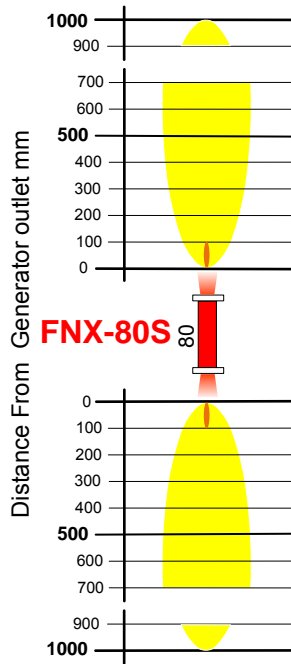

LEGEND

- Maximum height of installation
- Minimum clearance from persons
- Minimum clearance from combustible materials

Technical Data

Mass of FPC (Aerosol Generating Solid Compound)	80 g				
Generator gross weight	Weight		Tolerance		
	870 g		± 5%		
Activation mode	Electrically				
Value of activation	6/12/24/36 V D/C 0.8 A 3-4 s				
FPC activation device	Heating elements with 1.6-3.6 Ω Resistance				
Activation line supervision current (Max)	5 mA				
Aerosol discharge time	Min.		Max		
	5 seconds		10 seconds		
Number of discharge outlets	2				
Generator dimensions	Height		Diameter		
	185 mm		51 mm		
Self-activation temperature of FPC	300° C				
Classes of Fire (NFPA 2010)	A	B	C	D	K
	√	√	√	NO	NO
Generator Coverage Constraints	Min ht.: 0.45 m		Max area: 2.12 m ²		
Maximum height of installation	2 m				
Minimum clearance (mm)	From persons		From combustible material	From Generator Casing	
	100 mm		0 mm	6.4 mm	
Environmental parameters	ODP¹		GWP²	ALT³	
	Zero		Zero	Negligible ⁴	
Technical Parameters	Electrical conductivity			Oxygen depletion After discharge	
	Nil up to 75KV			Negligible ⁴	
Notes	1	ODP: Ozone Depletion Potential		3	ALT: Atmospheric Life Time
	2	GWP: Global Warming Potential		4	Within the parameters for use

FirePro Xtinguish Condensed Aerosol generators: FNX-80T

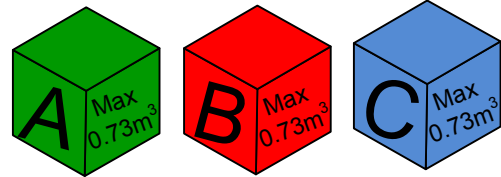
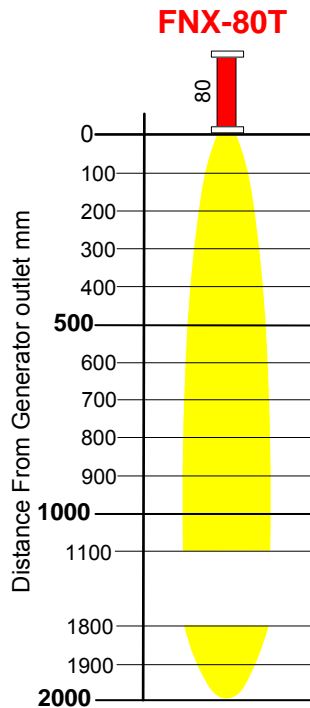

LEGEND

- Maximum Height Of installation
- Minimum clearance from persons
- Minimum clearance from combustible materials

Technical Data

Mass of FPC (Aerosol Generating Solid Compound)	80 g				
Generators gross weight	Weight		Tolerance		
	840 g		± 5%		
Activation mode/s	Electrically				
Value of activation	6/12/24/36 V D/C 0.8 A 3-4 s				
FPC activation device	Heating elements with 1.6-3.6 Ω Resistance				
Activation line supervision current (Max)	5 mA				
Aerosol discharge time	Min.		Max		
	5 seconds		10 seconds		
Number of discharge outlet	1				
Generator dimension	Height		Diameter		
	185 mm		51 mm		
Self-activation temperature of FPC	300° C				
Classes of Fire (NFPA 2010)	A	B	C	D	K
	√	√	√	NO	NO
Generator Coverage Constraints	Min ht: 0.45 m		Max area: 2.12 m ²		
Maximum height of installation	2 m				
Minimum clearance (mm)	From persons		From combustible material		From generator casing
	0 mm		0 mm		6.4 mm
Environmental parameters	ODP¹		GWP²		ALT³
	Zero		Zero		Negligible ⁴
Technical Parameters	Electrical conductivity			Oxygen depletion After discharge	
	Nil up to 75KV			Negligible ⁴	
Note	1	ODP: Ozone Depletion Potential		3	ALT: Atmospheric Life Time
	2	GWP: Global Warming Potential		4	Within the parameters for use

FirePro Xtinguish Condensed Aerosol generators: FNX-100S

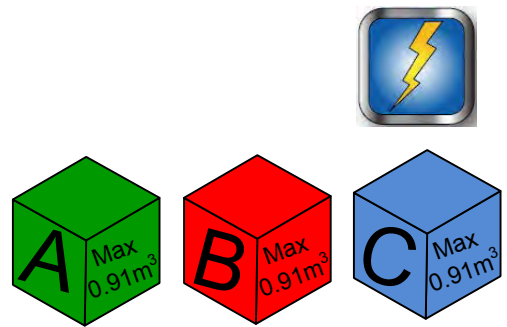
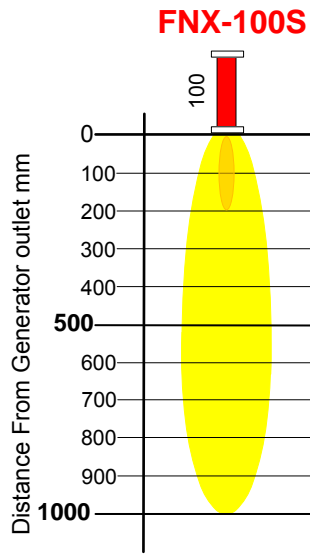

LEGEND

- Maximum Height Of installation
- Minimum clearance from persons
- Minimum clearance from combustible materials

Technical Data

Mass of FPC (Aerosol Generating Solid Compound)	100 g				
Generators gross weight	Weight		Tolerance		
	1370 g		± 5%		
Activation mode/s	Electrically				
Value of activation	6/12/24/36 V D/C 0.8 A 3-4 s				
FPC activation device	Heating elements with 1.6-3.6 Ω Resistance				
Activation line supervision current (Max)	5 mA				
Aerosol discharge time	Min.		Max		
	5 seconds		10 seconds		
Number of discharge outlet	1				
Generator dimension	Height		Diameter		
	155 mm		84 mm		
Self-activation temperature of FPC	300° C				
Classes of Fire (NFPA 2010)	A	B	C	D	K
	√	√	√	NO	NO
Generator Coverage Constraints	Min ht: 0.45 m		Max area: 2.65 m ²		
Maximum height of installation	2 m				
Minimum clearance (mm)	From persons		From combustible material		From generator casing
	200 mm		0 mm		6.4 mm
Environmental parameters	ODP¹		GWP²		ALT³
	Zero		Zero		Negligible ⁴
Technical Parameters	Electrical conductivity			Oxygen depletion After discharge	
	Nil up to 75KV			Negligible ⁴	
Note	1	ODP: Ozone Depletion Potential		3	ALT: Atmospheric Life Time
	2	GWP: Global Warming Potential		4	Within the parameters for use

FirePro Xtinguish Condensed Aerosol generators: FNX-200S

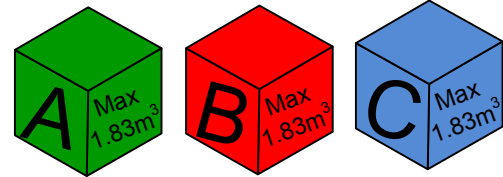
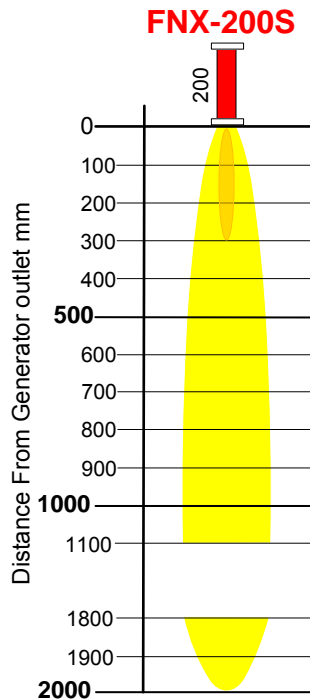

LEGEND	
	Maximum Height Of installation
	Minimum clearance from persons
	Minimum clearance from combustible materials

Technical Data

Mass of FPC (Aerosol Generating Solid Compound)	200 g				
Generators gross weight	Weight		Tolerance		
	1840 g		± 5%		
Activation mode/s	Electrically				
Value of activation	6/12/24/36 V D/C 0.8 A 3-4 s				
FPC activation device	Heating elements with 1.6-3.6 Ω Resistance				
Activation line supervision current (Max)	5 mA				
Aerosol discharge time	Min.		Max		
	5 seconds		10 seconds		
Number of discharge outlet	1				
Generator dimension	Height		Diameter		
	185 mm		84 mm		
Self-activation temperature of FPC	300° C				
Classes of Fire (NFPA 2010)	A	B	C	D	K
	√	√	√	NO	NO
Generator Coverage Constraints	Min ht: 0.45 m		Max area: 5.29 m ²		
Maximum height of installation	2 m				
Minimum clearance (mm)	From persons		From combustible material	From generator casing	
	300 mm		0 mm	6.4 mm	
Environmental parameters	ODP ¹		GWP ²	ALT ³	
	Zero		Zero	Negligible ⁴	
Technical Parameters	Electrical conductivity		Oxygen depletion After discharge		
	Nil up to 75KV		Negligible ⁴		
Note	1	ODP: Ozone Depletion Potential		3	ALT: Atmospheric Life Time
	2	GWP: Global Warming Potential		4	Within the parameters for use

FirePro Xtinguish Condensed Aerosol generators: FNX-500S

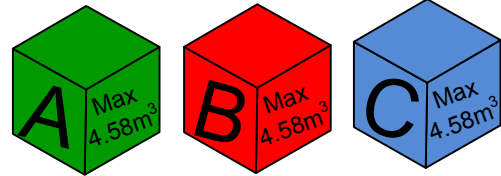
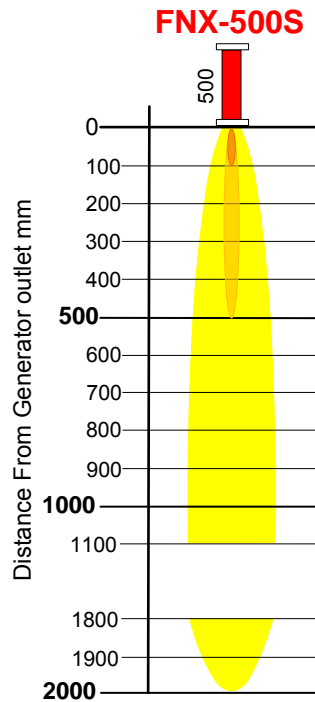

LEGEND

- Maximum Height Of installation
- Minimum clearance from persons
- Minimum clearance from combustible materials

Technical Data

Mass of FPC (Aerosol Generating Solid Compound)	500 g				
Generators gross weight	Weight		Tolerance		
	3340 g		± 5%		
Activation mode/s	Electrically				
Value of activation	6/12/24/36 V D/C 0.8 A 3-4 s				
FPC activation device	Heating elements with 1.6-3.6 Ω Resistance				
Activation line supervision current (Max)	5 mA				
Aerosol discharge time	Min.		Max		
	5 seconds		10 seconds		
Number of discharge outlet	1				
Generator dimension	Height		Diameter		
	295 mm		84 mm		
Self-activation temperature of FPC	300° C				
Classes of Fire (NFPA 2010)	A	B	C	D	K
	√	√	√	NO	NO
Generator Coverage Constraints	Min ht: 0.45 m		Max area: 5.29 m ²		
Maximum height of installation	2 m				
Minimum clearance (mm)	From persons		From combustible material	From generator casing	
	500 mm		100 mm	6.4 mm	
Environmental parameters	ODP¹		GWP²	ALT³	
	Zero		Zero	Negligible ⁴	
Technical Parameters	Electrical conductivity			Oxygen depletion After discharge	
	Nil up to 75KV			Negligible ⁴	
Note	1	ODP: Ozone Depletion Potential		3	ALT: Atmospheric Life Time
	2	GWP: Global Warming Potential		4	Within the parameters for use

FirePro Xtinguish Condensed Aerosol generators: FNX-1200 / FNX-1200S/T/Ts



FNX-1200/S/T/Ts

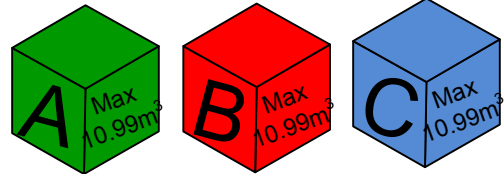
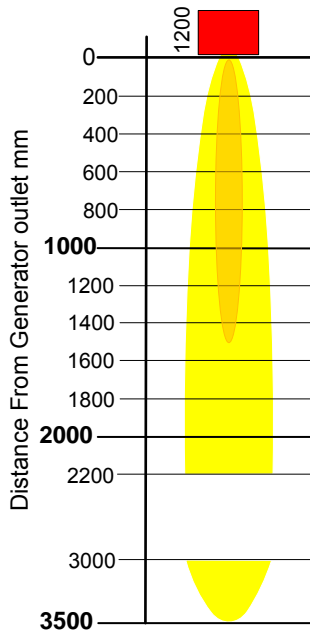

LEGEND

- Maximum Height Of installation
- Minimum clearance from persons
- Minimum clearance from combustible materials

Technical Data

Mass of FPC (Aerosol Generating Solid Compound)	1200 g				
Generator gross weight	Weight	Tolerance			
	10900 g	± 5%			
Activation mode/s	Electrically				
Value of activation	6/12/24/36 VDC 0.8A 3 – 4 sec				
FPC activation device	Heating element with 1.6 – 3.6 Ω resistance				
Activation line supervision current (Max)	5 mA				
Aerosol discharge time	Min	Max			
	15 seconds	20 seconds			
Number of discharge outlet	1				
Generator dimension	Height	Width	Length		
	167 mm	216 mm	300 mm		
Self-activation temperature of FPC	300 °C				
Classes of Fire (NFPA 2010)	A	B	C	D	K
	Yes	Yes	Yes	No	No
Generator Coverage Constraints	Min ht: 0.45 m		Max area: 32 m ²		
Maximum height of installation	3.5 m				
Minimum clearance (mm)	From Personnel		From combustible material	From generator casing	
	1500 mm		0 mm	6.4 mm	
Environmental parameters	ODP¹		GWP²	ALT³	
	Zero		Zero	Negligible ⁴	
Technical Parameters	Electrical Conductivity			Oxygen depletion after discharge	
	Nil up to 75KV			Negligible ⁴	
Notes	1	ODP: Ozone Depletion Potential		3	ALT: Atmospheric Lifetime
	2	GWP: Global Warming Potential		4	Within the parameters for use

FirePro Xtinguish Condensed Aerosol generators: FNX-2000 / FNX-2000S/T/TS

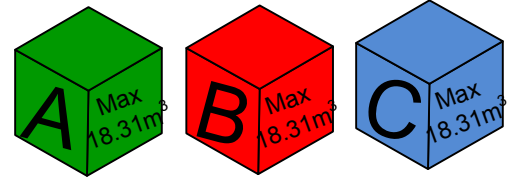
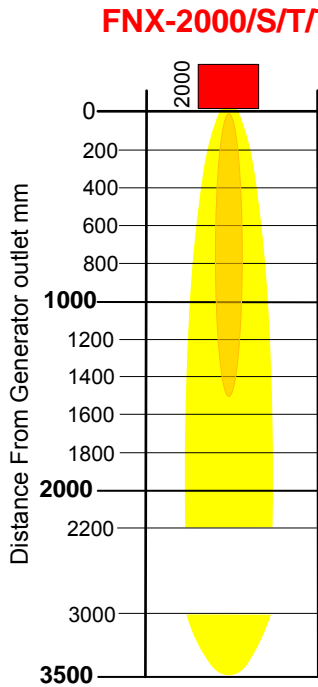

LEGEND

- Maximum Height Of installation
- Minimum clearance from persons
- Minimum clearance from combustible materials

Technical Data

Mass of FPC (Aerosol Generating Solid Compound)	2000 g			
Generator gross weight	Weight	Tolerance		
	15500 g	± 5%		
Activation mode/s	Electrically			
Value of activation	6/12/24/36 VDC 0.8A 3 – 4 sec			
FPC activation device	Heating element with 1.6 – 3.6 Ω resistance			
Activation line supervision current (Max)	5 mA			
Aerosol discharge time	Min	Max		
	15 seconds	20 seconds		
Number of discharge outlet	1			
Generator dimension	Height	Width	Length	
	185 mm	300 mm	300 mm	
Self-activation temperature of FPC	300 °C			
Classes of Fire (NFPA 2010)	A	B	C	D
	Yes	Yes	Yes	No
Generator Coverage Constraints	Min ht: 0.45 m		Max area: 32.03 m ²	
Maximum height of installation	3.5 m			
Minimum clearance (mm)	From Personnel		From combustible material	From generator casing
	1500 mm		0 mm	6.4 mm
Environmental parameters	ODP¹		GWP²	ALT³
	Zero		Zero	Negligible ⁴
Technical Parameters	Electrical Conductivity			Oxygen depletion after discharge
	Nil up to 75KV			Negligible ⁴
Notes	1	ODP: Ozone Depletion Potential	3	ALT: Atmospheric Lifetime
	2	GWP: Global Warming Potential	4	Within the parameters for use

FirePro Xtinguish Condensed Aerosol generators: FNX-3000 / FNX-3000S/T/TS



FNX-3000/S/T/TS

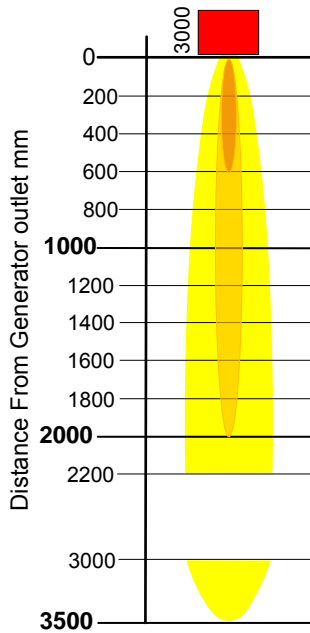

LEGEND

- Maximum Height Of installation
- Minimum clearance from persons
- Minimum clearance from combustible materials

Technical Data

Mass of FPC (Aerosol Generating Solid Compound)	3000 g			
Generator gross weight	Weight	Tolerance		
	16300 g	± 5%		
Activation mode/s	Electrically			
Value of activation	6/12/24/36 VDC 0.8A 3 – 4 sec			
FPC activation device	Heating element with 1.6 – 3.6 Ω resistance			
Activation line supervision current (Max)	5 mA			
Aerosol discharge time	Min	Max		
	15 seconds	20 seconds		
Number of discharge outlet	1			
Generator dimension	Height	Width	Length	
	185 mm	300 mm	300 mm	
Self-activation temperature of FPC	300 °C			
Classes of Fire (NFPA 2010)	A	B	C	D
	Yes	Yes	Yes	No
Generator Coverage Constraints	Min ht: 0.45 m		Max area: 32.03 m ²	
Maximum height of installation	3.5 m			
Minimum clearance (mm)	From Personnel		From combustible material	From generator casing
	2000 mm		600 mm	6.4 mm
Environmental parameters	ODP¹		GWP²	ALT³
	Zero		Zero	Negligible ⁴
Technical Parameters	Electrical Conductivity		Oxygen depletion after discharge	
	Nil up to 75KV		Negligible ⁴	
Notes	1	ODP: Ozone Depletion Potential	3	ALT: Atmospheric Lifetime
	2	GWP: Global Warming Potential	4	Within the parameters for use

FirePro Xtinguish Condensed Aerosol generators: FNX-4200T/TS

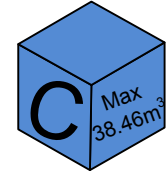
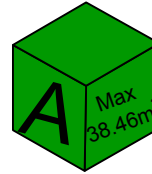
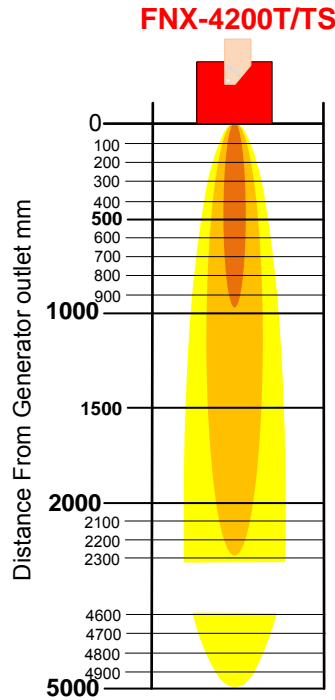

LEGEND	
	Maximum Height Of Installation
	Minimum clearance from persons
	Minimum clearance from combustible materials

Technical Data

Mass of FPC (Aerosol Generating Solid Compound)	4200 g				
Generators gross weight	Weight	Tolerance			
	23600 g	± 5%			
Activation mode/s	Electrically				
Value of activation	6/12/24/36 V D/C 0.8 A 3-4 s				
FPC activation device	Heating elements with 1.6-3.6 Ω Resistance				
Activation line supervision current (Max)	5 mA				
Aerosol discharge time	Min.	Max			
	15 seconds	20 seconds			
Number of discharge outlet	1				
Generator dimension	Height	Width	Length		
	300 mm	300 mm	300 mm		
Self-activation temperature of FPC	300° C				
Classes of Fire (NFPA 2010)	A	B	C	D	K
	√	√	√	NO	NO
Generator Coverage Constraints	Min ht.: 0.45 m		Max area: 32 m ²		
Maximum height of installation	5 m				
Minimum clearance (mm)	From persons	From combustible material	From Generator Casing		
	2300 mm	990 mm	6.4 mm		
Environmental parameters	ODP¹	GWP²	ALT³		
	Zero	Zero	Negligible ⁴		
Technical Parameters	Electrical conductivity			Oxygen depletion After discharge	
	Nil up to 75KV			Negligible ⁴	
Note	1	ODP: Ozone Depletion Potential	3	ALT: Atmospheric Life Time	
	2	GWP: Global Warming Potential	4	Within the parameters for use	

FirePro Xtinguish Condensed Aerosol generators: FNX-5700 / FNX-5700S/T/TTS

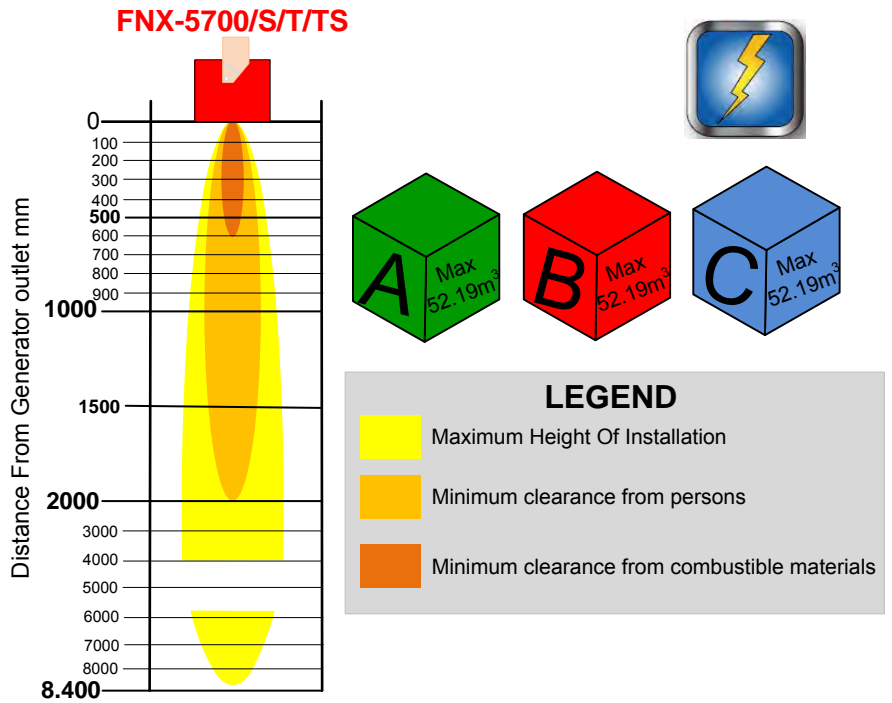
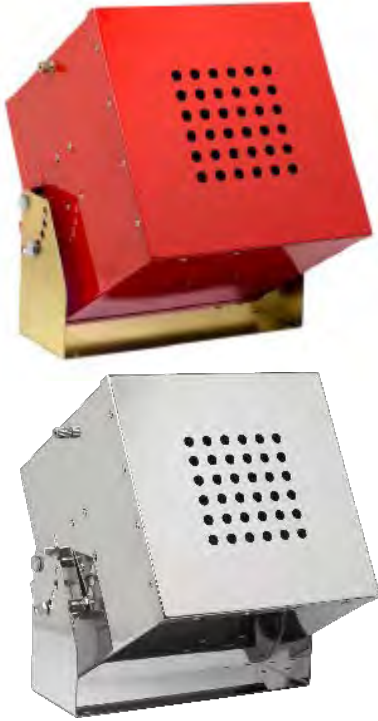

Technical Data

Mass of FPC (Aerosol Generating Solid Compound)	5700 g				
Generators gross weight	Weight	Tolerance			
	26400 g	± 5%			
Activation mode/s	Electrically				
Value of activation	6/12/24/36 V D/C 0.8 A 3-4 s				
FPC activation device	Heating elements with 1.6-3.6 Ω Resistance				
Activation line supervision current (Max)	5 mA				
Aerosol discharge time	Min.	Max			
	15 seconds	20 seconds			
Number of discharge outlet	1				
Generator dimension	Height	Width	Length		
	300 mm	300 mm	300 mm		
Self-activation temperature of FPC	300° C				
Classes of Fire (NFPA 2010)	A	B	C	D	K
	√	√	√	NO	NO
Generator Coverage Constraints	Min ht.: 0.45 m		Max area: 32 m ²		
Maximum height of installation	8.4 m				
Minimum clearance (mm)	From persons	From combustible material		From Generator Casing	
	2000 mm	600 mm		6.4 mm	
Environmental parameters	ODP¹		GWP²		ALT³
	Zero		Zero		Negligible ⁴
Technical Parameters	Electrical conductivity			Oxygen depletion After discharge	
	Nil up to 75KV			Negligible ⁴	
Note	1	ODP: Ozone Depletion Potential		3	ALT: Atmospheric Life Time
	2	GWP: Global Warming Potential		4	Within the parameters for use

19 Appendix D – FirePro Xtinguish Generator Drawings

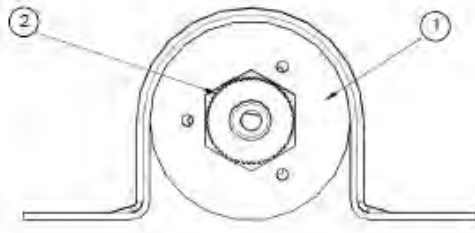
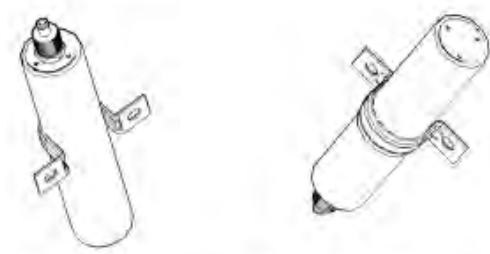
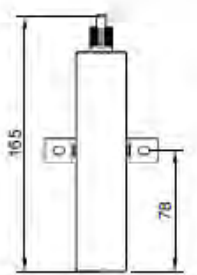
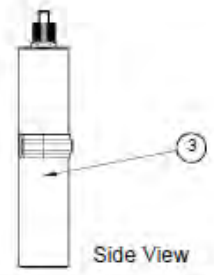
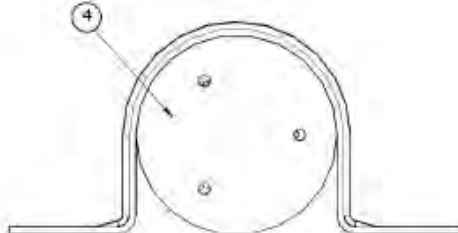
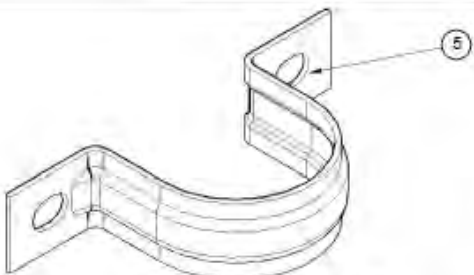
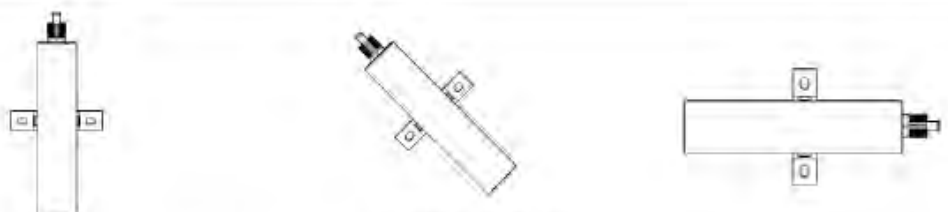
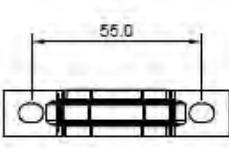
 <p>Top View</p>	 <p>Iso View (Top) Iso View (Bottom)</p>																												
 <p>Front View</p>	 <p>Side View</p>																												
 <p>Bottom View</p>	 <p>Isometric View of Bracket</p>																												
 <p>Installation Options</p>																													
 <p>Fixing Drills</p>	<table border="1" style="width: 100%; border-collapse: collapse;"> <tr> <td style="width: 5%;">5</td> <td style="width: 5%;">1</td> <td style="width: 80%;">BRACKET</td> <td style="width: 10%;"></td> </tr> <tr> <td>4</td> <td>1</td> <td>BOTTOM OUTLET COVER PLATE</td> <td></td> </tr> <tr> <td>3</td> <td>1</td> <td>HOUSING TUBE</td> <td></td> </tr> <tr> <td>2</td> <td>1</td> <td>THERMOCONNECTOR</td> <td></td> </tr> <tr> <td>1</td> <td>1</td> <td>TOP OUTLET COVER PLATE</td> <td></td> </tr> <tr> <td>Position</td> <td>Quantity</td> <td>Denomination</td> <td></td> </tr> <tr> <td colspan="4" style="text-align: center;">PART LIST</td> </tr> </table>	5	1	BRACKET		4	1	BOTTOM OUTLET COVER PLATE		3	1	HOUSING TUBE		2	1	THERMOCONNECTOR		1	1	TOP OUTLET COVER PLATE		Position	Quantity	Denomination		PART LIST			
5	1	BRACKET																											
4	1	BOTTOM OUTLET COVER PLATE																											
3	1	HOUSING TUBE																											
2	1	THERMOCONNECTOR																											
1	1	TOP OUTLET COVER PLATE																											
Position	Quantity	Denomination																											
PART LIST																													
<p>FirePro. Xtinguish FNX-20S</p>																													
<p>TITLE: INSTALLATION DRAWING</p>																													

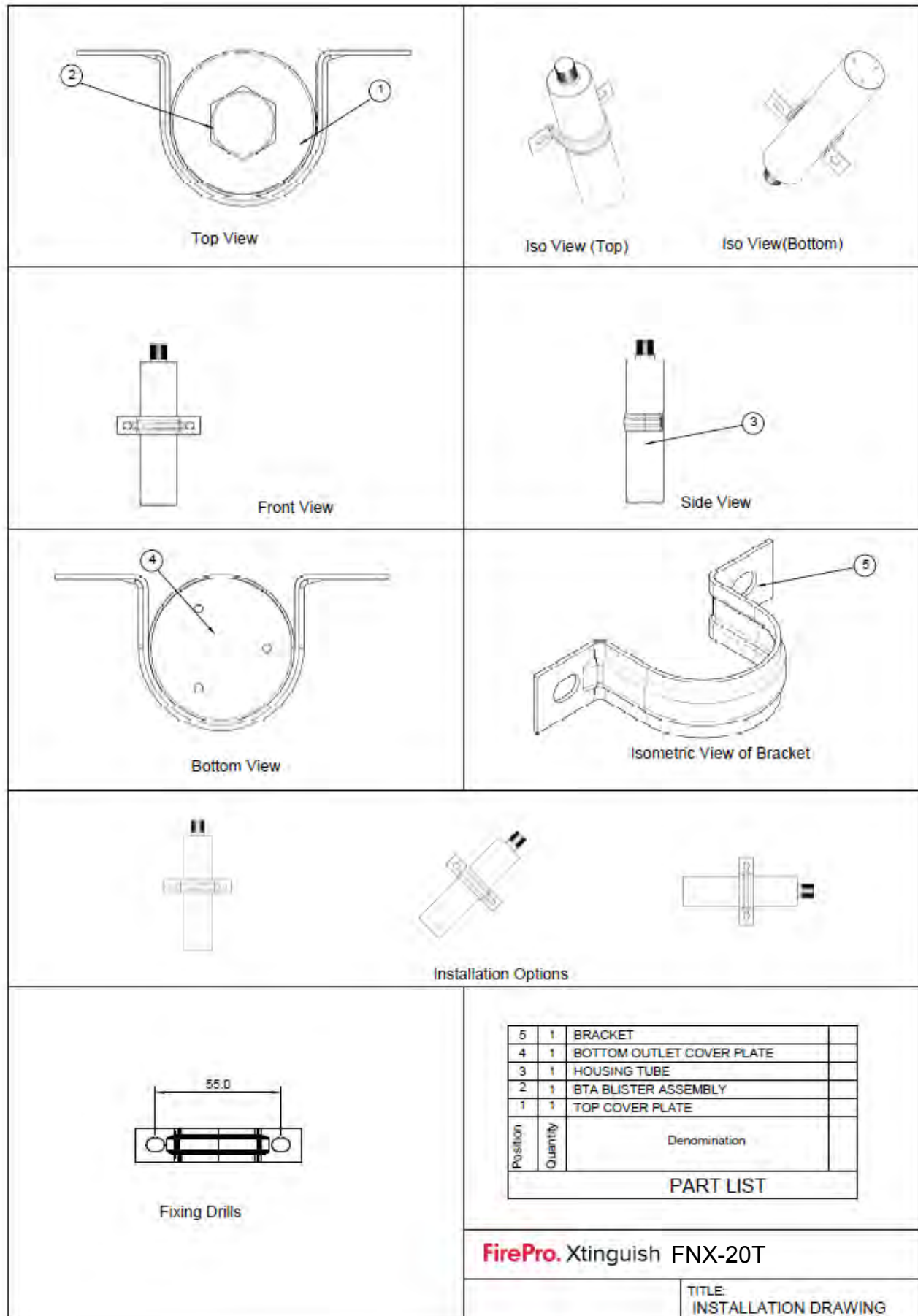

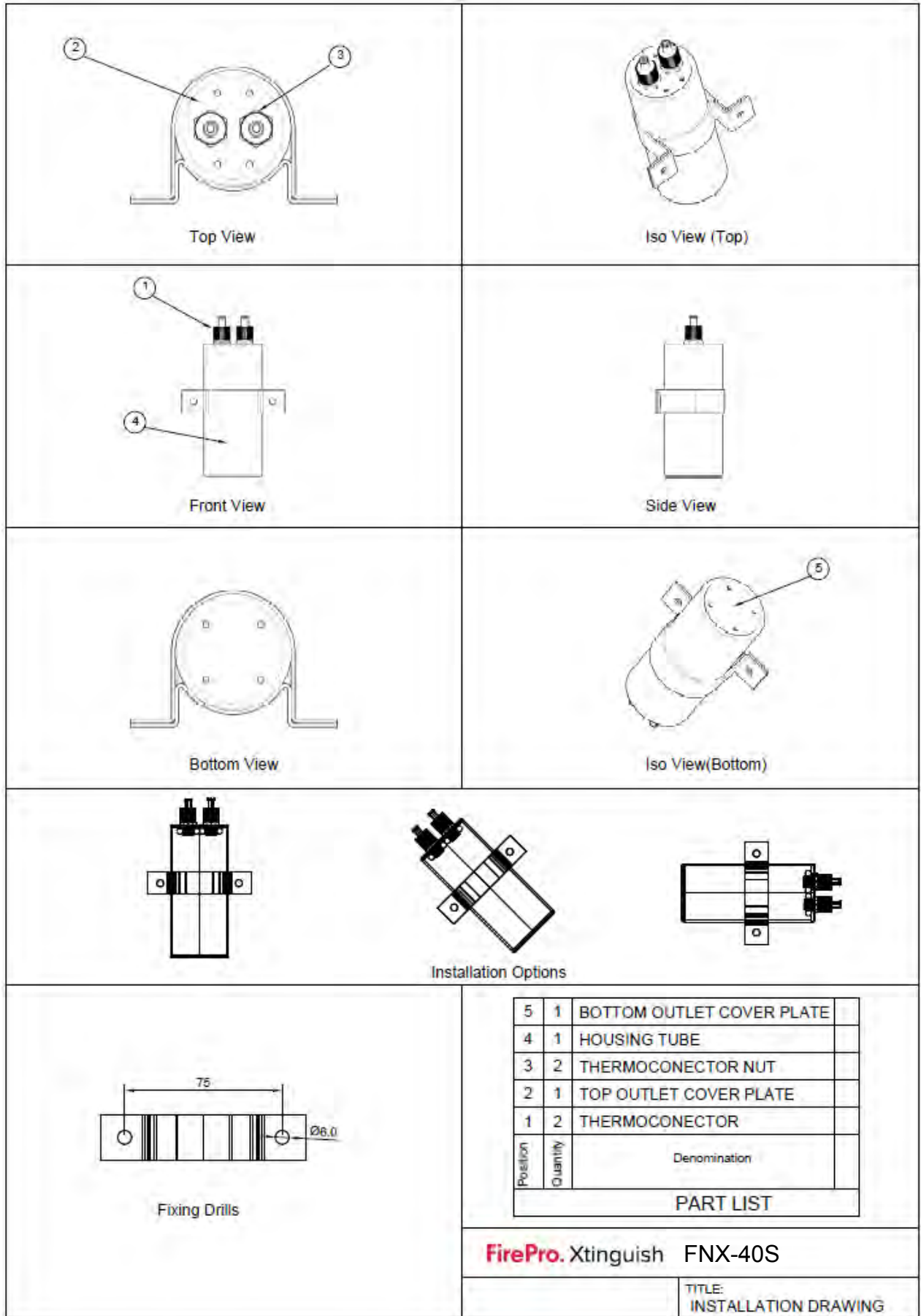

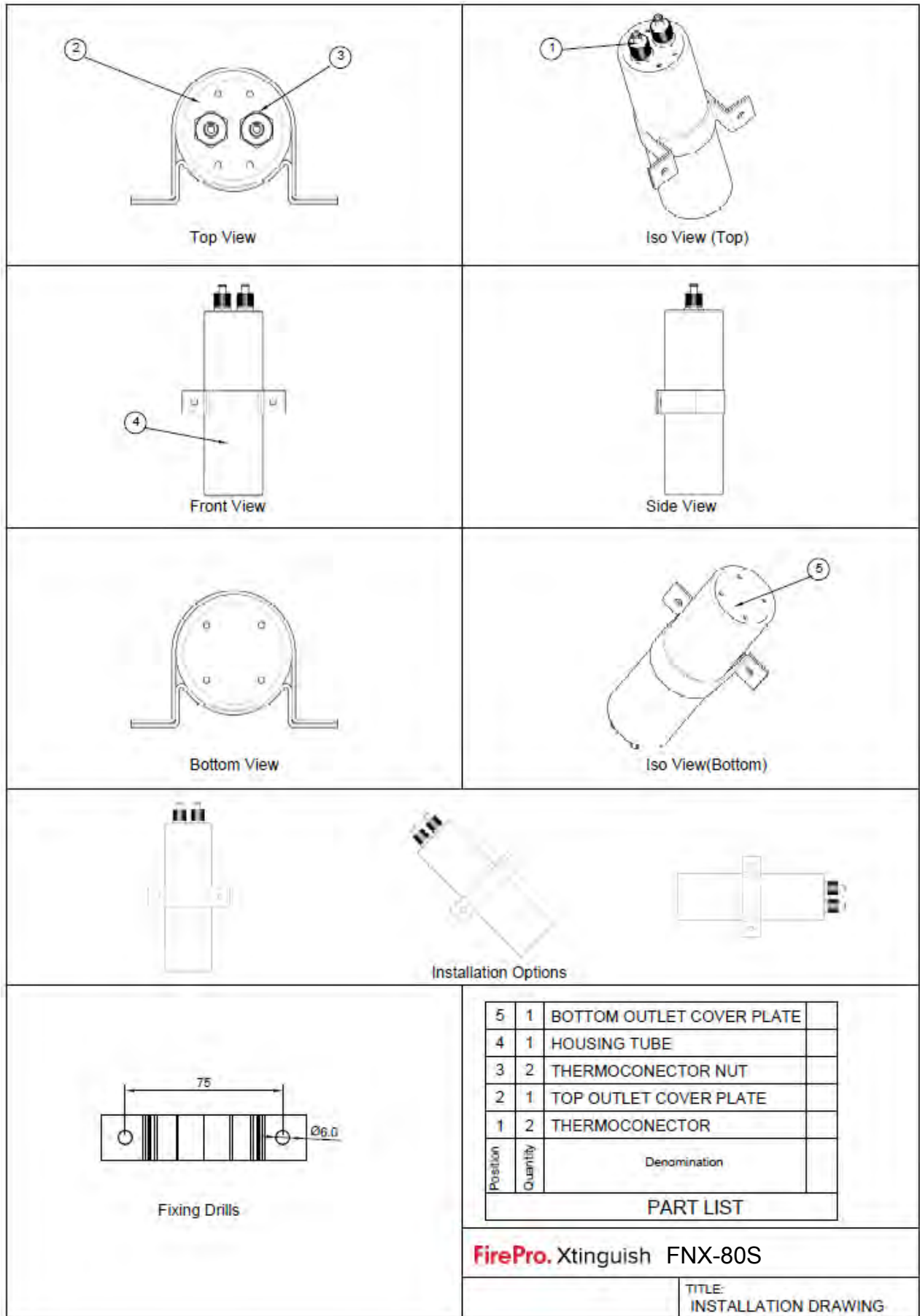

5	1	BOTTOM OUTLET COVER PLATE	
4	1	HOUSING TUBE	
3	2	THERMOCONNECTOR NUT	
2	1	TOP OUTLET COVER PLATE	
1	2	THERMOCONNECTOR	
Position	Quantity	Denomination	
PART LIST			

FirePro. Xtinguish FNX-80S

TITLE:
INSTALLATION DRAWING

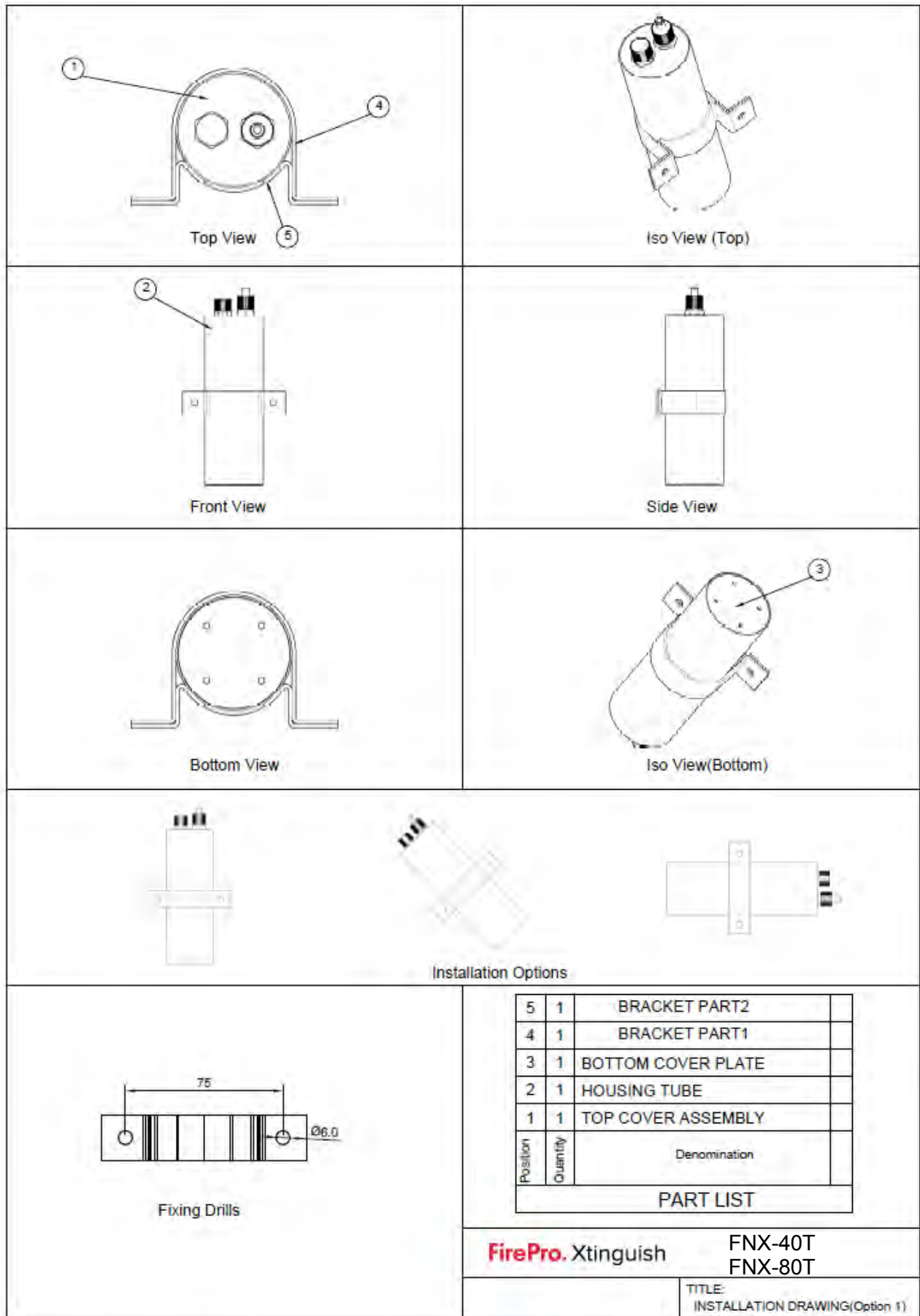

5	1	BRACKET PART2	
4	1	BRACKET PART1	
3	1	BOTTOM COVER PLATE	
2	1	HOUSING TUBE	
1	1	TOP COVER ASSEMBLY	
Position	Quantity	Denomination	
PART LIST			

FirePro. Xtinguish

FNX-40T

FNX-80T

TITLE:
INSTALLATION DRAWING(Option 1)

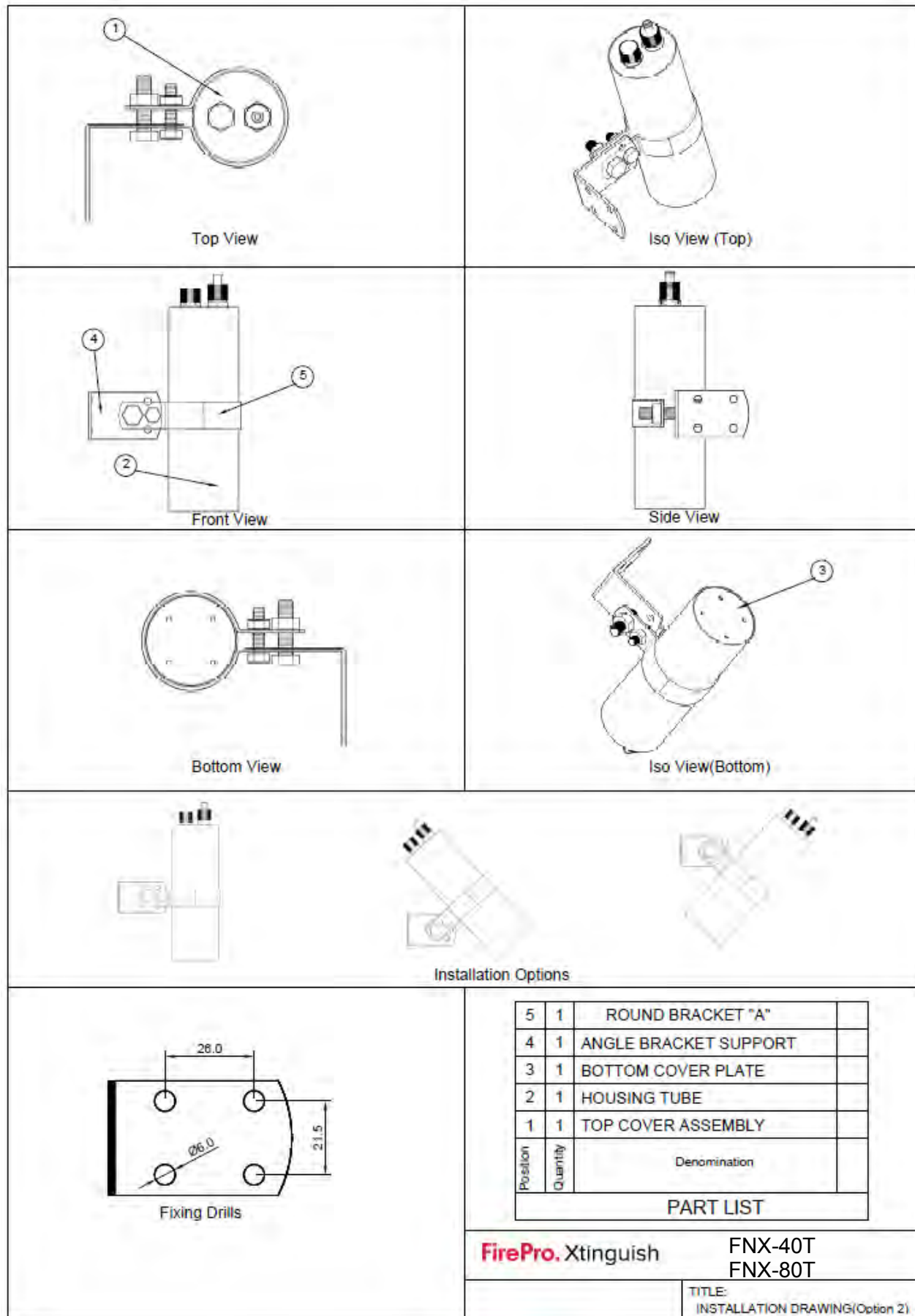

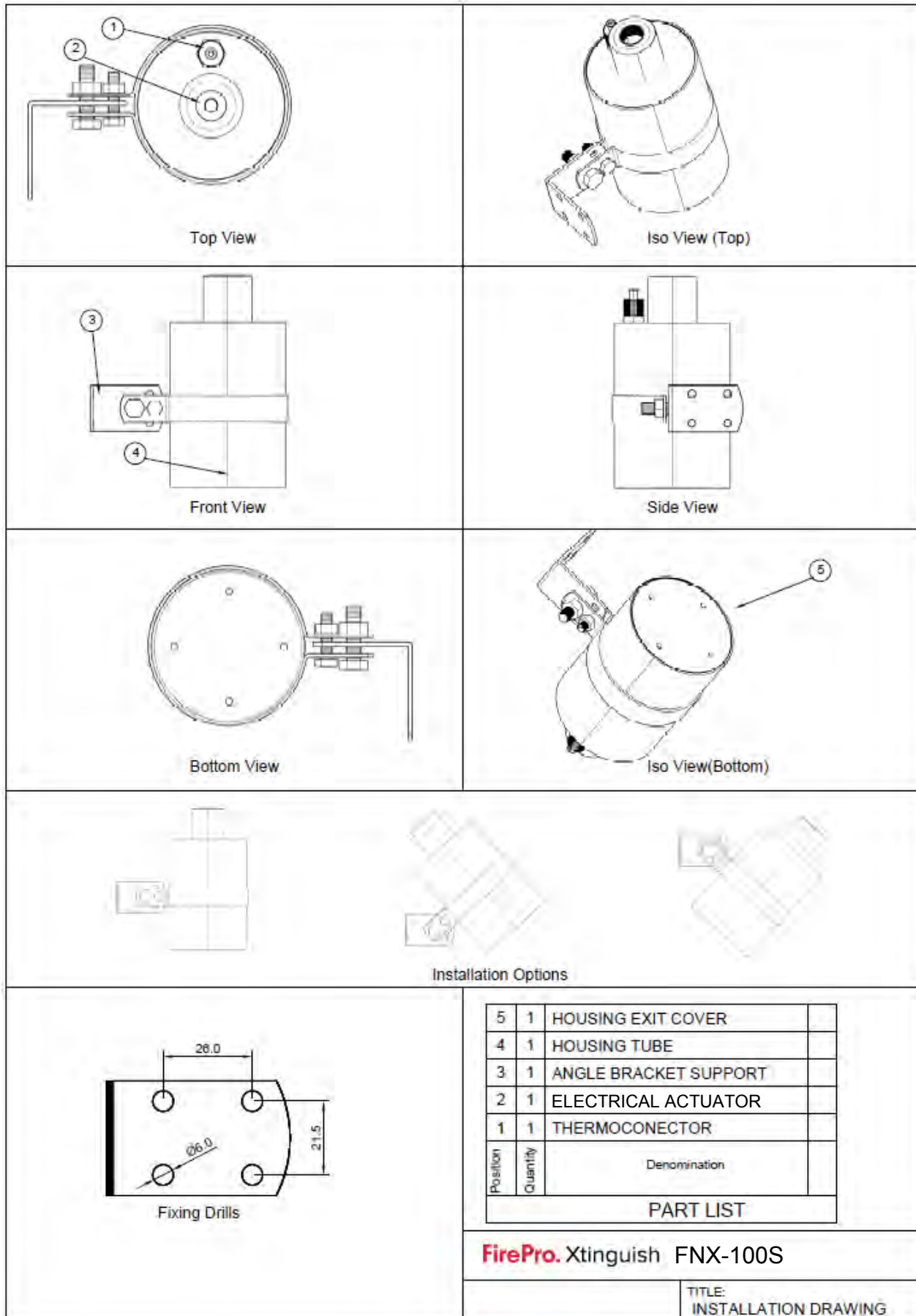

5	1	HOUSING EXIT COVER	
4	1	HOUSING TUBE	
3	1	ANGLE BRACKET SUPPORT	
2	1	ELECTRICAL ACTUATOR	
1	1	THERMOCONNECTOR	
Position	Quantity	Denomination	
PART LIST			

FirePro. Xtinguish FNX-100S

TITLE:
INSTALLATION DRAWING

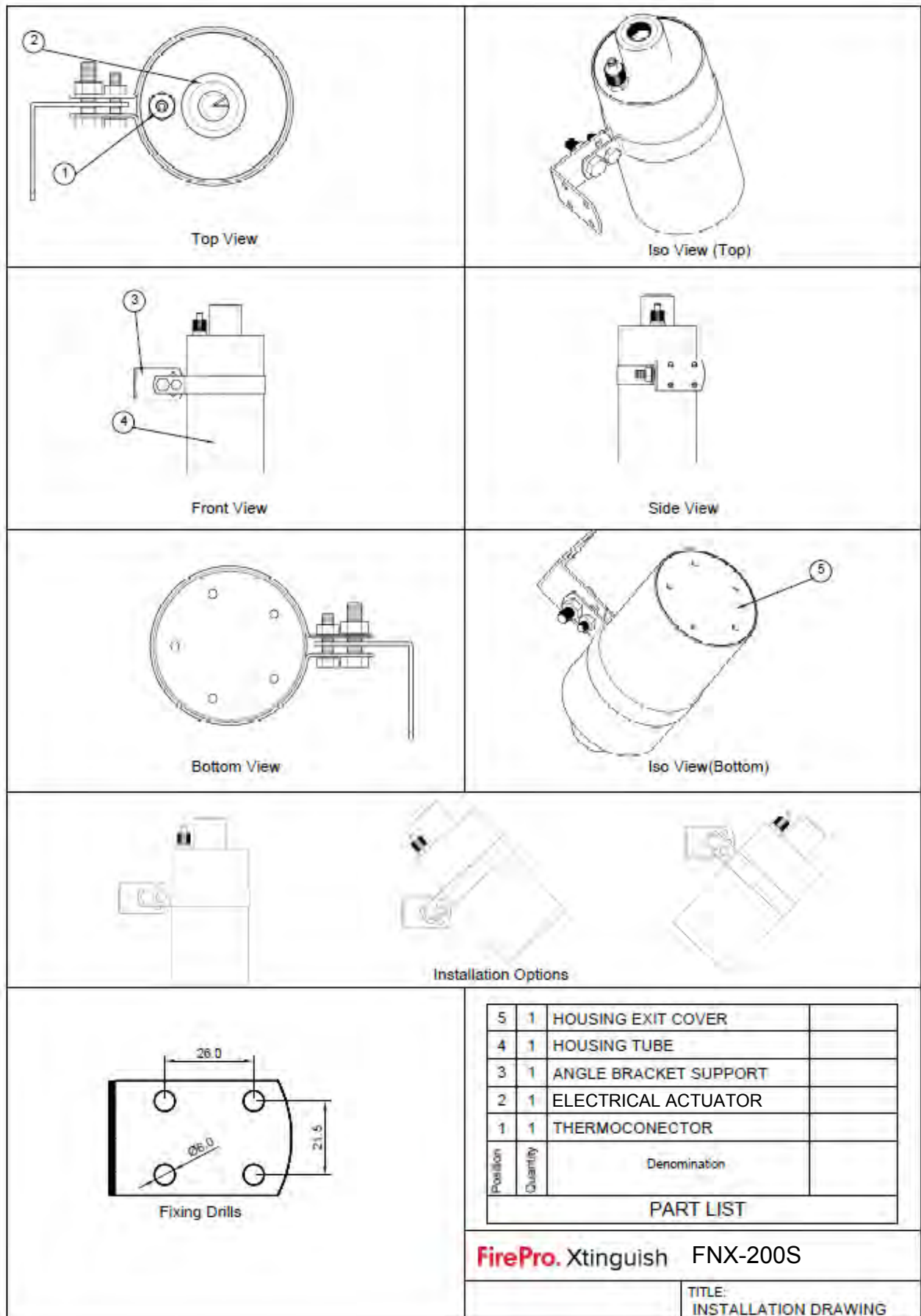

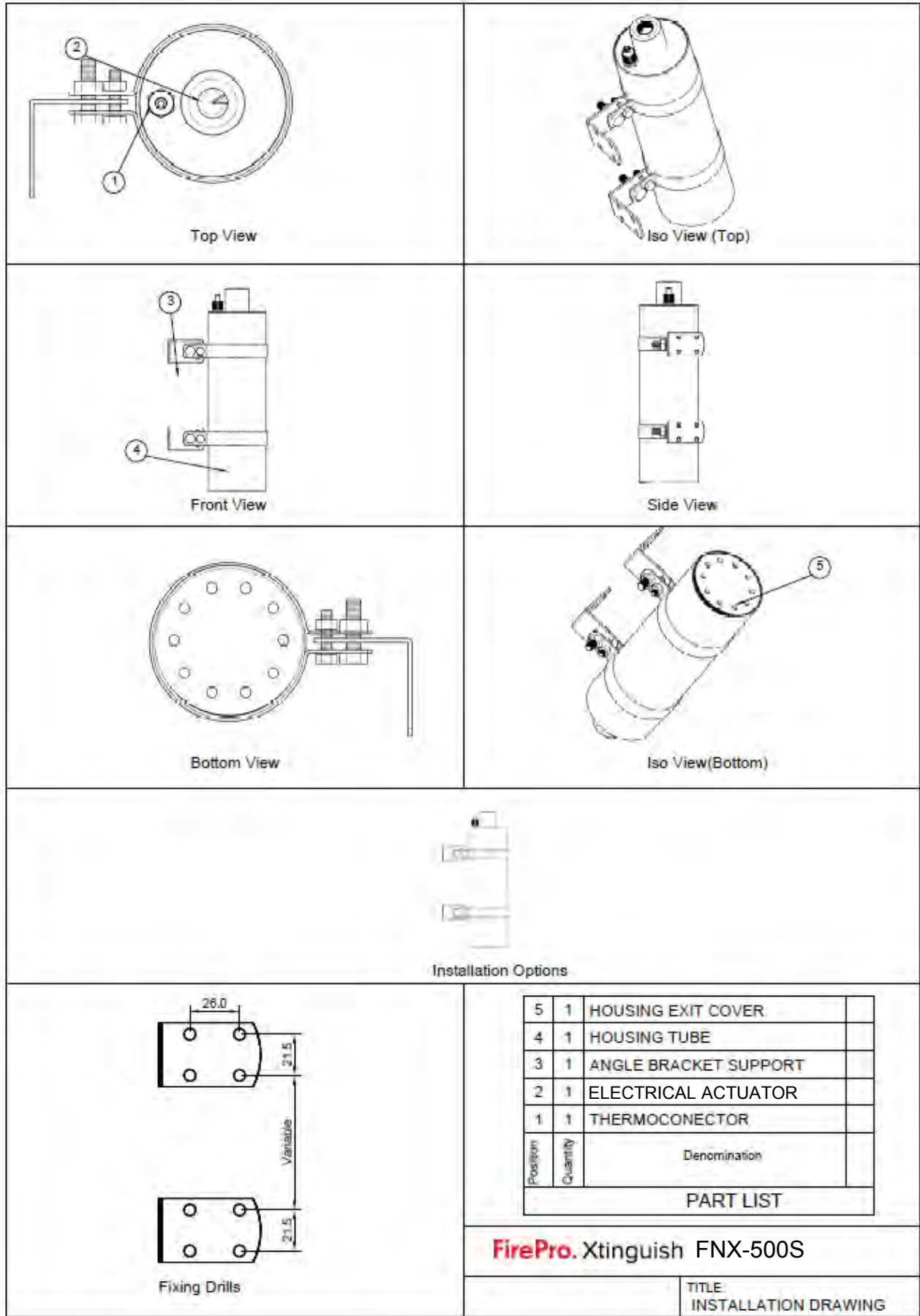

5	1	HOUSING EXIT COVER	
4	1	HOUSING TUBE	
3	1	ANGLE BRACKET SUPPORT	
2	1	ELECTRICAL ACTUATOR	
1	1	THERMOCONNECTOR	
Position	Quantity	Denomination	
PART LIST			

FirePro. Xtinguish FNX-500S

TITLE
INSTALLATION DRAWING

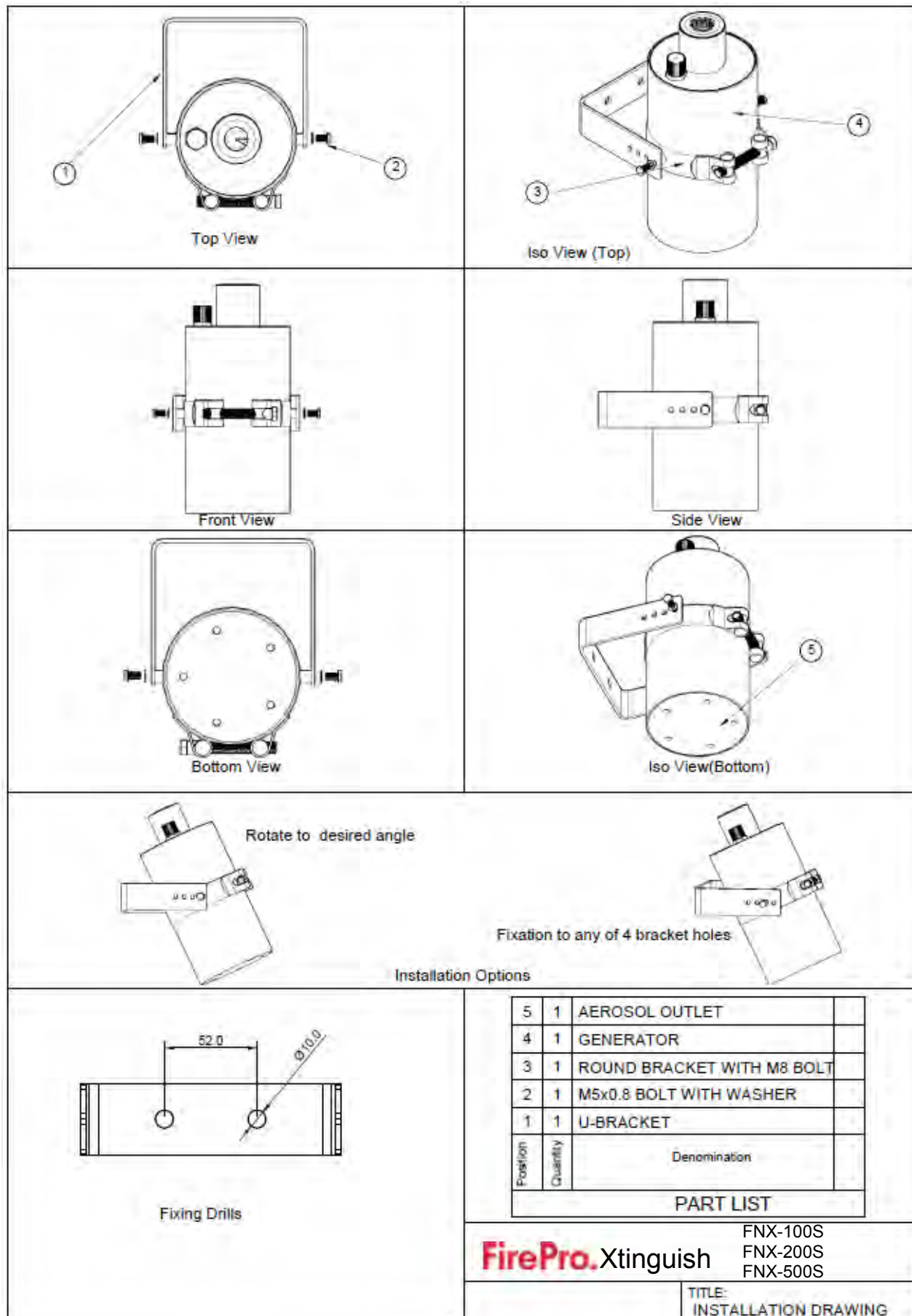

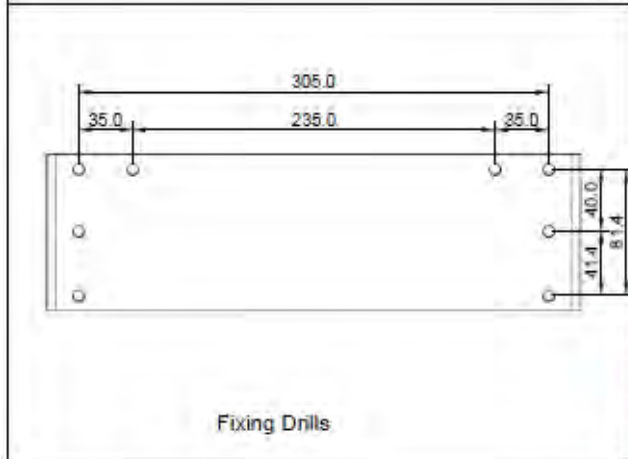
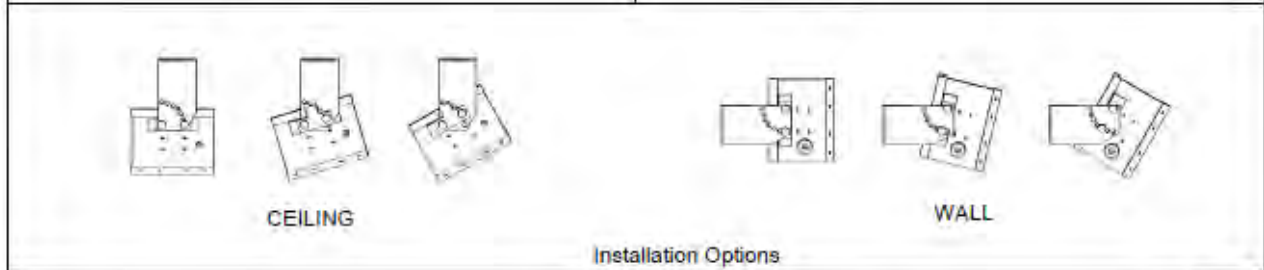
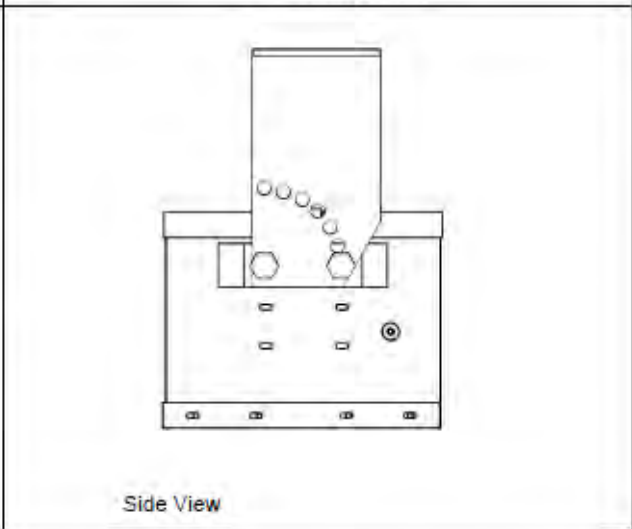
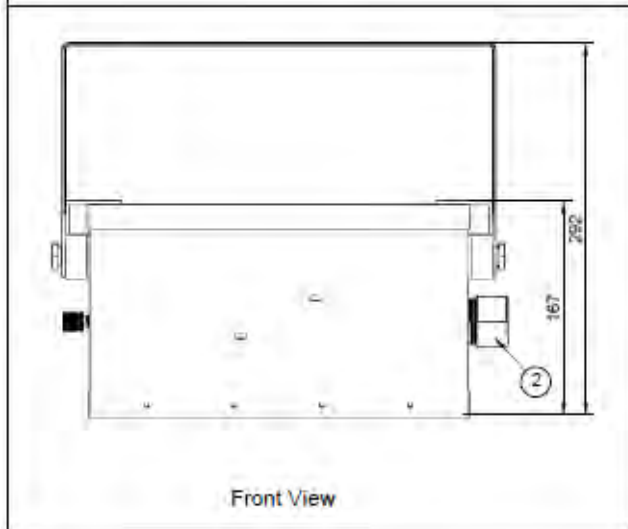
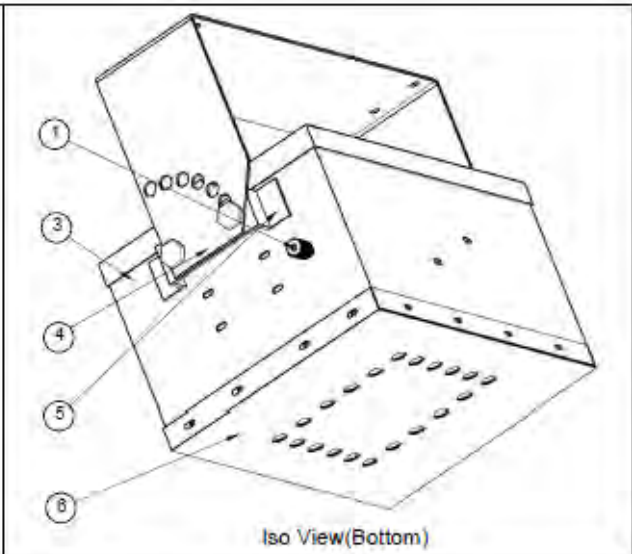
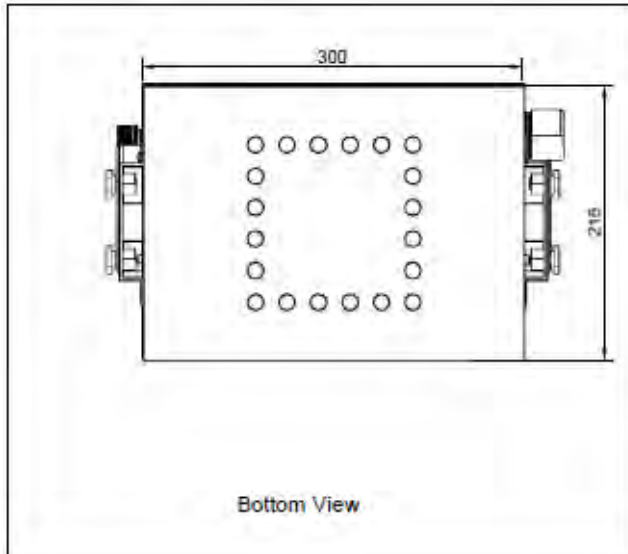

6	1	OUTLET	
5	1	BRACKET	
4	1	EXTERNAL HOUSING BRACKET SUPPORT	
3	1	HOUSING	
2	1	WIRES OUTLET JUNCTION BOX	
1	1	THERMOCONNECTOR	
Position	Quantity	Denomination	
PART LIST			

FirePro. Xtinguish FNX-1200
FNX-1200S

TITLE:
INSTALLATION DRAWING

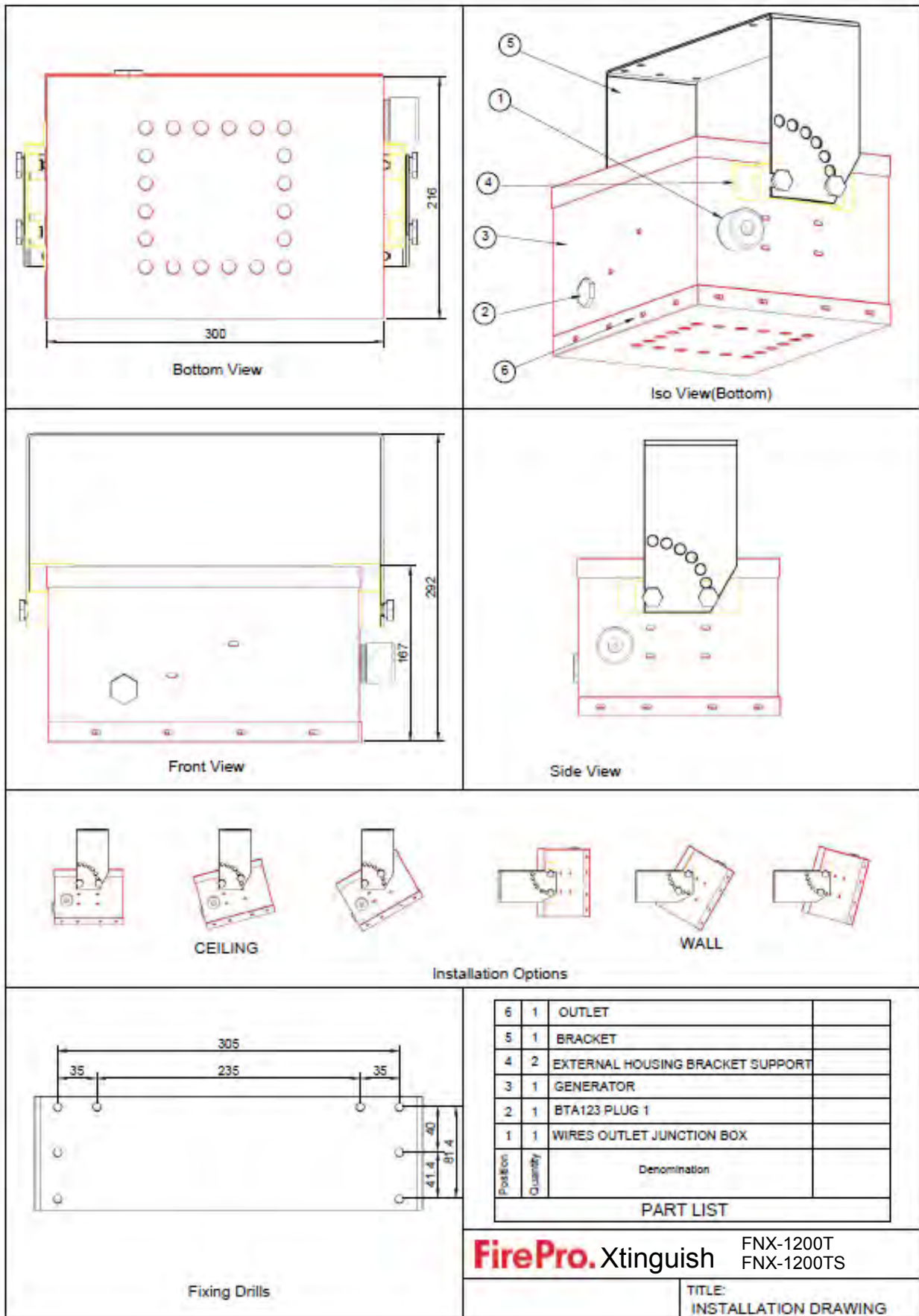

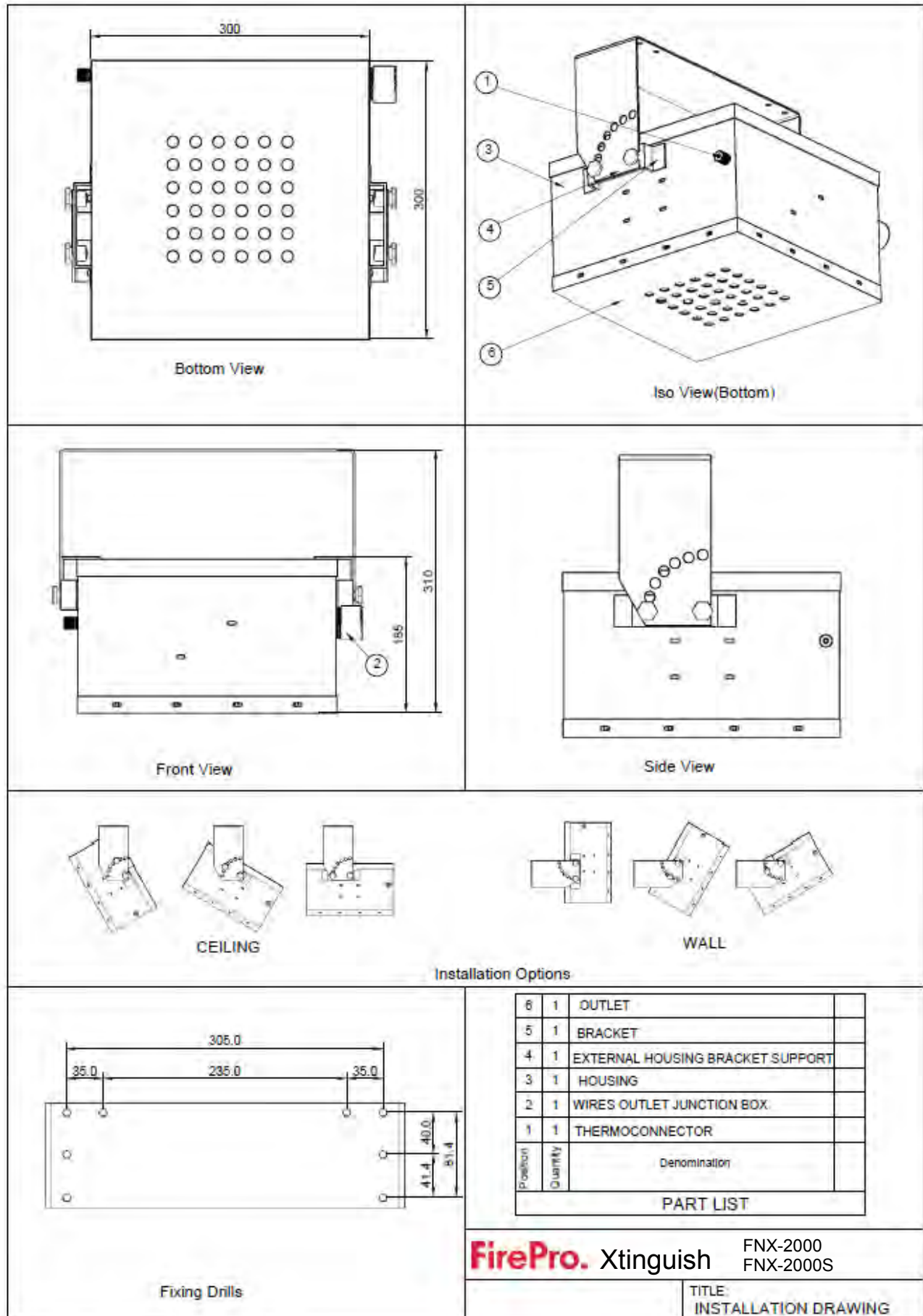

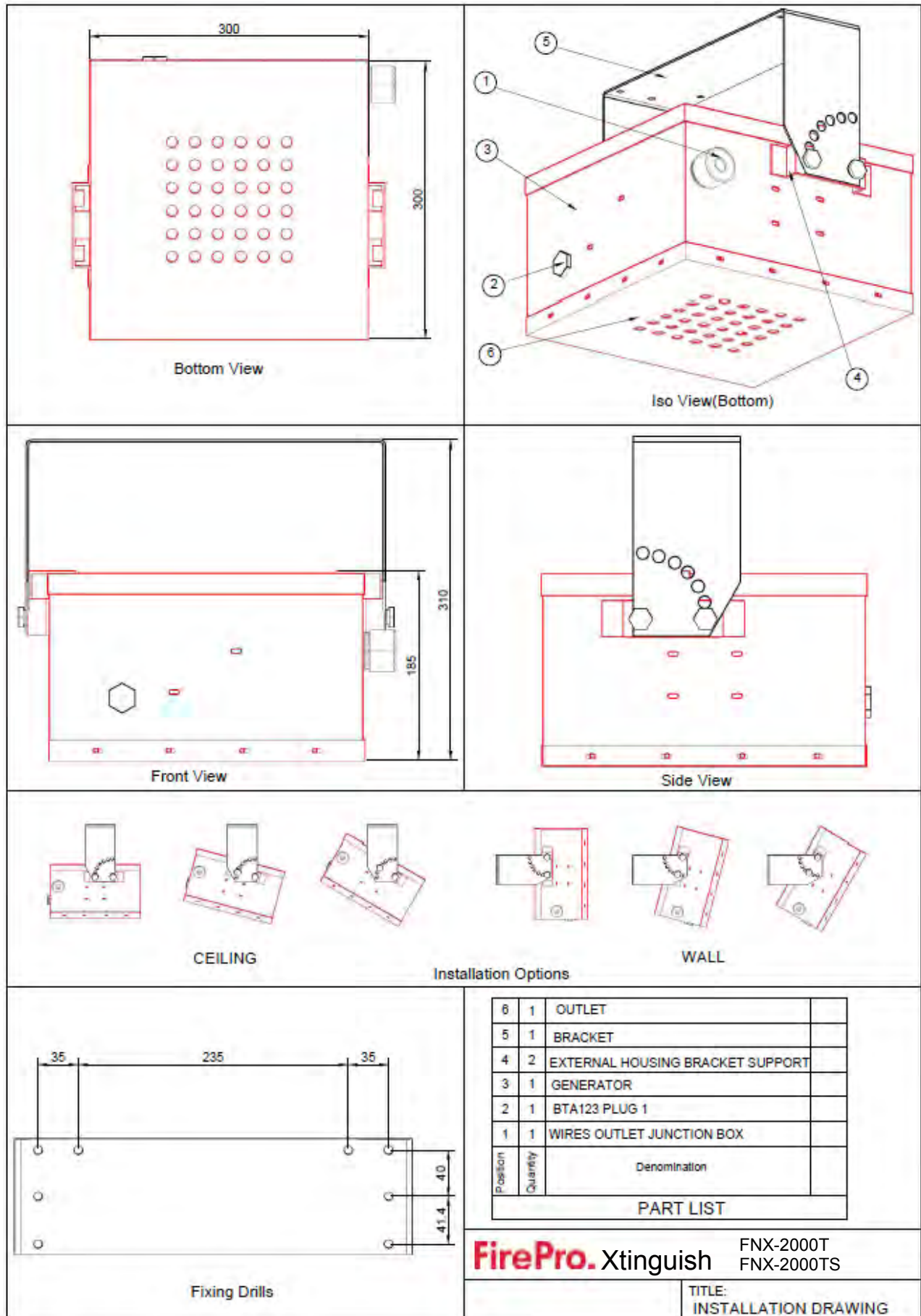

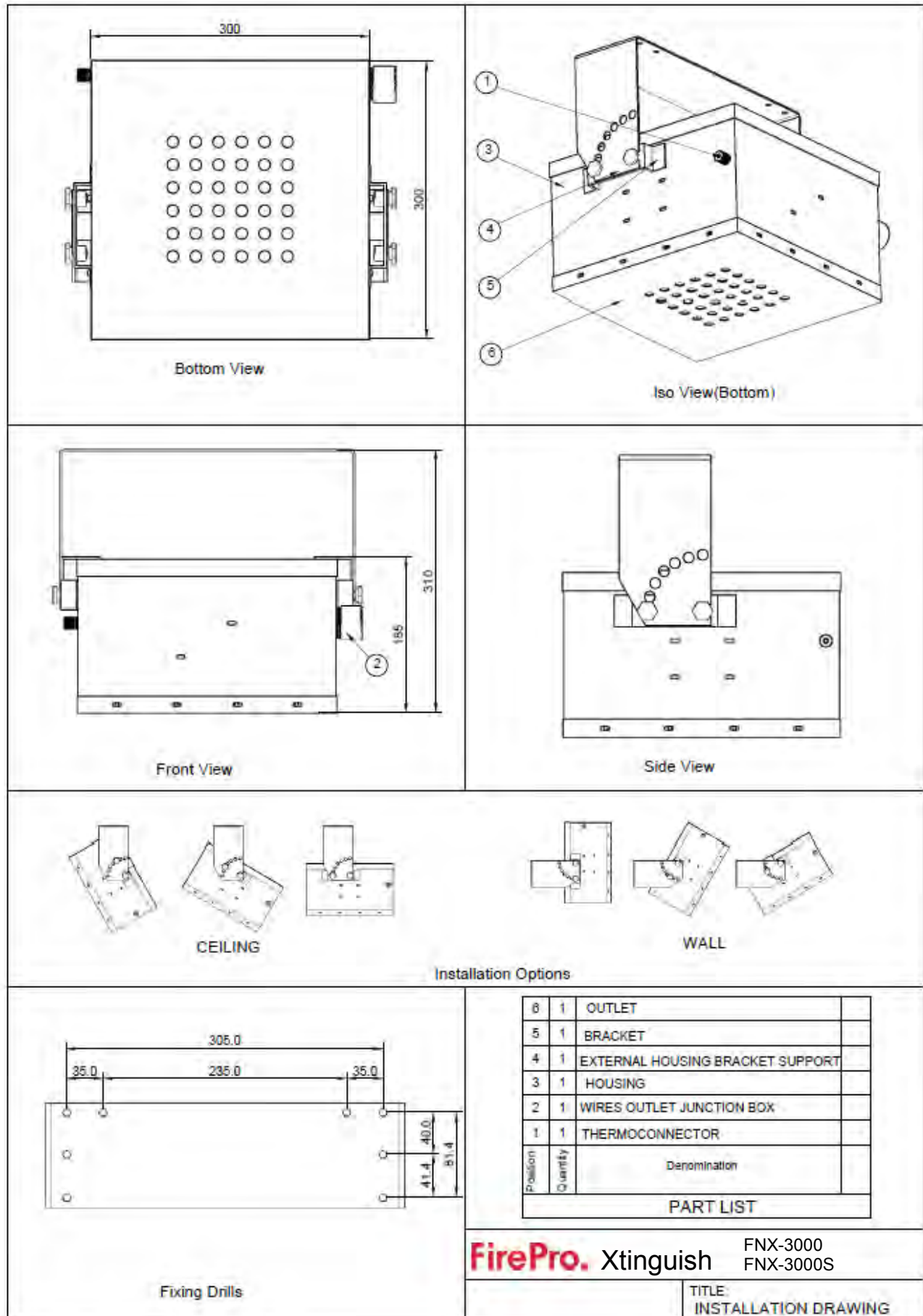

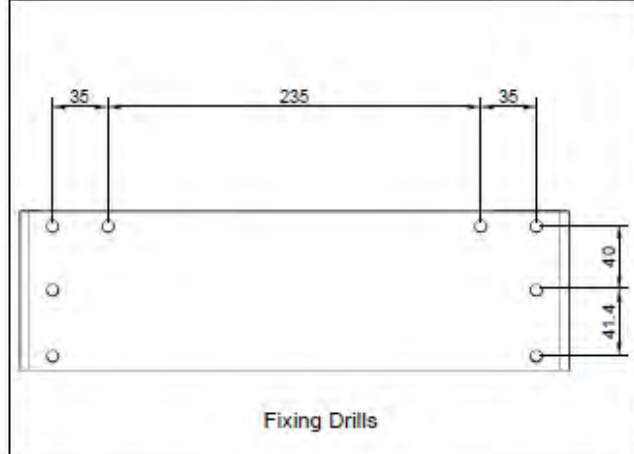
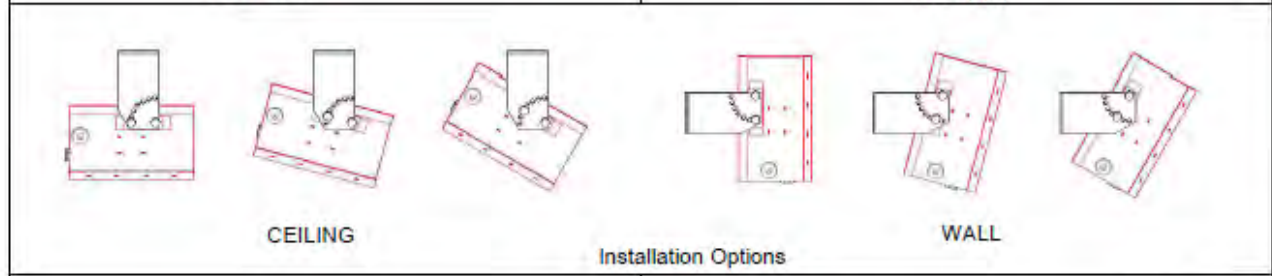
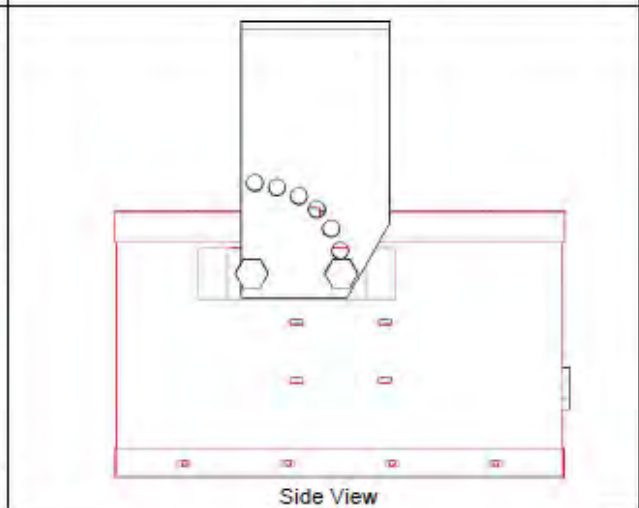
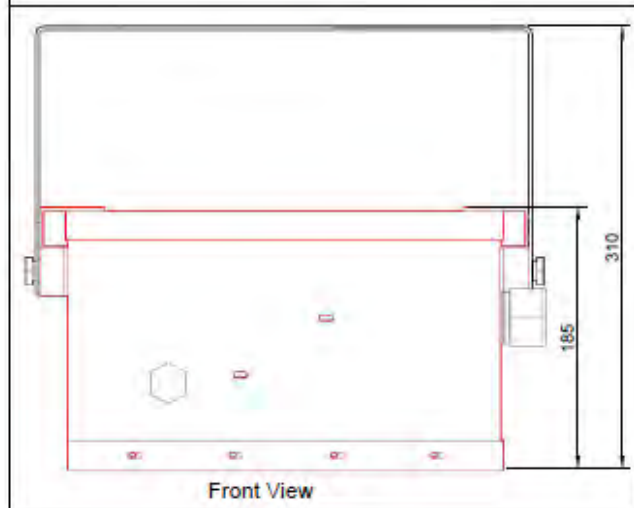
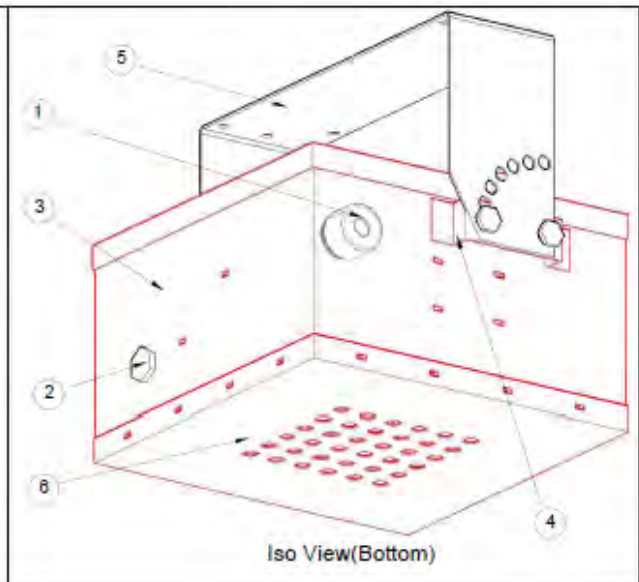
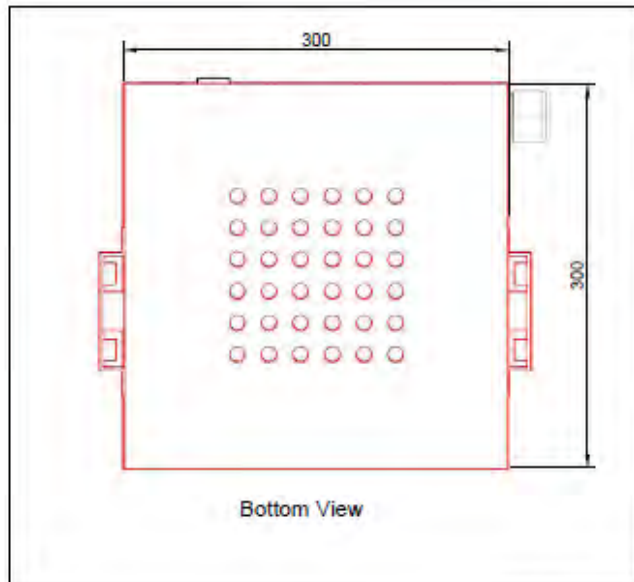

6	1	OUTLET	
5	1	BRACKET	
4	2	EXTERNAL HOUSING BRACKET SUPPORT	
3	1	GENERATOR	
2	1	BT123 PLUG 1	
1	1	WIRES OUTLET JUNCTION BOX	
Position	Quantity	Denomination	
PART LIST			

FirePro. Xtinguish FNX-3000T
FNX-3000TS

TITLE:
INSTALLATION DRAWING

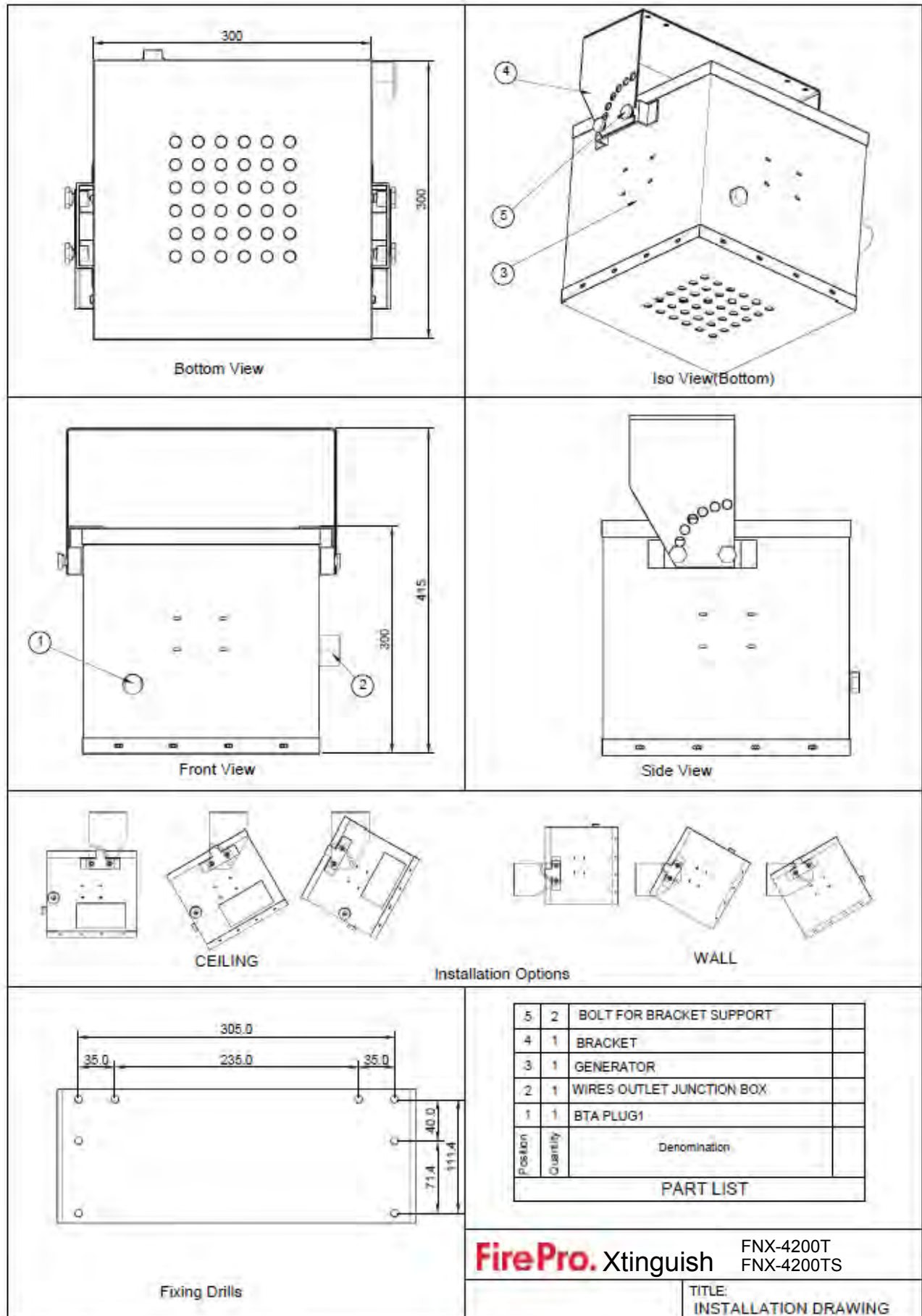

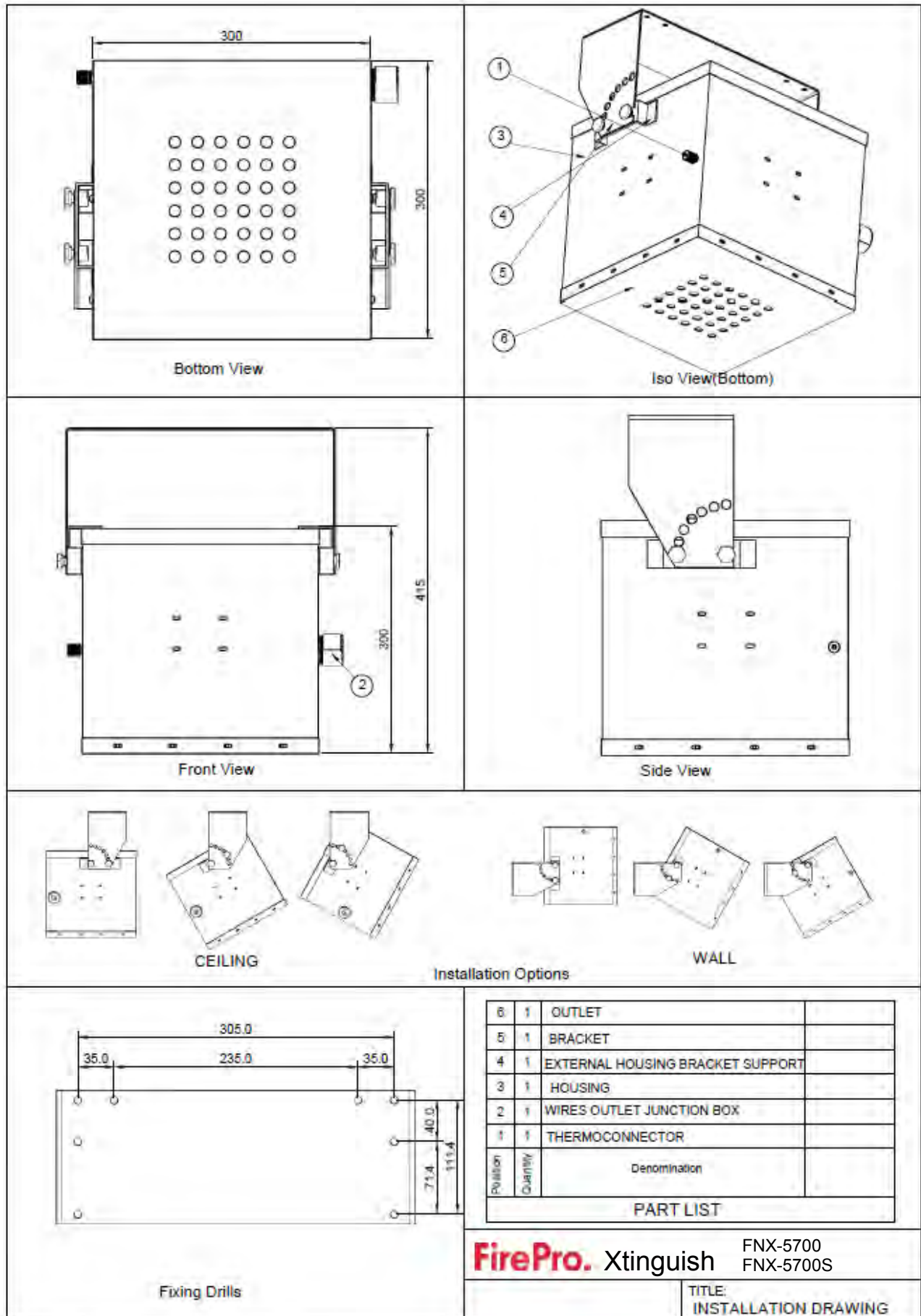

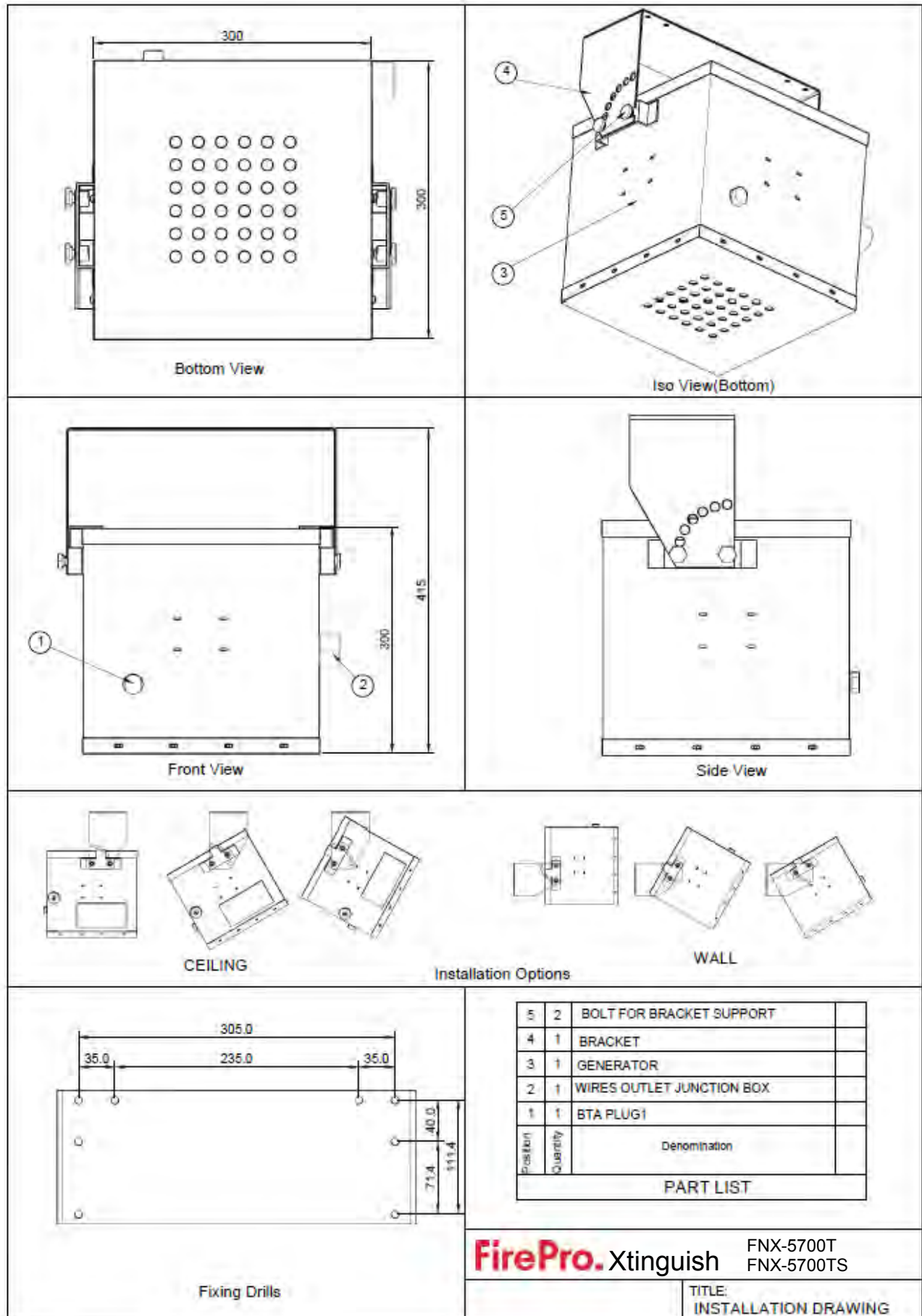

20 Appendix E – Referenced Publications

NFPA

National Fire Protection Association, 1 Batterymarch Park, Quincy, MA 02169-7471

- ▶ NFPA 2010 *Standard for Fixed Aerosol Fire Extinguishing Systems, 2015 Edition*
- ▶ NFPA 70 *National Electrical Code®*, 2005 Edition
- ▶ NFPA 72 *National Fire Alarm Code®*, 2010 Edition
- ▶ NFPA 2001 *Standard on Clean Agent Fire Extinguishing Systems, 2004 Edition*

ANSI

American National Standard Institute, Inc., 25 West 43rd Street, 4th Floor; New York, NY10036

- ▶ ANSI C2, National Electrical Safety Code, 2001

ISO

International Organization for Standardization, 1, Rue de Varembe, Case postale 56, CH-1211 Geneve 20, Switzerland

- ▶ ISO /IEC Guide 7, Requirements for Standards Suitable for Use for Conformity Assessment, 1994.

IMO

International Maritime Organization, 4 Albert Embankments, London, SE1 7SR, United Kingdom

- ▶ IMO MSC/Circ.1270, Guidelines for the Approval of Fixed Aerosol Fire-Extinguishing Systems Equivalent to Fixed Gas Fire-Extinguishing Systems, as Referred to in SOLAS 74, for Machinery Spaces; 2008 Edition

US Government

U.S. Government Printing Office, Washington, DC 20402

- ▶ Title 29, Code of Federal Regulations, Part 1910, Subpart S. Title 46, Code of Federal Regulations, Subchapter C, Parts 24-28.
- ▶ Title 46, Code of Federal Regulations, Subchapter J, "Electrical Engineering."
- ▶ Title 49, Code of Federal Regulations, Parts 171-190.
- ▶ Title 49, Code of Federal Regulations, Part 172.101, Subpart B.
- ▶ Title 49, Code of Federal Regulations, Part 173.34(e) (01). Title 49, Code of Federal Regulations, Parts 178.36 and 178.37.

Other References

- ▶ NFPA 10, *Standard for Portable Fire Extinguishers*, 2002 edition.
- ▶ NFPA 13, *Standard for the Installation of Sprinkler Systems*, 2002 edition.
- ▶ NFPA 51B, *Standard for Fire Prevention during Welding, Cutting, and Other Hot Work*, 2003 edition.
- ▶ NFPA 101®, *Life Safety Code®*, 2006 edition.
- ▶ NFPA 820, *Standard for Fire Protection in Wastewater Treatment and Collection Facilities*, 2003 edition.
- ▶ *Merriam-Webster's Collegiate Dictionary*, 11th edition, Merriam-Webster, Inc., Springfield, MA, 2003.

21 Appendix F – Definitions

Except where otherwise noted, the following definitions are taken from NFPA 2010, *Standard for Fixed Aerosol Fire-Extinguishing Systems*, 2010 Edition.

21.1 - Actuating mechanism.

A mechanism whose automatic or manual operation leads to the discharge of extinguishing agent.

21.2 - Agent Quantity.

Mass of solid aerosol-forming compound required to achieve the design application density within the protected volume within the specified discharge time.

21.3 - Approved.

Acceptable to the authority having jurisdiction.

21.4 - Authority Having Jurisdiction (AHJ).

An organization, office, or individual responsible for enforcing the requirements of a code or standard, or for approving equipment, materials, an installation, or a procedure.

21.5 - Automatic.

That which provides a function without the necessity of human intervention. [101, 2006]

21.6 - Automatic/manual switch.

Means of converting the system from automatic to manual actuation.

21.7 - Classification for Fires

Class A Fire.

Fires in ordinary combustible materials, such as wood, cloth, paper, rubber, and many plastics. [10, 2002]

Class B Fire.

Fires in flammable liquids, petroleum greases, tars, oil, oil-based paints, solvents, lacquers, alcohols, and flammable gases. [10, 2002]

Class C Fire.

Fires that involve energized electrical equipment. [10, 2002]

21.8 - Clearance.

Electrical Clearance.

The unobstructed air distance between extinguishing system equipment, including piping and nozzles, and unenclosed or un-insulated live electrical components not at ground potential.

Thermal Clearance.

The air distance between a condensed aerosol generator and any structure or components sensitive to the temperature developed by the generator.

21.9 - Condensed Aerosol.

An extinguishing medium consisting of finely divided solid particles, generally less than 10 microns in diameter, and gaseous matter, generated by a combustion process of a solid aerosol-forming compound.

21.10 - Coolant.

A heat-absorbing medium or process.

21.11 - Density.

Design Application Density (g/m^3). Extinguishing application density, including a safety factor, required for system design purposes.

21.12 - Discharge Port.

A passage such as nozzles or openings on an aerosol generator where aerosol is released when the generator is actuated.

21.13 - Disconnect Switch.

A manually operated switch, electrically supervised and secured from unauthorized use, that prevents the automatic or manual electrical activation of the aerosol generators during maintenance by electrically opening the releasing circuit.

21.14 - Extinguishing Application Density (g/m^3).

Minimum mass of a specific aerosol-forming compound per m^3 of enclosure volume required to extinguish fire involving particular fuel under defined experimental conditions excluding any safety factor.

21.15 - Generator.

A device for creating a fire-extinguishing medium by pyrotechnical means.

21.16 - Generator Casing.

The surface of the generator, excluding the surface containing the discharge ports.

21.17 - Hold Time.

Period of time during which an extinguishant is required to maintain an even distribution throughout the protected volume in an amount at least at the extinguishing application density.

21.18 - Hot work.

Work involving burning, welding, or similar operation that is capable of initiating fire or explosion. [51B, 2003]

21.19 - Inspection.

A visual examination of a system or portion thereof to verify that it appears to be in operating condition and free of physical damage. [820, 2003]

21.20 - Listed.

Equipment, materials, or services included in a list published by an organization that is acceptable to the authority having jurisdiction and concerned with evaluation of products or services, that maintains periodic inspection of production of listed equipment or materials or periodic evaluation of services, and whose listing states that either the equipment, material, or service meets appropriate designated standards or has been tested and found suitable for a specified purpose.

21.21 - Maintenance.

Work performed to ensure that equipment operates as directed by the manufacturer.

21.22 - Manual.

Requiring intentional intervention to accomplish a function.

21.23 - Normally Occupied.

An area or space where, under normal circumstances, persons are present.

21.24 - Normally Unoccupied.

An area or space not normally occupied by people but that can be entered occasionally for brief periods.

21.25 - Particulate Density.

The density of solid particulate in g/m^3 after discharge of the aerosol system at the design application density. This information is used to assess the degrees of visibility obscuration and the potential health effects of accidental exposure to the agent.

21.26 - Protected Volume.

Volume enclosed by the building elements around the protected enclosure, minus the volume of any permanent impermeable building elements within the enclosure.

21.27 - Release.

The physical discharge or emission of aerosol as a consequence of the condensed aerosol generator's actuation or operation of the dispersed aerosol agent container.

21.28 - Shall.

Indicates a mandatory requirement.

21.29 - Should.

Indicates a recommendation or that which is advised but not required.

21.30 - Solid Aerosol-Forming Compound.

A solid mixture of oxidant, combustible component and technical admixtures that produces a condensed aerosol upon actuation.

21.31 - Standard.

A document, the main text of which contains only mandatory provisions using the word "shall" to indicate requirements and which is in a form generally suitable for mandatory reference by another standard or code or for adoption into law. Non-mandatory provisions shall be located in an appendix or annex, footnote, or fine-print note and are not to be considered a part of the requirements of a standard.

21.32 - Supervisory Signal.

A signal indicating the need for action in connection with the supervision of guard tours, the fire suppression systems or the maintenance features of related systems. [72, 2002].

21.33 - Total Flooding Extinguishing System.

A system arranged to discharge an extinguishant into an enclosed space to achieve a uniform distribution of that extinguishant, at or above the design application density, throughout the space.

21.34 - Unoccupiable.

An area or space which cannot be occupied due to dimensional or other physical constraints.

The following definitions shall be applicable to marine aerosol extinguishing systems:

21.35 - A-60 Class Division.

A bulkhead or deck designed to resist the passage of smoke and flame for 1 hour, including limiting the temperature rise on the unexposed side to 180°C (325°F).

21.36 - Heat-Sensitive Material.

A material whose melting point is below 1700°F (926.7°C). [13, 2002]

21.37 - Marine System.

An aerosol system installed on a merchant vessel, ship, barge, boat, pleasure craft, offshore platform or other floating structure.

21.38 - Space.**Cargo Space.**

A space for the carriage or storage of items or products that are transported by the vessel.

Machinery Space.

A space protected by an aerosol system containing an internal combustion engine or mechanical equipment for handling, pumping, or transferring flammable or combustible liquids as a fuel to internal combustion engine.

21.39 - Vessel.**Inspected vessel.**

A vessel operated on the navigable waterways of the United States that is subject to the regulations in 46 CFR, which require it to be certificated and inspected as a passenger ship, cargo ship, oceanographic ship or a tank vessel.

Uninspected vessel.

A vessel operated on the navigable waterways of the United States that is subject to the regulations in 46 CFR Subchapter C, Parts 24 - 28, including pleasure craft, tugboats, towing vessels and certain fishing vessels.



ویدیو - انیمیشن های اطفاء، اعلام حریق، تهویه و تخلیه دود (رایگان)

برای مشاهده هر یک از ویدیوهای زیر کافیست بر روی عنوان آن آموزش کلیک نمایید تا به صفحه ویدیو و آموزش آن عنوان هدایت شوید.

انیمیشن ویدیو

- [اطفای حریق آبی](#)
 - [سیستم اطفای لوله خشک اسپرینکلر](#)
 - [سیستم اطفای لوله تر اسپرینکلر](#)
 - [سیستم اطفای پیش عملگر](#)
 - [سیستم اطفای واترمیس](#)
 - [سیستم اطفای سیلابی](#)
- [سیستم اطفای فوم](#)
- [تجهیزات اطفای حریق - تجهیزات هشدار دهنده](#)
- [تجهیزات اطفای حریق - اسپرینکلر](#)
- [سیستم اطفای آشپزخانه صنعتی](#)
- [سیستم اطفای آبروسل](#)
- [سیستم اطفای دستی](#)
- [سیستم اطفای گازی](#)
 - [سیستم اطفای FM200 , NOVEC, Inert Gas \(IG\)](#)
 - [سیستم اطفای CO₂](#)
- [سیستم تهویه و تخلیه دود](#)
- [سیستم اعلام حریق](#)
 - آدرس پذیر
 - متعارف

آموزش استاندارد

- [آموزش استاندارد NFPA 13](#)
- [آموزش استاندارد NFPA 14](#)
- [آموزش استاندارد NFPA 20](#)





آموزش نرم افزار

- اتواسپرینک
- پایروسیم
- پث فایندر

دانلود استاندارد

- ترجمه استاندارد NFPA 30,14,13,10
- تمامی استانداردهای NFPA & FM
- ترجمه استاندارد NFPA 1037

محصولات

- اتواسپرینک ۲۰۱۳ و ۲۰۱۹ به زبان فارسی برای اولین بار در ایران
- آلام کد ۲۰۱۹ به زبان فارسی برای اولین بار در ایران
- اطفای حریق آبی
- پایپنت (ماژول اسپرینکلر)
- کانتم

دوره های حضوری

- آموزش اتواسپرینک
- آموزش آلام کد
- آموزش پایروسیم
- آموزش کانتم + اگزاست
- آموزش اطفای آبی + پمپ + بازدید از کارگاه
- آموزش اطفای گازی
- آموزش اطفای فوم
- آموزش مبحث سوم مقررات ملی
- آموزش اعلام حریق F&G
- آموزش اعلام حریق آدرس پذیر
- آموزش اعلام حریق متعارف
- دوره آمادگی آزمون آتش نشانی (برق، مکانیک، عمران، معماری)





آموزشگاه ادوفایر
EDUFIRE

All **NFPA** & **FM** STANDARDS

 **EDUFIRE_NFPA**

 **EDUFIRE.IR**

 Latest Version

FREE

  
EDUFIRE.IR

۰۲۱-۷۷۶۸۶۹۶۶ - ۰۹۳۵۱۲۵۳۳۶۶

WWW.EDUFIRE.IR



Telegram: **EDUFIRE_IR**

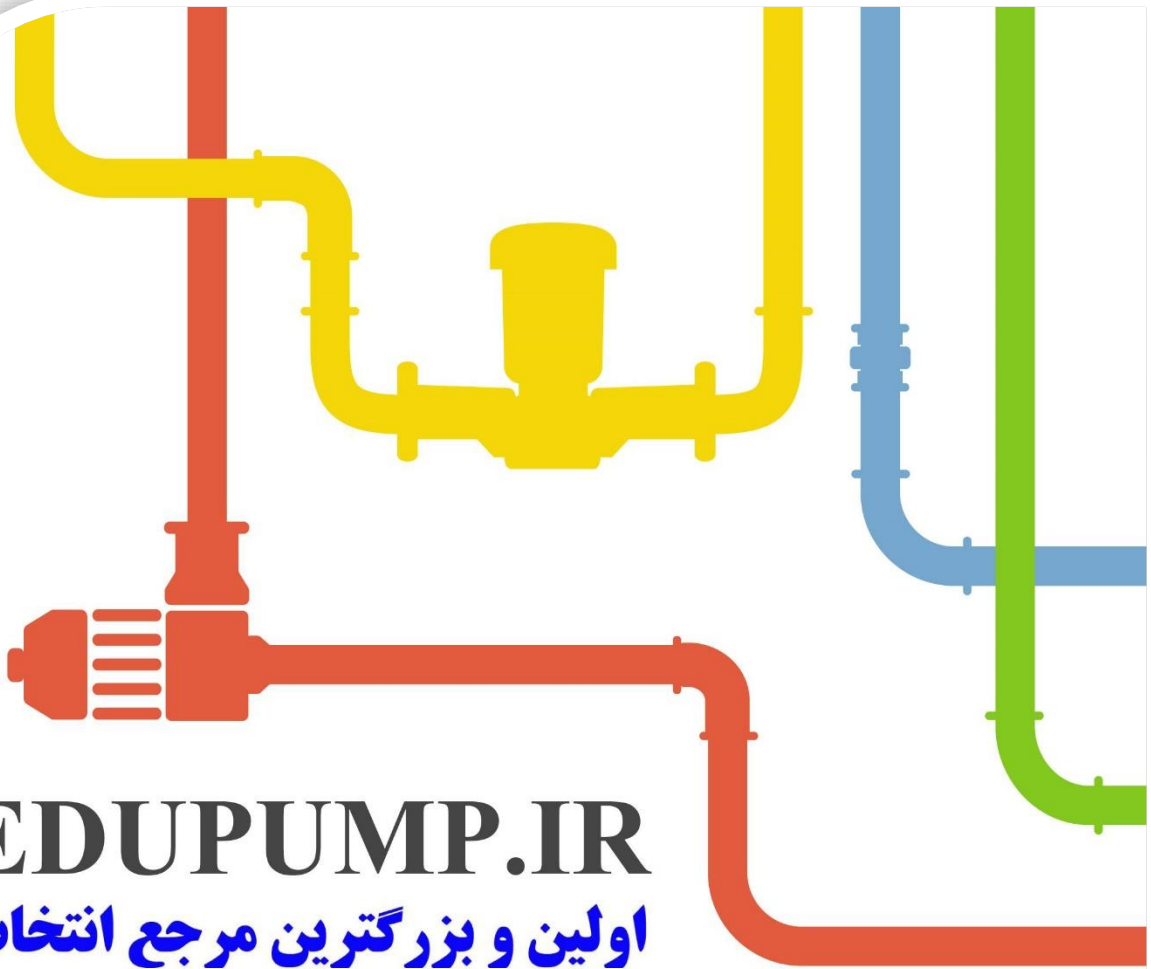

EDUPUMP.IR

اولین و بزرگترین مرجع انتخاب آنلاین سیستم‌های پمپاژ در ایران

انتخاب آنلاین انواع الکتروپمپ :

- الکتروپمپ اطفاء حریق در ۳ کلاس تصرف S۱ - S۲ - S۳
- الکتروپمپ زمینی
- الکتروپمپ طبقاتی عمودی
- الکتروپمپ طبقاتی افقی
- الکتروپمپ خطی
- الکتروپمپ کفکش
- الکتروپمپ لیجنش
- الکتروپمپ شناور
- الکتروپمپ استخری

انتخاب آنلاین بوسترپمپ :

- بر اساس نوع فضای کاربری
- بر اساس اطلاعات بوسترپمپ

ارائه مقالات و مطالب آموزشی
سیستم آب و فاضلاب



ارائه مقالات و مطالب آموزشی
سیستم اطفاء حریق و مهندسی ایمنی

دانلود کاتالوگ تفکیک شده
به ازای هر الکتروپمپ



مشاهده اطلاعات مربوط
به هر الکتروپمپ





پیشگامان صنعت و ایمنی پرگاس

PISHGAMAN SANAAT & IMENI PERGAS



طراح، مشاور و مجری سیستم‌های ایمنی و تاسیساتی
دارای صلاحیت سازمان آتش‌نشانی تهران
اخذ تاییدیه آتش‌نشانی

برای اطلاعات بیشتر اسکن کنید



تهران . خیابان سعدی شمالی . خیابان

شهید همدانی نور . پلاک ۳۱ . واحد ۱



WWW.PERGAS-CO.IR

INFO@PERGAS-CO.IR

۷۷۶۸۶۹۶۶

۷۷۶۷۸۶۵۹



۰۲۱-۷۷۶۸۶۹۶۶ - ۰۹۳۵۱۲۵۳۳۶۶

WWW.EDUFIRE.IR



Telegram: EDUFIRE_IR